

FOREWORD

This manual has been prepared to help inspection and service works involving electric wiring of the following model be done efficiently.

Applicable model :
GROUP 1 SQ416V, SQ420V, SQ420W, SQ625W
GROUP 2 SQ416Q, SQ420Q

When servicing the applicable model of GROUP 1, consult GROUP 1; as for the applicable model of GROUP 2, consult GROUP 2 first, and then GROUP 1 for any description not found in GROUP 2.

In order to make a good use of this manual, it is important to have a full understanding of its first section "HOW TO USE THIS MANUAL".

All the data and information contained in this manual are based on the vehicle of certain specifications. Therefore, please note that the actual vehicle being serviced may vary somewhat because of differences in specifications or statutory regulations.

Also note that since this manual has been prepared based on the vehicles of 1998 November production, the description in it may vary from vehicles of later production if vehicle specifications have been modified.

For inspection and service works of electrical parts, following reference materials are also available for your help.

- RELATED SERVICE MANUAL (S/M)**
 ·SQ416/420/625(S/M) 99500-65D00
 ·SQ416/420/625(S/M S)..... 99501-65D10

SUZUKI MOTOR CORPORATION
OVERSEAS SERVICE DEPARTMENT

TABLE OF CONTENTS

SECTION

GROUP 1

HOW TO USE THIS MANUAL

8A-1

INSTALLATION POSITIONS OF SINGLE UNIT PARTS

8A-4

GROUND POINT

8A-5

POWER SUPPLY DIAGRAM

8A-6

SYSTEM CIRCUIT DIAGRAM

8A-7

GROUP 2

**SUPPLEMENT FOR CANVAS TOP MODEL:
 SQ416Q, SQ420Q**

GROUP 1
GRUPPE 1
GROUPE 1
GRUPO 1

SQ416 / SQ420 /
SQ625

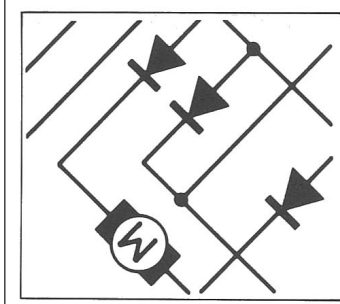

WIRING DIAGRAM MANUAL
HANDBUCH FÜR VERKABELUNG
MANUEL DES SCHEMAS DE CABLAGE
MANUAL DE DIAGRAMA DE CONEXIONES

SECTION 8A-1

HOW TO USE THIS MANUAL

8A-1

CONTENTS

· Manual Contents and Description	8A-1- 2
· Applicability	8A-1- 2
· Cautions in Servicing	8A-1- 3
· Symbols and Marks	8A-1- 6
· Abbreviations	8A-1- 7
· Wire Color Symbols	8A-1- 7
· How to Read Power Supply Diagram (SECTION 8A-6)	8A-1- 8
· How to Read Installation Positions of Single Unit Parts (SECTION 8A-4).....	8A-1- 9
· How to Read Ground Point (SECTION 8A-5)	8A-1-10
· How to Read System Circrit Diagram (SECTION 8A-7)	8A-1-12
· Indication of Connectors and How to Read them	8A-1-14

MANUAL CONTENTS AND DESCRIPTION

This manual consists of diagrams showing the wiring.

SECTION		DESCRIPTION
Installation Positions of Single Unit Parts	8A-4	Positions where each fuse, relay and control unit are installed in this vehicle are shown.
Ground Point	8A-5	Points on the body where grounding is made are shown.
Power Supply Diagram	8A-6	Electric flow passage from the positive terminal of the battery to the main fuse and each fuse in the fuse box are shown and names of main systems that apply a load to each fuse are indicated.
System Circuit Diagram	8A-7	System circuit diagrams are arranged side by side to show how the electric circuits of the whole vehicle are connected.

APPLICABILITY

This manual is applicable to the vehicles listed below.

NOTE :

Bear in mind that description in the text may vary from the actual vehicle depending on specifications.

SQ416V (X) JSAFTA03V00100001(X)~
 (X) JSAFTA03VW4100001(X)~
 (X) JSAFTA03VW0100001(X)~
 JS3TA03V ☐ X4100001~

SQ420V (X) JSAFTA52V00100001(X)~
 (X) JSAFTA52VW4100001(X)~
 (X) JSAFTA52VW0100001(X)~
 JS3TA52V ☐ X4100001~

SQ420W (X) JSAFTL52V00100001(X)~
 (X) JSAFTL52VW4100001(X)~
 (X) JSAFTL52VW0100001(X)~
 JS3TL52V ☐ X4100001~

SQ625W (X) JSAFTD62V00100001(X)~
 (X) JSAFTD62VW4100001(X)~
 (X) JSAFTD62VW0100001(X)~
 JS3TD62V ☐ X4100001~

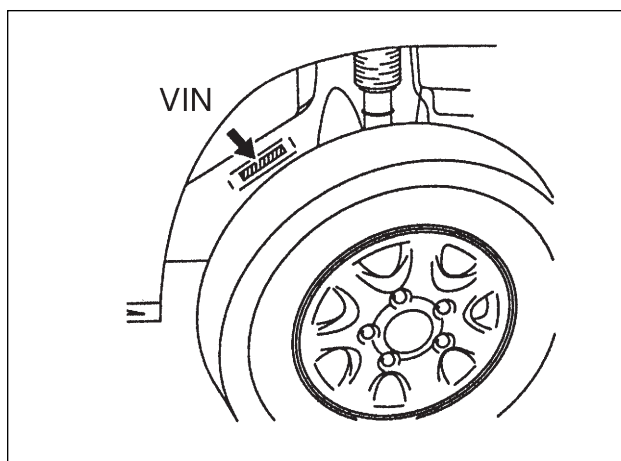

Vehicle Identification Number Location

CAUTIONS IN SERVICING

When performing works related to electric systems, observe following cautions for the purpose of protection of electrical parts and prevention of a fire from occurrence.

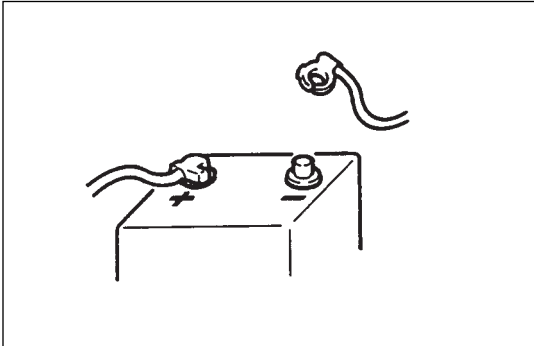

- When removing the battery from the vehicle or disconnecting the cable from the battery terminals for inspection or service works on the electric systems, always confirm first that the ignition switch and all the other switches have been turned OFF. Otherwise, the semiconductor part may be damaged.
- When disconnecting cables from the battery, be sure to disconnect the one from the negative (-) terminal first and then the other from the positive (+) terminal.
- Reverse the above order when connecting the cables to the battery terminals.

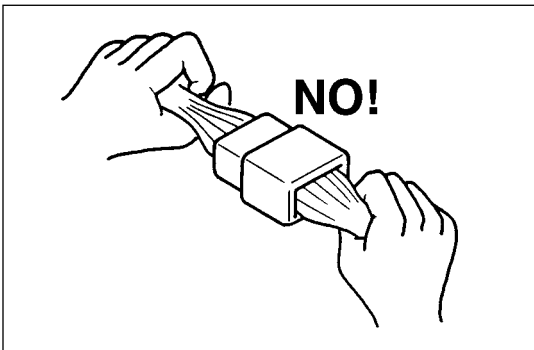

- When disconnecting connectors, never pull the wiring harnesses. Unlock the connector lock first and then pull them apart by holding connectors themselves.

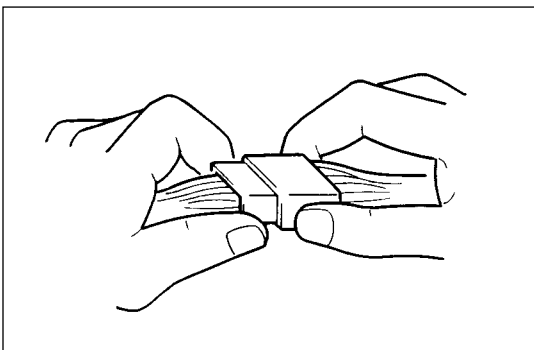

- When connecting connectors, also hold connectors and push them together until they lock securely (a click is heard).

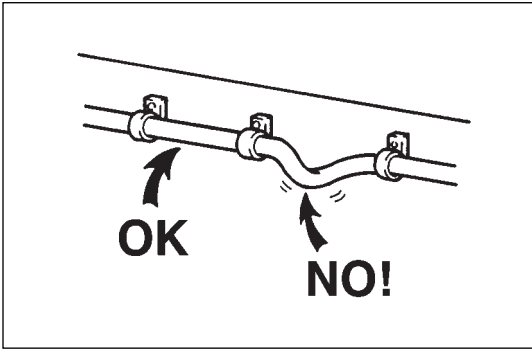

- When installing the wiring harness, fix it with clamps so that no slack is left.

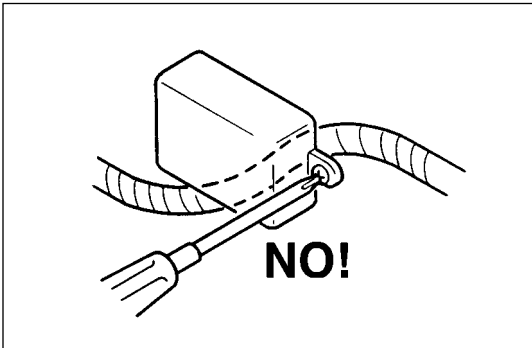

- When installing vehicle parts, be careful so that the wiring harness is not interfered with or caught by any other part.

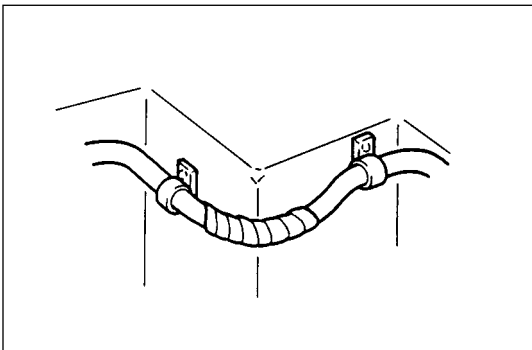

- To avoid damage to the harness, protect its part which may contact against a part forming a sharp angle by winding tape or the like around it.

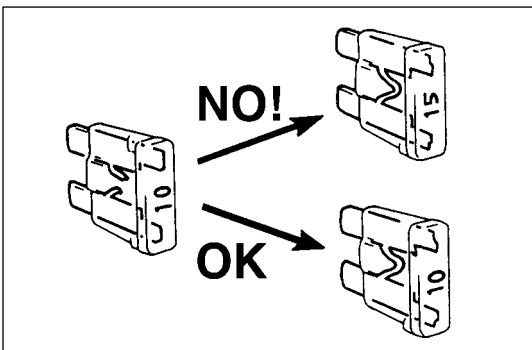

- When replacing a fuse, make sure to use a fuse of the specified capacity. Use of a fuse with a larger capacity will cause a damage to the electrical parts and a fire.

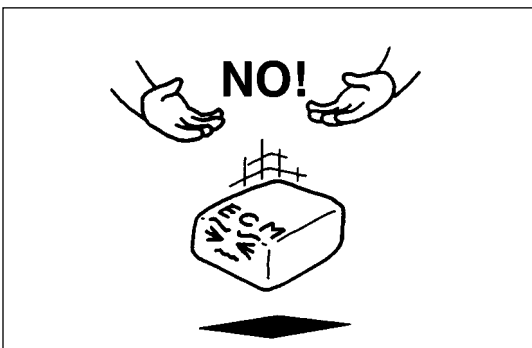

- Always be careful not to handle electrical parts (computer, relay, etc.) in a rough manner or drop them.

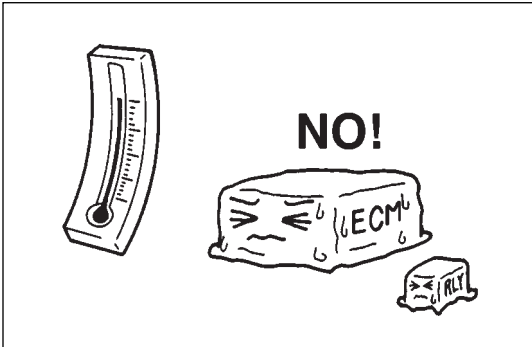

- When performing a work that produces a heat exceeding 80°C in the vicinity of the electrical parts, remove the heat sensitive electrical part(s) beforehand.

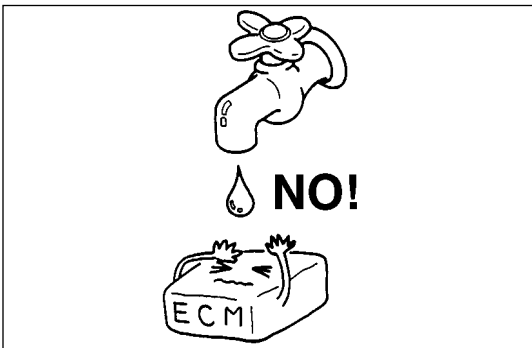

- Use care not to expose connectors and electrical parts to water which will be a cause of a trouble.

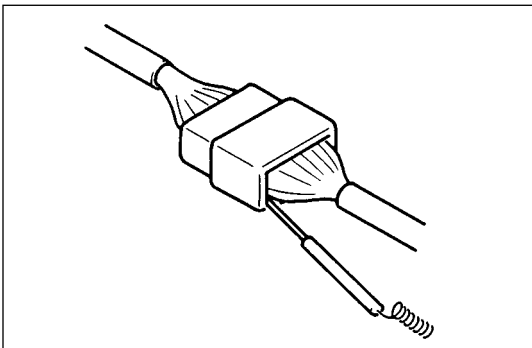

- When using a tester for checking continuity or measuring voltage, be sure to insert the tester probe from the wire harness side.

WARNING:

This vehicle is equipped with Supplemental Inflatable Restraint Air Bag System. Service on or around Air Bag System Components or Wiring must be performed only by an authorized Suzuki dealer. Please observe all the warnings described in "On Vehicle Service section", the Air Bag System Component and Wiring Location View in the service manual mentioned in FOREWORD of this manual before performing service on or around Air Bag System Components or Wiring. Failure to follow WARNING could result in unintended air bag deployment or could render the air bag inoperative. Either of these two conditions may result in severe injury.

SYMBOLS AND MARKS

In the diagrams of this manual, each equipments are represented by the symbols and marks as shown below.

Battery	Ground		Fuse	Main fuse
Circuit breaker	Coil, Solenoid	Heater	Bulb	
Cigarette lighter	Motor	Pump	Horn	Speaker
Buzzer	Chime	Condenser	Thermistor	Reed switch
Resistance	Variable resistance		Transistor	
Photo transistor	Diode	Reference (zener) diode	Light emitting diode	Photo diode
Piezoelectric element	Harness		Relay	
Connector	Switch		"O" Type terminal	Joint connector

ABBREVIATIONS

Listed below are the abbreviations as used in this manual and their full terms.

Abbreviation	Full term	Abbreviation	Full term
2WD	2 wheel drive vehicles	IAT	Intake air temperature
4WD	4 wheel drive vehicles	MAP	Manifold absolute pressure
A/C	Air conditioning	LH(D)	Left hand (drive vehicle)
A/T	Automatic transmission	LO	Low
ACC	Accessory	M/T	Manual transmission
COMB	COMBINATION	P/N	Power/Normal
DRL	Daytime running light (If equipped)	RH(D)	Right hand (drive vehicle)
EGR	Exhaust gas recirculation	ST	Starter
HI	High	VSV	Vacuum switching valve
IG	Ignition	ECM	Engine control module
ILL	Illumination	PCM	Power train control module
IND	Indicator	SDM	Sensing and diagnostic module
CKP	Crank shaft position	ICM	Immobilizer control module
ECT	Engine coolant temperature	J/C	Joint connector
IAC	Idle air control	1.6L	1.6 liter model
2.5L	2.5 liter model	2.0L	2.0 liter model

Symbol	Wire Core	Symbol	Wire Core
B	Black	Or	Orange
Bl	Blue	R	Red
Br	Brown	W	White
G	Green	Y	Yellow
Gr	Gray	P	Pink
Lbl	Light Blue	V	Violet
Lg	Light Green		

WIRE COLOR SYMBOLS

The initial alphabet(s) of the color name is used to represent each color as listed at the left.

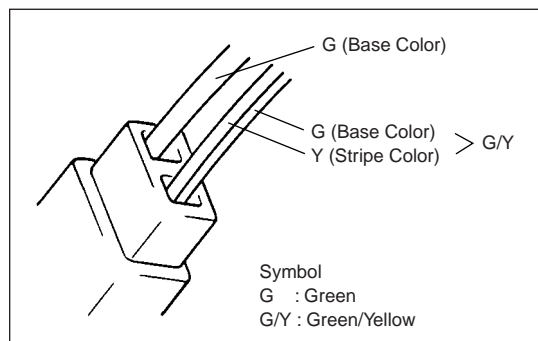

There are two types of wire color : one-color type and 2-color type(with a stripe). In case of 2-color type, the first alphabet ("G" of the example in the figure at the left) represents the basic color(color of wire insulation) and the next alphabet ("Y" of the example) represents the color of stripe.

HOW TO READ POWER SUPPLY DIAGRAM

"POWER SUPPLY DIAGRAM" section shows the circuit from the positive terminal of the battery to each fuse in the fuse box and where each fuse is connected (each system circuit name). In addition, the electric load value of each fuse is indicated.

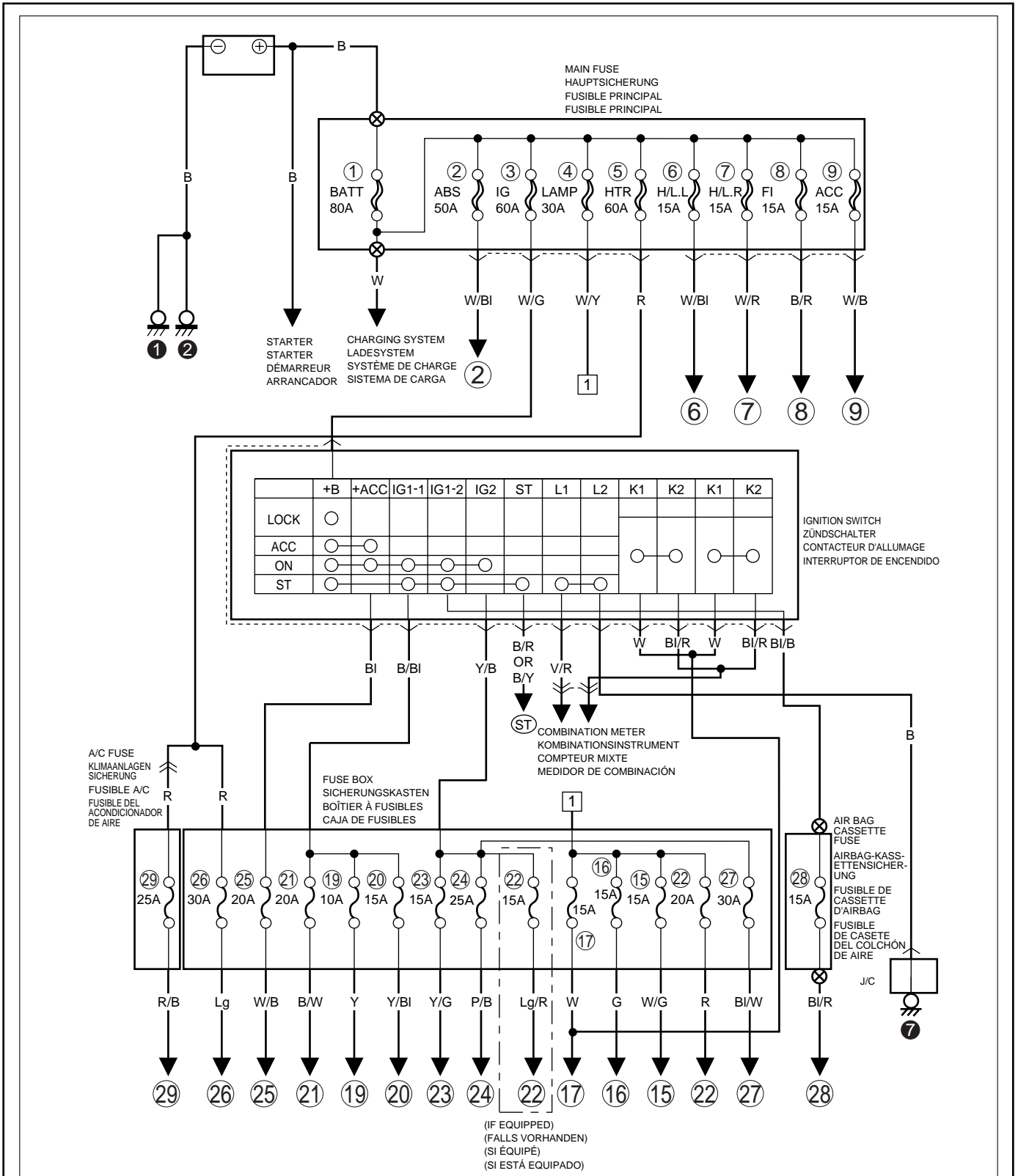

NOTE :
 ⊗ indicates main fuses and ⊘ indicates fuses in the fuse box or cassette fuse.

HOW TO READ INSTALLATION POSITIONS OF SINGLE UNIT PARTS

The diagram in "INSTALLATION POSITIONS OF SINGLE UNIT PARTS" section shows installation positions of fuse, relays and control units used in this vehicle. They are illustrated as shown below.

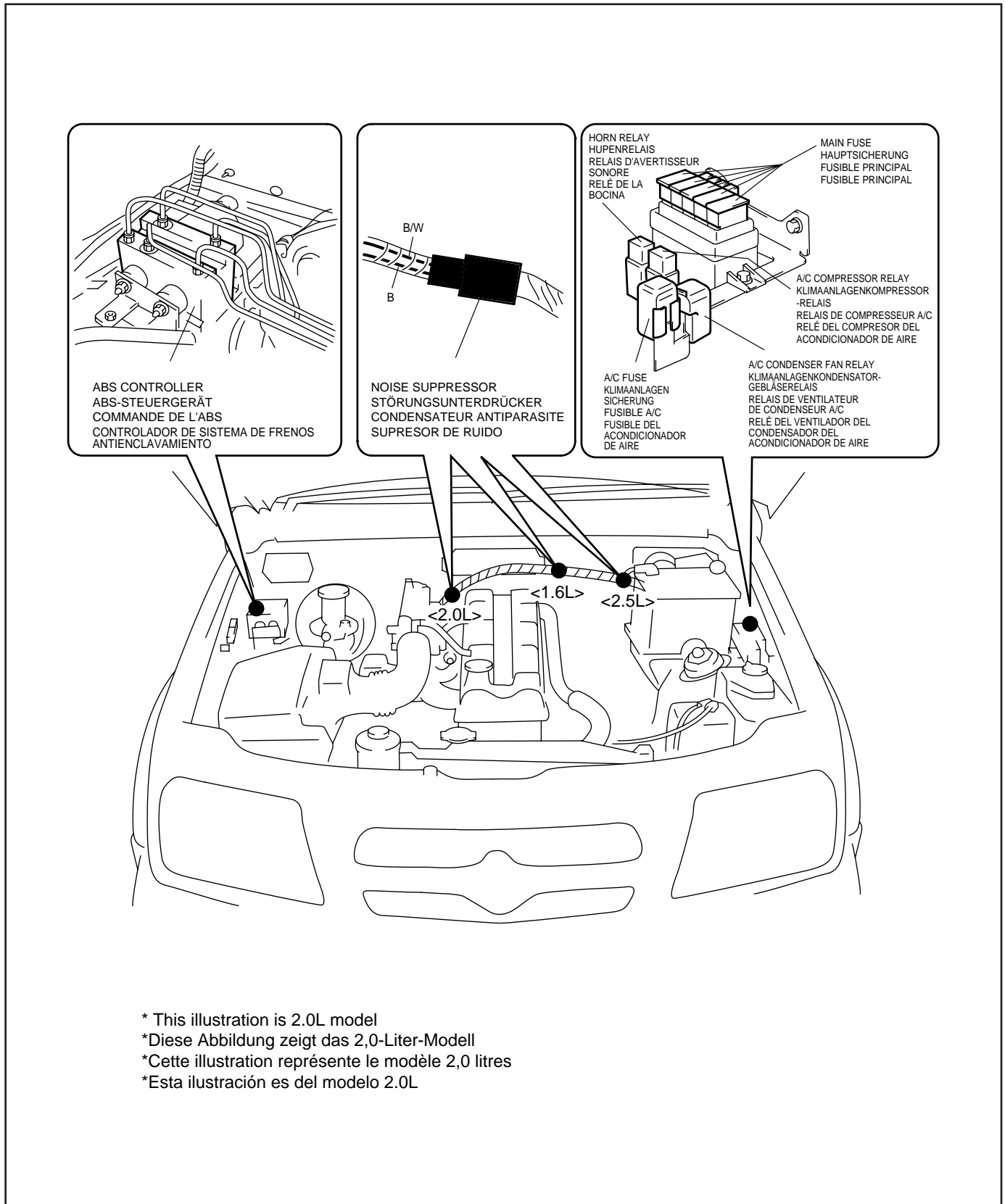

* This illustration is 2.0L model
 *Diese Abbildung zeigt das 2,0-Liter-Modell
 *Cette illustration représente le modèle 2,0 litres
 *Esta ilustración es del modelo 2.0L

HOW TO READ GROUND POINT

Ground point means the position where the negative harness among wiring harnesses is grounded. The diagram in "GROUND POINT" section shows such ground points. In "SYSTEM CIRCUIT DIAGRAM" section, there are many ground marks followed by black circles with numerical figures in them (⑩) which mean that the end of the harness with such black circle is grounded to some part of the vehicle.

"SYSTEM CIRCUIT DIAGRAM" section

■ WINDSHIELD WIPER & WASHER

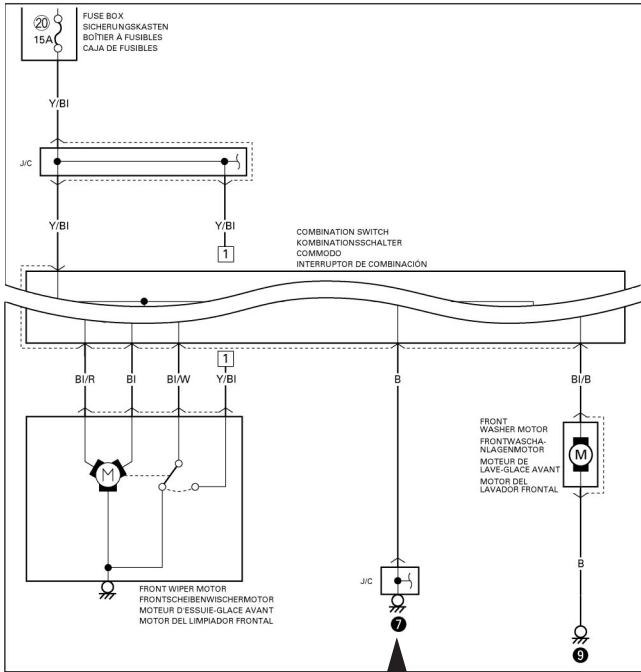

[How to locate ground point]

Look in "GROUND POINT" section for the black circle with the same numerical figure (⑩) as the desired one in "SYSTEM CIRCUIT DIAGRAM" section.

NOTE :

If there is an electrical part whose ground point is not found in "GROUND POINT" section, that part itself serves as a ground.

"GROUND POINT" section

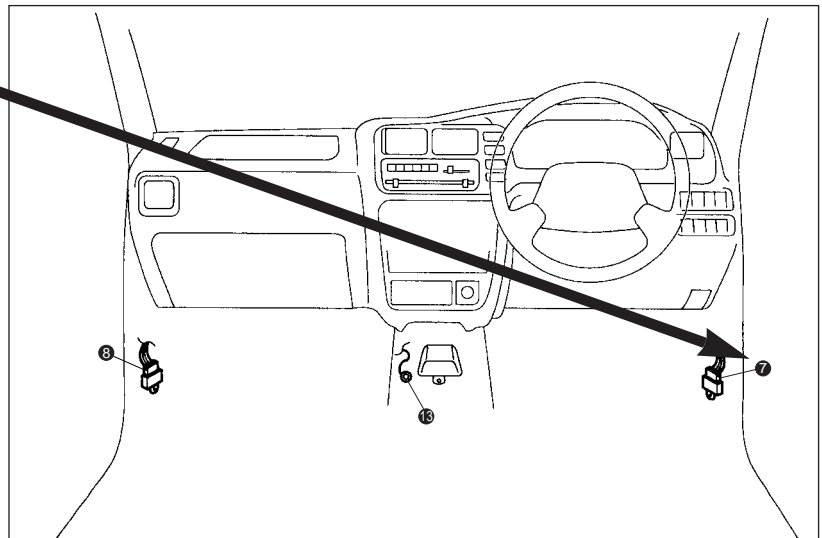

NOTE: The illustration is for RHD. LHD view is symmetrical;

⑦ is at the driver side and ⑨ is at the passenger side.

HINWEIS: Die Abbildung für die Sicht für Fahrzeug mit Links- und Rechtslenkung ist symmetrisch;

⑦ ist auf der Fahrerseite und ⑨ ist auf der Beifahrerseite.

REMARQUE: L'illustration représente le modèle à conduite à droite. La représentation du modèle à conduite à gauche est symétriquement opposée; ⑦ est sur le côté conducteur et ⑨ sur le côté passager.

NOTA: La ilustración es para el modelo con dirección a la derecha. La vista para el modelo con dirección a la izquierda es simétrica; ⑦ está en el lado del conductor y ⑨ está en el lado del pasajero.

MEMO

HOW TO READ SYSTEM CIRCUIT DIAGRAM

The circuit diagram of each system shows the electric circuit from the main fuse , fuse box or the ignition switch (at the top in the diagram) to the ground (at the bottom) so that the circuit can be followed easily when performing inspection and service work.

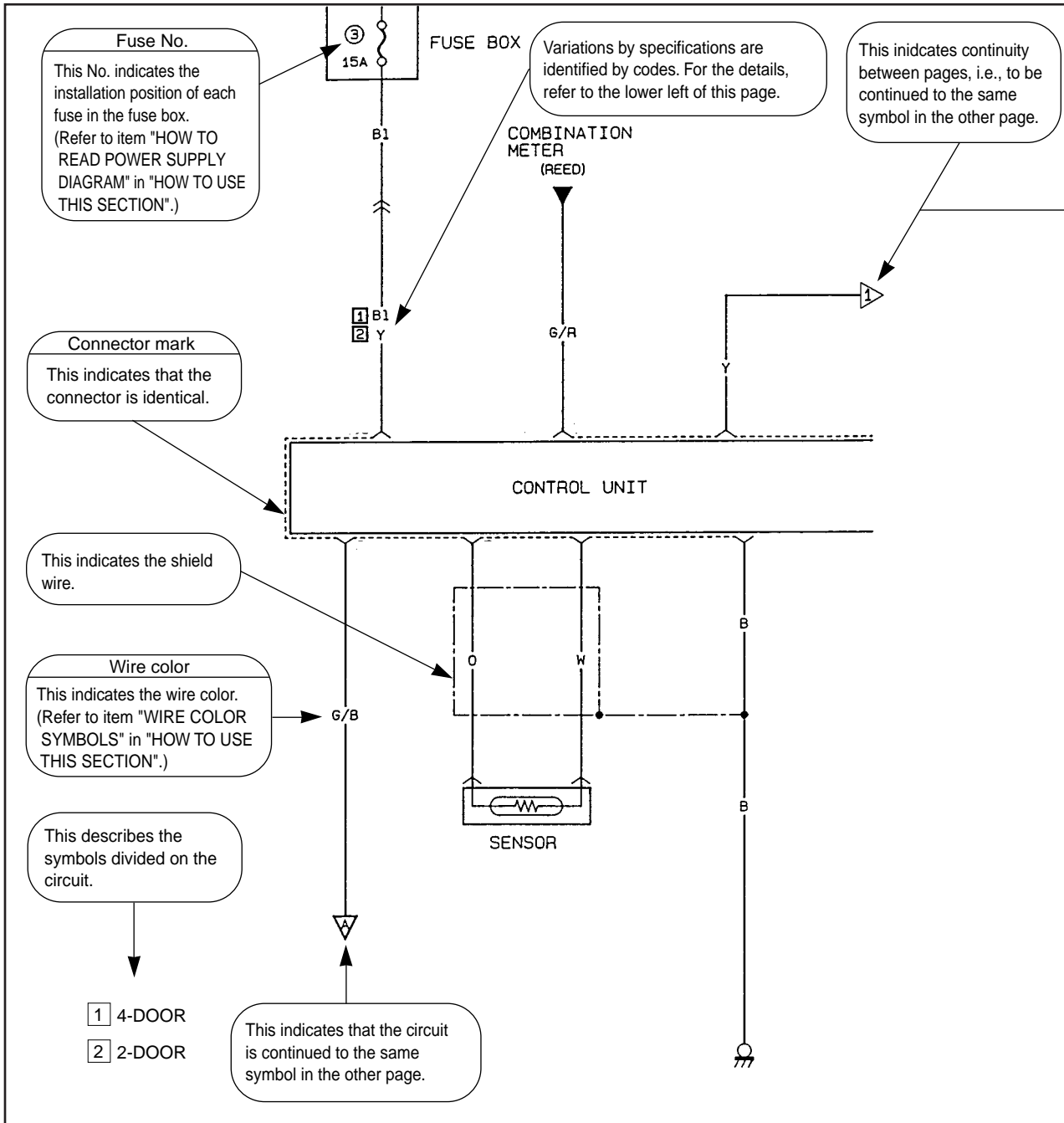

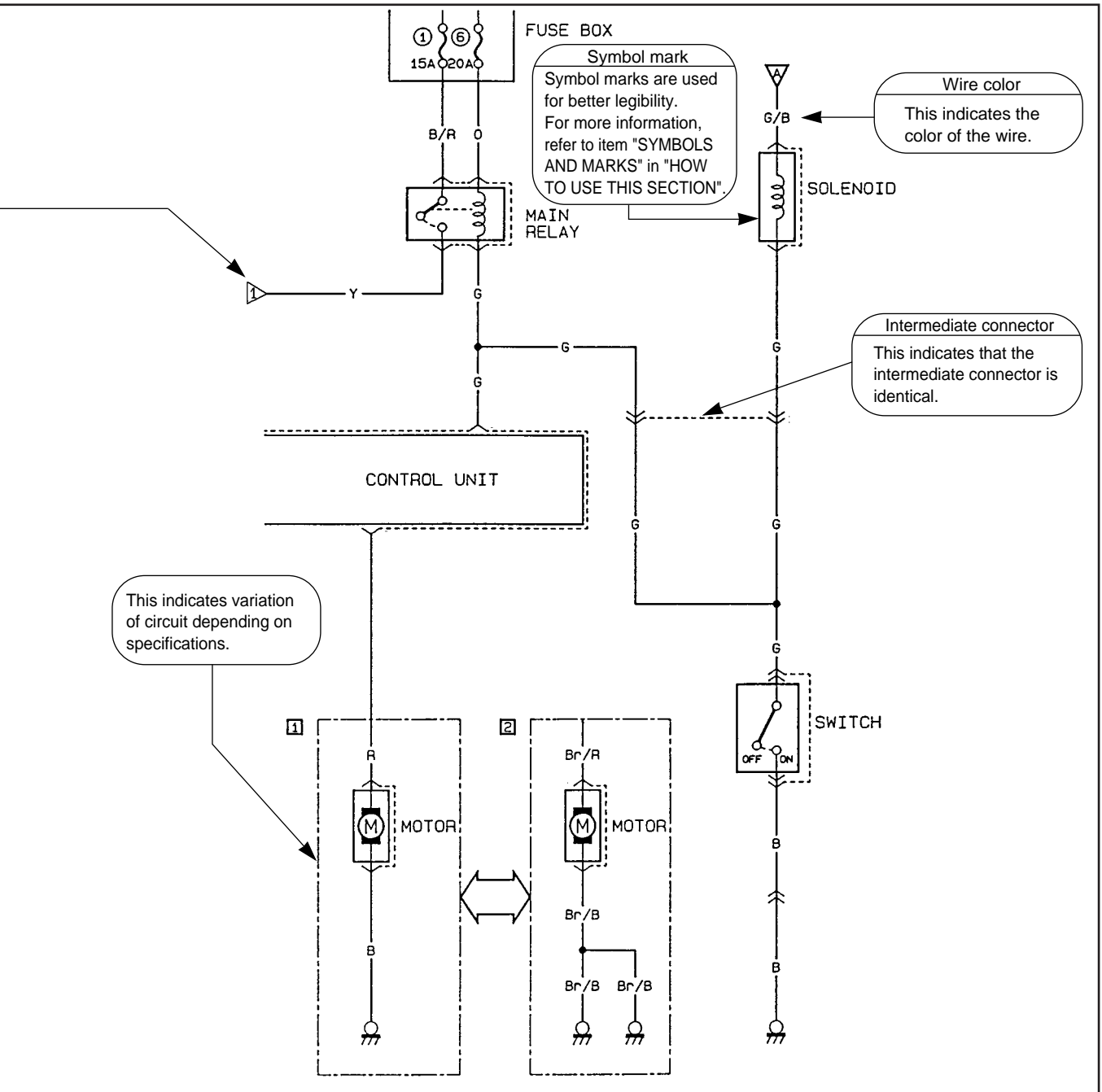

INDICATION OF CONNECTORS AND HOW TO READ THEM

Terminals of each connector are indicated by using symbolic illustrations in "SYSTEM CIRCUIT DIAGRAM" section in this manual. Shown below are examples accompanied by explanation of how to read them.

1. Male and female terminals of each connector connecting harnesses are shown as follows. When the connector is connected to the equipment directly, only the harness side terminal is indicated.

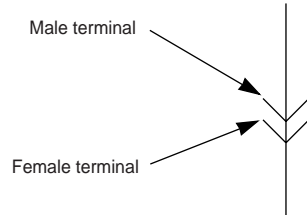

2. There are three types of connectors with respect to the way it is connected and each type is illustrated as shown below.

- To be inserted directly into equipment

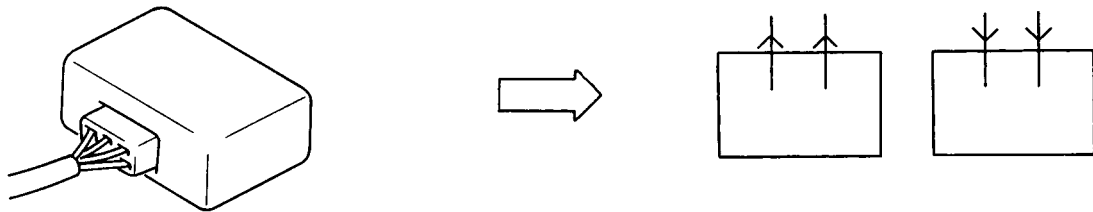

- To be connected with harness connector of equipment

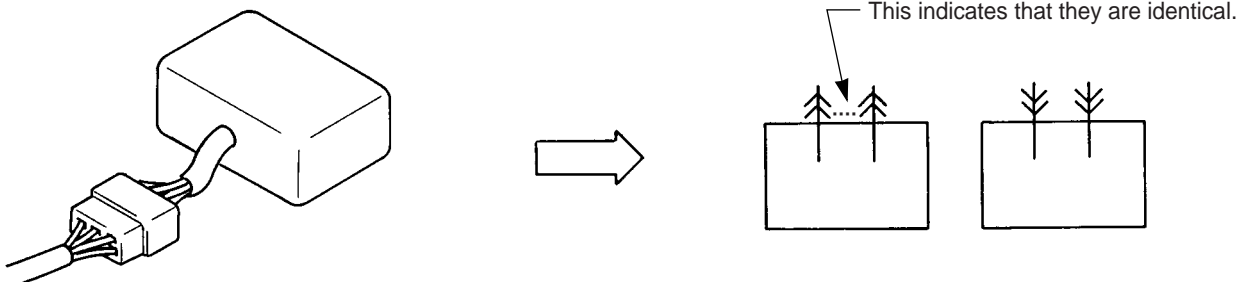

- To connect between harnesses (intermediate connector)

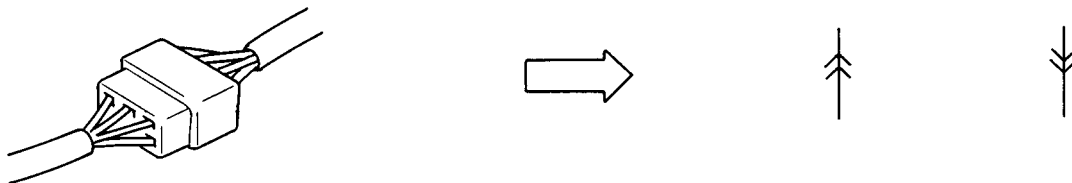

3. · Wiring of this vehicle employs joint connectors (J/C) which divide one wire into several different wires or combine several different wires into one wire.
- The joint connector is illustrated below.

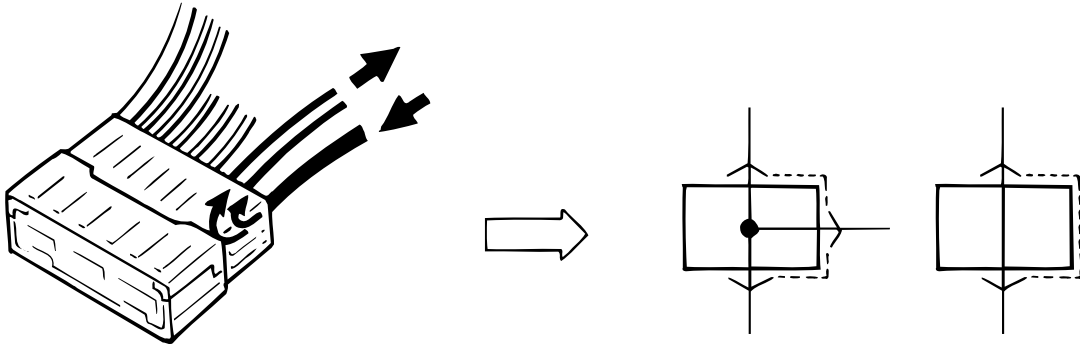

MEMO

SECTION 8A-4
ABSCHNITT 8A-4
SECTION 8A-4
SECCIÓN 8A-4

INSTALLATION POSITIONS OF SINGLE UNIT PARTS
EINBAUPOSITIONEN VON EINZELEINHEIT-TEILEN
POSITIONS D'INSTALLATION DES PIÈCES
INDIVIDUELLES
POSICIONES DE INSTALACIÓN DE PARTES DE
UNIDAD SENCILLA

8A-4

CONTENTS
INHALT
TABLE DES MATIÈRES
ÍNDICE

ENGINE ROOM (RIGHT HAND STEERING VEHICLE)	8A-4-2
ENGINE ROOM (LEFT HAND STEERING VEHICLE)	8A-4-4
INSTRUMENT PANEL (RIGHT HAND STEERING VEHICLE).....	8A-4-6
INSTRUMENT PANEL (LEFT HAND STEERING VEHICLE).....	8A-4-7
REAR	8A-4-8
MOTORRAUM (FAHRZEUG MIT RECHTSLENKUNG)	8A-4-2
MOTORRAUM (FAHRZEUG MIT LINKSLENKUNG)	8A-4-4
ARMATURENBRETT (FAHRZEUG MIT RECHTSLENKUNG)	8A-4-6
ARMATURENBRETT (FAHRZEUG MIT LINKSLENKUNG)	8A-4-7
HINTEN.....	8A-4-8
COMPARTIMENT MOTEUR (VEHICULE A CONDUITE A DROITE)	8A-4-2
COMPARTIMENT MOTEUR (VEHICULE A CONDUITE A GAUCHE)	8A-4-4
PANNEAU D'INSTRUMENTS (VEHICULE A CONDUITE A DROITE)	8A-4-6
PANNEAU D'INSTRUMENTS (VEHICULE A CONDUITE A GAUCHE).....	8A-4-7
ARRIÈRE.....	8A-4-8
COMPARTIMIENTO DEL MOTOR (VEHÍCULO CON DIRECCIÓN A LA DERECHA)	8A-4-2
COMPARTIMIENTO DEL MOTOR (VEHÍCULO CON DIRECCIÓN A LA IZQUIERDA)	8A-4-4
TABLERO DE INSTRUMENTOS (VEHÍCULO CON DIRECCIÓN A LA DERECHA).....	8A-4-6
TABLERO DE INSTRUMENTOS (VEHÍCULO CON DIRECCIÓN A LA IZQUIERDA).....	8A-4-7
PARTE TRASERA.....	8A-4-8

ENGINE ROOM (RIGHT HAND STEERING VEHICLE)

MOTORRAUM (FAHRZEUG MIT RECHTSLENKUNG)

COMPARTIMENT MOTEUR (VEHICULE A CONDUITE A DROITE)

COMPARTIMIENTO DEL MOTOR (VEHÍCULO CON DIRECCIÓN A LA DERECHA)

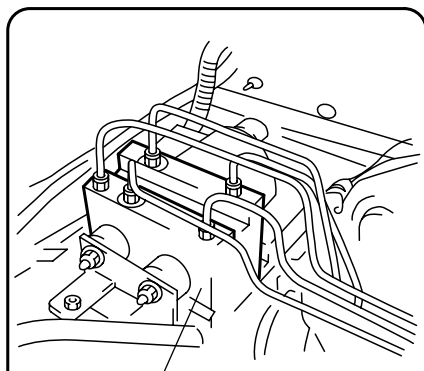

ABS CONTROLLER
ABS-STEUERGERÄT
COMMANDE DE L'ABS
CONTROLADOR DE SISTEMA DE FRENOS
ANTIENCLAVAMIENTO

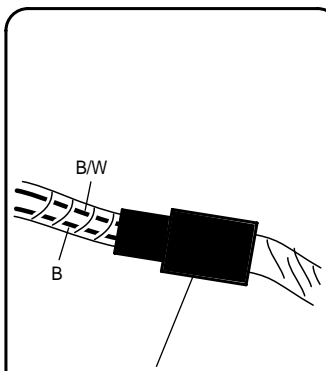

NOISE SUPPRESSOR
STÖRUNGSUNTERDRÜCKER
CONDENSATEUR ANTIPARASITE
SUPRESOR DE RUIDO

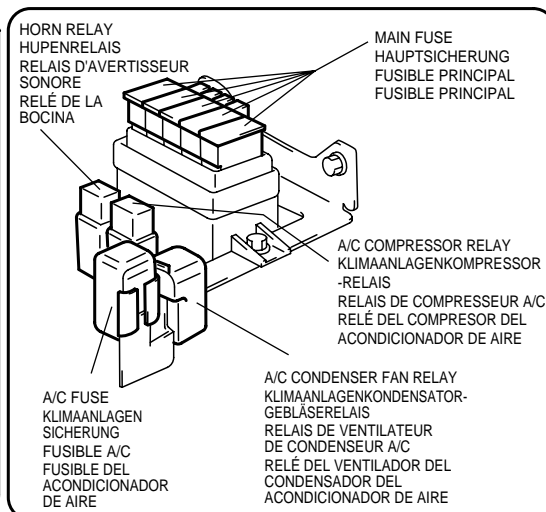

HORN RELAY
HUPENRELAIS
RELAIS D'AVERTISSEUR
SONORE
RELÉ DE LA BOCINA

MAIN FUSE
HAUPTSICHERUNG
FUSIBLE PRINCIPAL
FUSIBLE PRINCIPAL

A/C COMPRESSOR RELAY
KLIMAANLAGENKOMPRESSOR-
RELAIS
RELAIS DE COMPRESSEUR A/C
RELÉ DEL COMPRESOR DEL
ACONDICIONADOR DE AIRE

A/C FUSE
KLIMAANLAGEN
SICHERUNG
FUSIBLE A/C
FUSIBLE DEL
ACONDICIONADOR
DE AIRE

A/C CONDENSER FAN RELAY
KLIMAANLAGENKONDENSATOR-
GEBLÄSERRELAIS
RELAIS DE VENTILATEUR
DE CONDENSEUR A/C
RELÉ DEL VENTILADOR DEL
CONDENSADOR DEL
ACONDICIONADOR DE AIRE

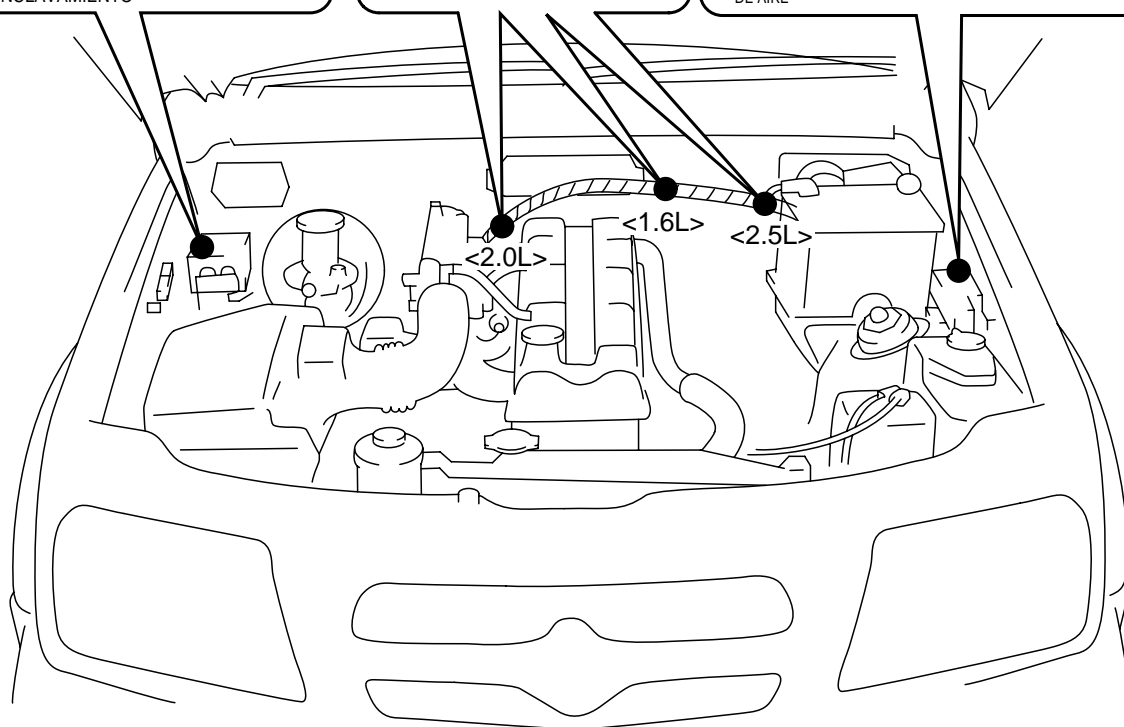

- *This illustration is 2.0L model
- *Diese Abbildung zeigt das 2,0-Liter-Modell
- *Cette illustration représente le modèle 2,0 litres
- *Esta ilustración es del modelo 2.0L

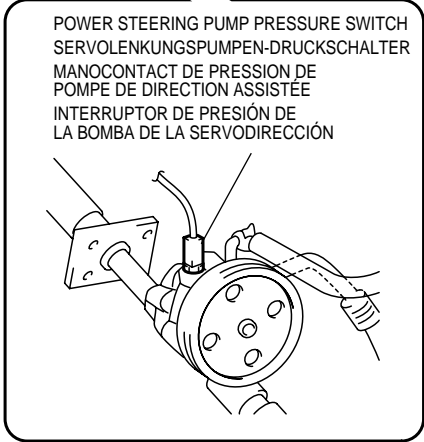
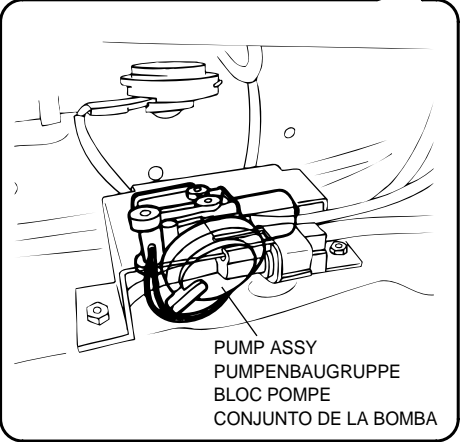
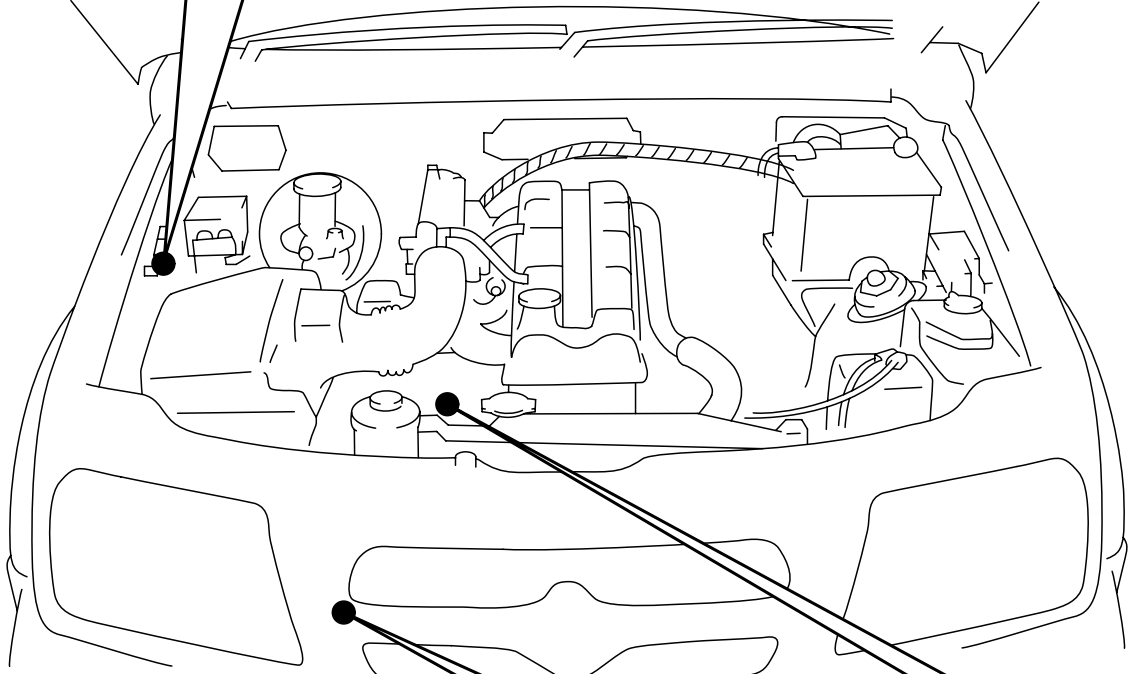
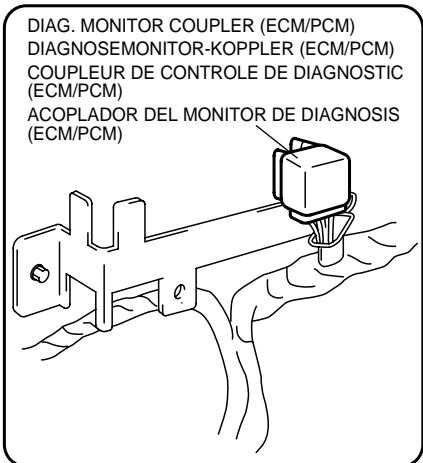

* This illustration is 2.0L model
 *Diese Abbildung zeigt das 2,0-Liter-Modell
 *Cette illustration représente le modèle 2,0 litres
 *Esta ilustración es del modelo 2.0L

ENGINE ROOM (LEFT HAND STEERING VEHICLE)

MOTORRAUM (FAHRZEUG MIT LINKSLENKUNG)

COMPARTIMENT MOTEUR (VEHICULE A CONDUITE A GAUCHE)

COMPARTIMIENTO DEL MOTOR (VEHÍCULO CON DIRECCIÓN A LA IZQUIERDA)

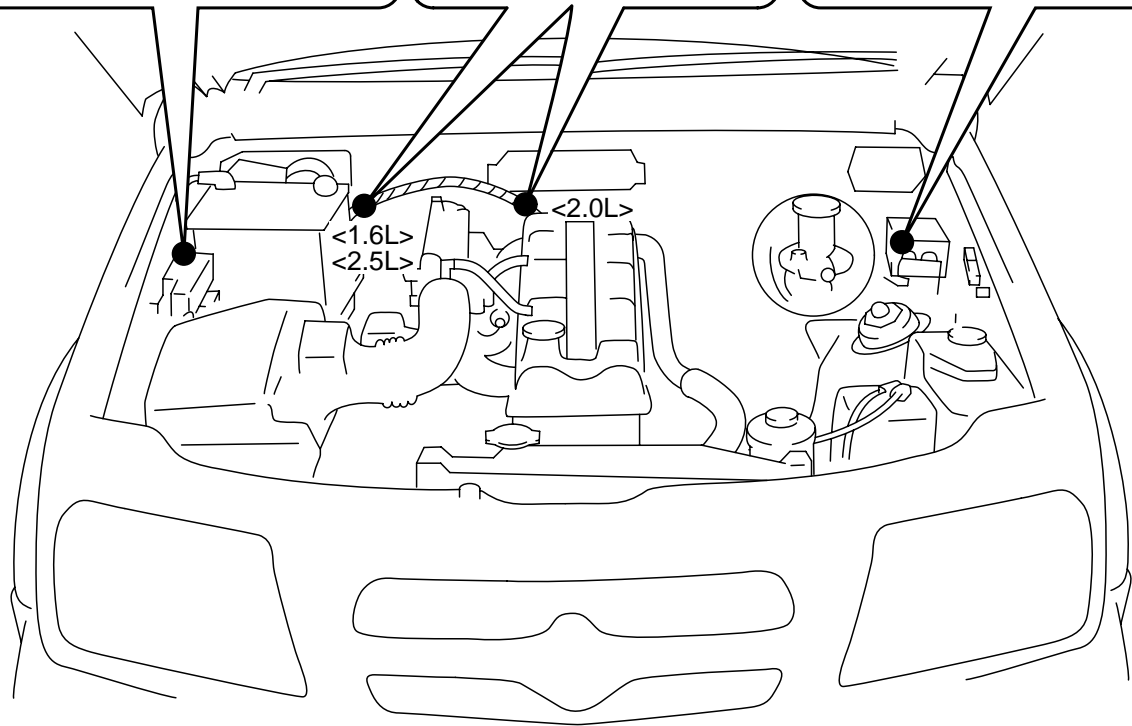
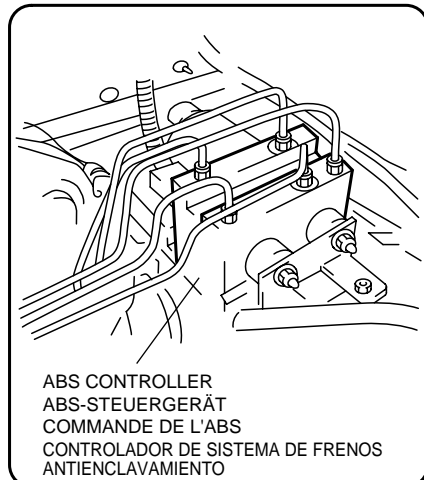
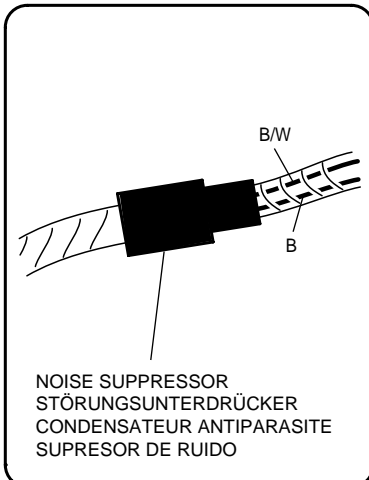
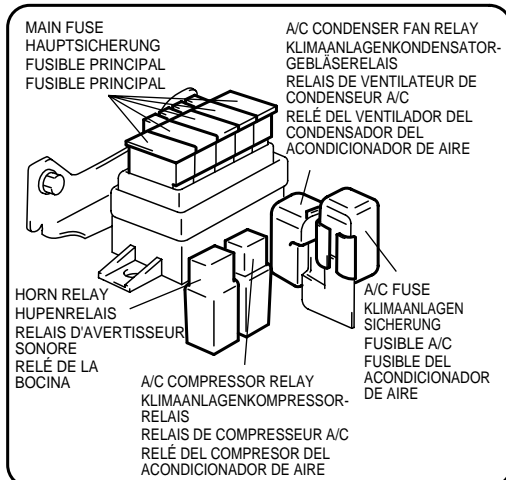

* This illustration is 2.0L model

*Diese Abbildung zeigt das 2,0-Liter-Modell

*Cette illustration représente le modèle 2,0 litres

*Esta ilustración es del modelo 2.0L

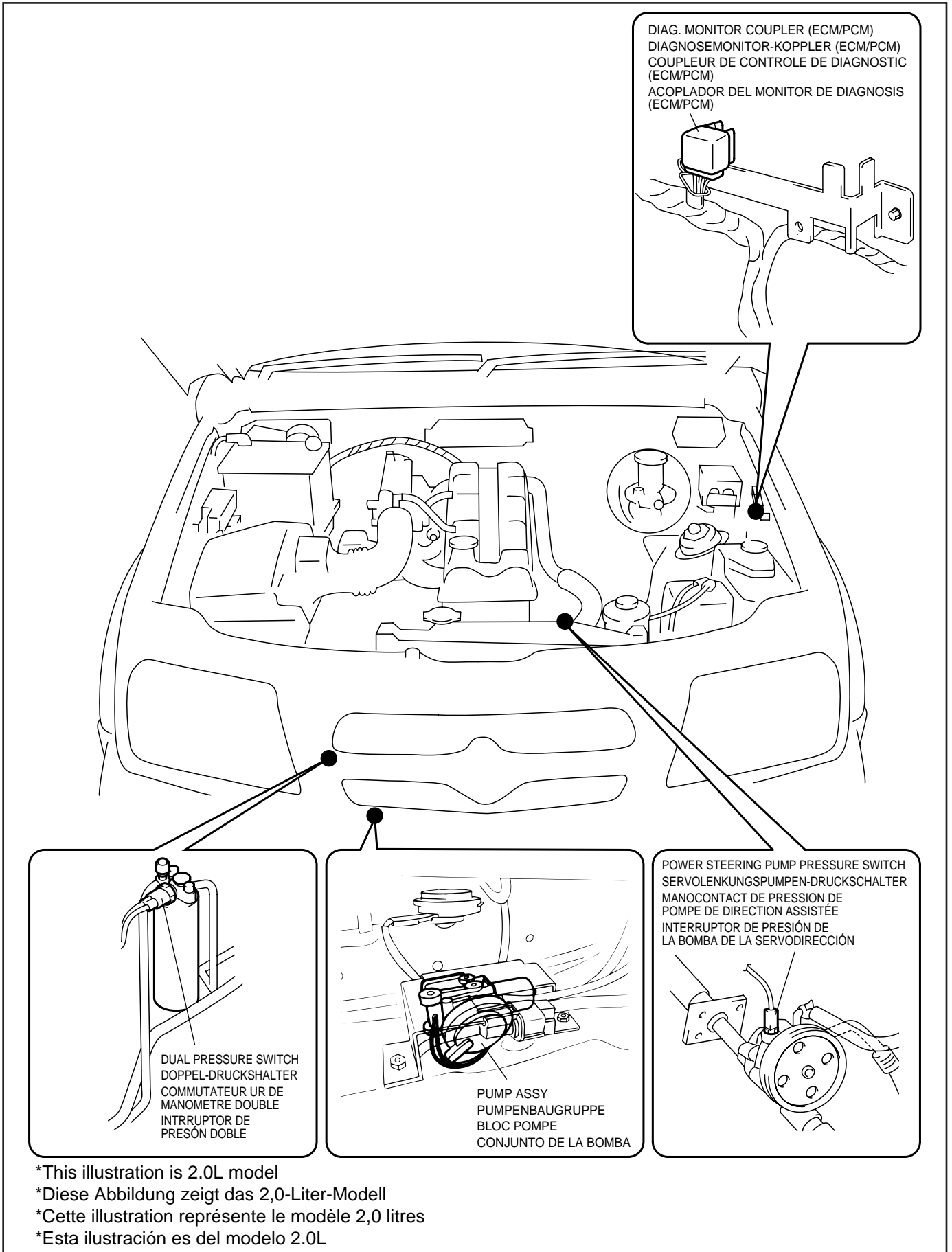

*This illustration is 2.0L model
 *Diese Abbildung zeigt das 2,0-Liter-Modell
 *Cette illustration représente le modèle 2,0 litres
 *Esta ilustración es del modelo 2.0L

INSTRUMENT PANEL (RIGHT HAND STEERING VEHICLE)

ARMATURENBRETT (FAHRZEUG MIT RECHTSLENKUNG)

PANNEAU D'INSTRUMENTS (VEHICULE A CONDUITE A DROITE)

TABLERO DE INSTRUMENTOS (VEHÍCULO CON DIRECCIÓN A LA DERECHA)

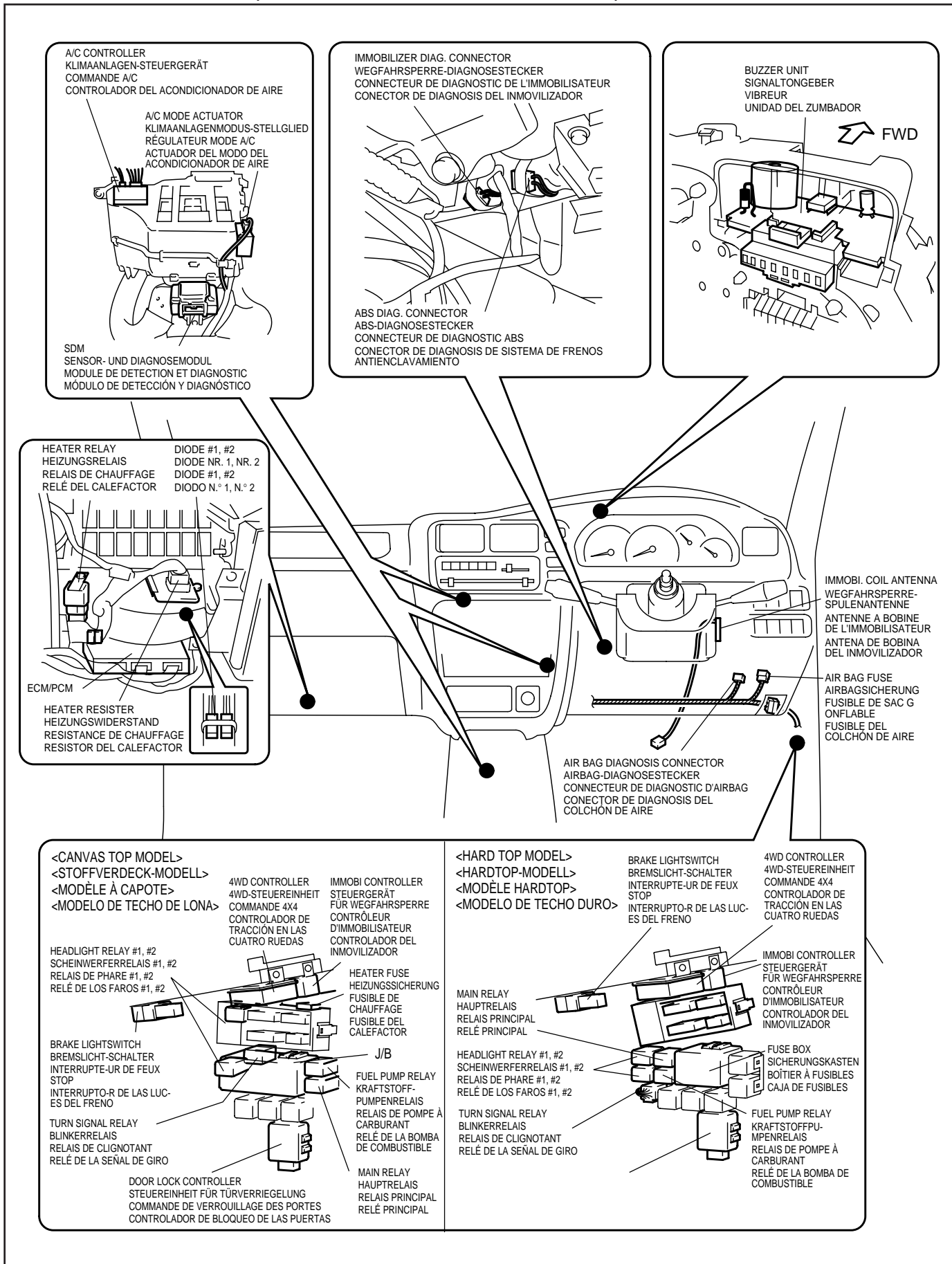

INSTRUMENT PANEL (LEFT HAND STEERING VEHICLE)
ARMATURENBRETT (FAHRZEUG MIT LINKSLENKUNG)
PANNEAU D'INSTRUMENTS (VEHICULE A CONDUITE A GAUCHE)
TABLERO DE INSTRUMENTOS (VEHÍCULO CON DIRECCIÓN A LA IZQUIERDA)

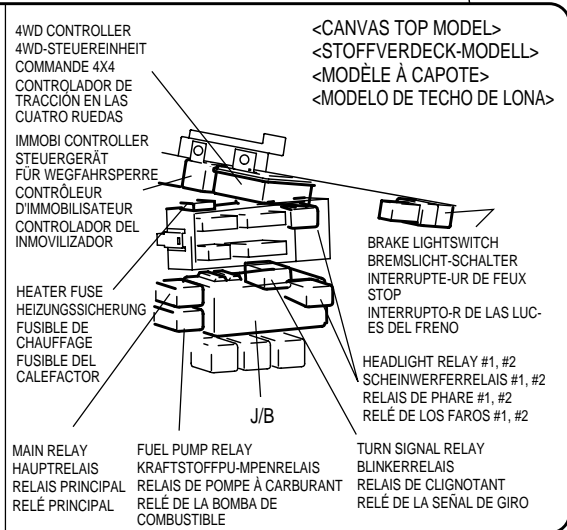
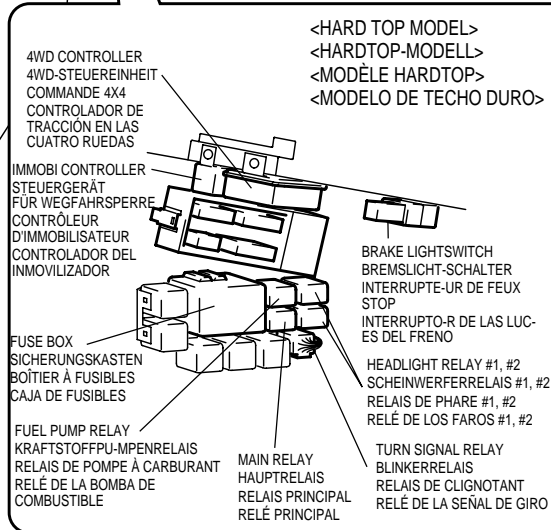
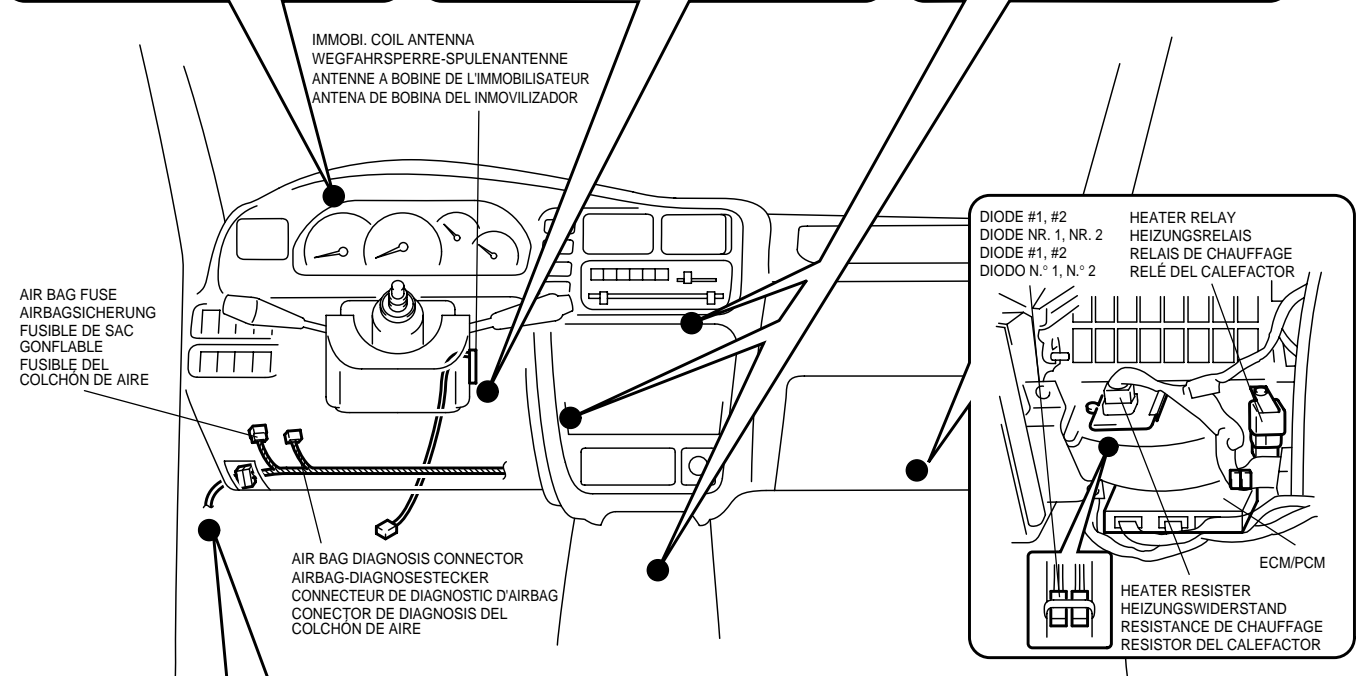
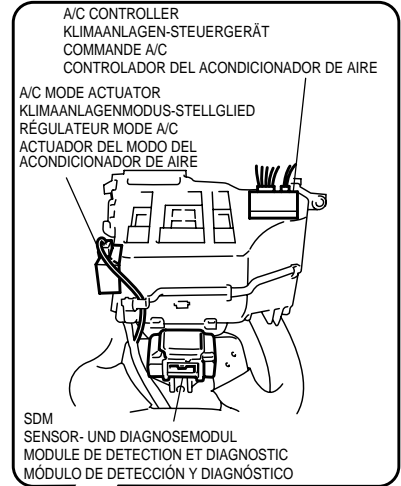
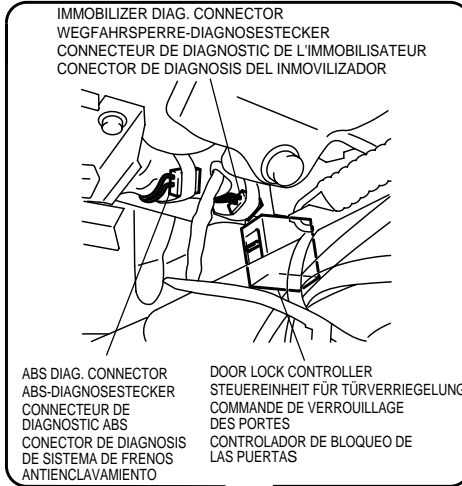
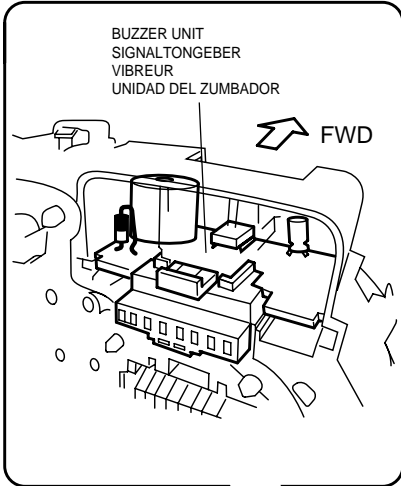

REAR
HINTEN
ARRIÈRE
PORTE TRASERA

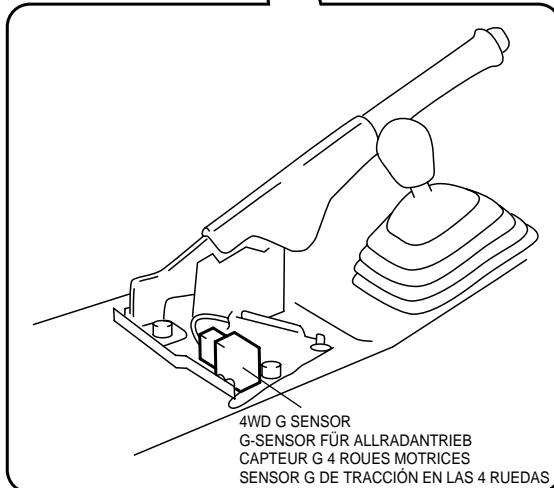
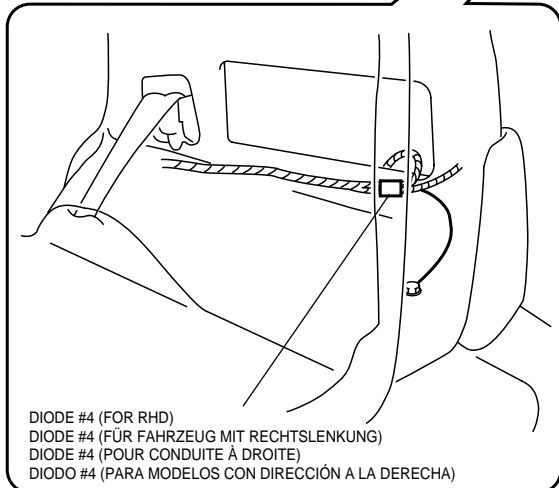
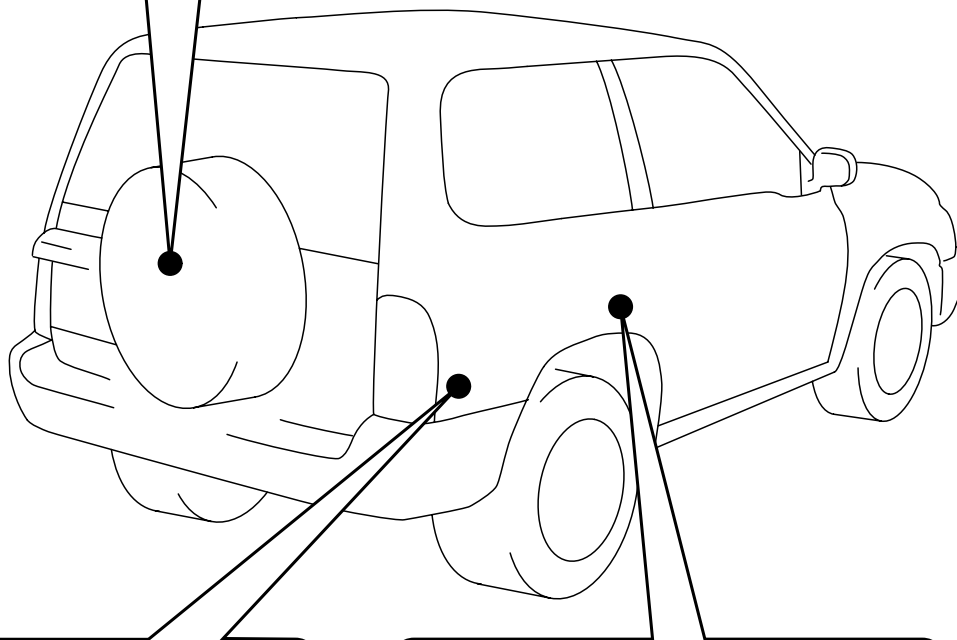
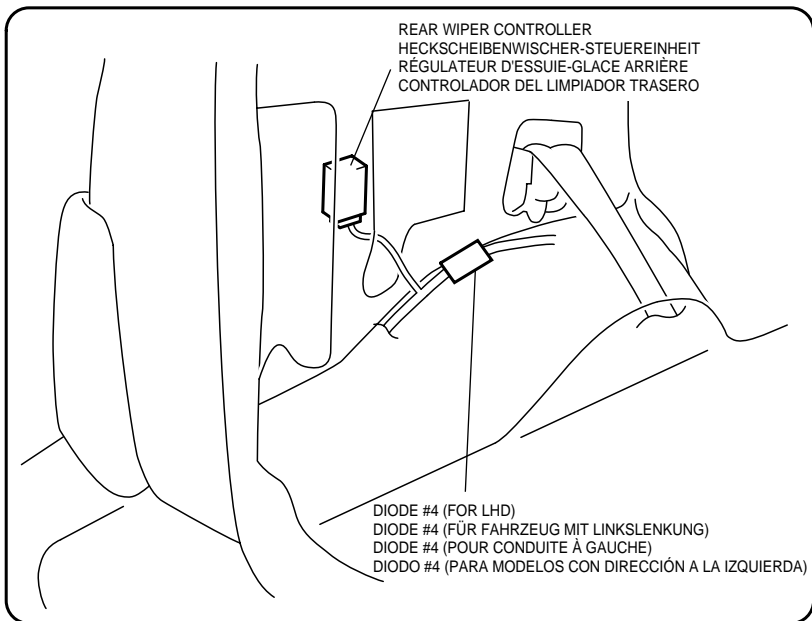

SECTION 8A-5
ABSCHNITT 8A-5
SECTION 8A-5
SECCIÓN 8A-5

GROUND POINT
MASSEPUNKT
POINTS DE MASSE
POINTS DE MASA

8A-5

CONTENTS
INHALT
TABLE DES MATIÈRES
ÍNDICE

· ENGINE ROOM (RIGHT HAND STEERING VEHICLE)	8A-5-2
· ENGINE ROOM (LEFT HAND STEERING VEHICLE)	8A-5-3
· INSTRUMENT PANEL	8A-5-4
· BACK DOOR	8A-5-5
· MOTORRAUM (FAHRZEUG MIT RECHTSLENKUNG)	8A-5-2
· MOTORRAUM (FAHRZEUG MIT LINKSLENKUNG)	8A-5-3
· ARMATURENBRETT	8A-5-4
· HECKKLAPPE	8A-5-5
· COMPARTIMENT MOTEUR (VEHICULE A CONDUITE A DROITE)	8A-5-2
· COMPARTIMENT MOTEUR (VEHICULE A CONDUITE A GAUCHE)	8A-5-3
· PANNEAU D'INSTRUMENTS	8A-5-4
· PORTE ARRIERE	8A-5-5
· COMPARTIMIENTO DEL MOTOR (VEHÍCULO CON DIRECCIÓN A LA DERECHA)	8A-5-2
· COMPARTIMIENTO DEL MOTOR (VEHÍCULO CON DIRECCIÓN A LA IZQUIERDA)	8A-5-3
· TABLERO DE INSTRUMENTOS	8A-5-4
· PUERTA POSTERIOR	8A-5-5

ENGINE ROOM (RIGHT HAND STEERING VEHICLE)

MOTORRAUM (FAHRZEUG MIT RECHTSLENKUNG)

COMPARTIMENT MOTEUR (VEHICULE A CONDUITE A DROITE)

COMPARTIMIENTO DEL MOTOR (VEHÍCULO CON DIRECCIÓN A LA DERECHA)

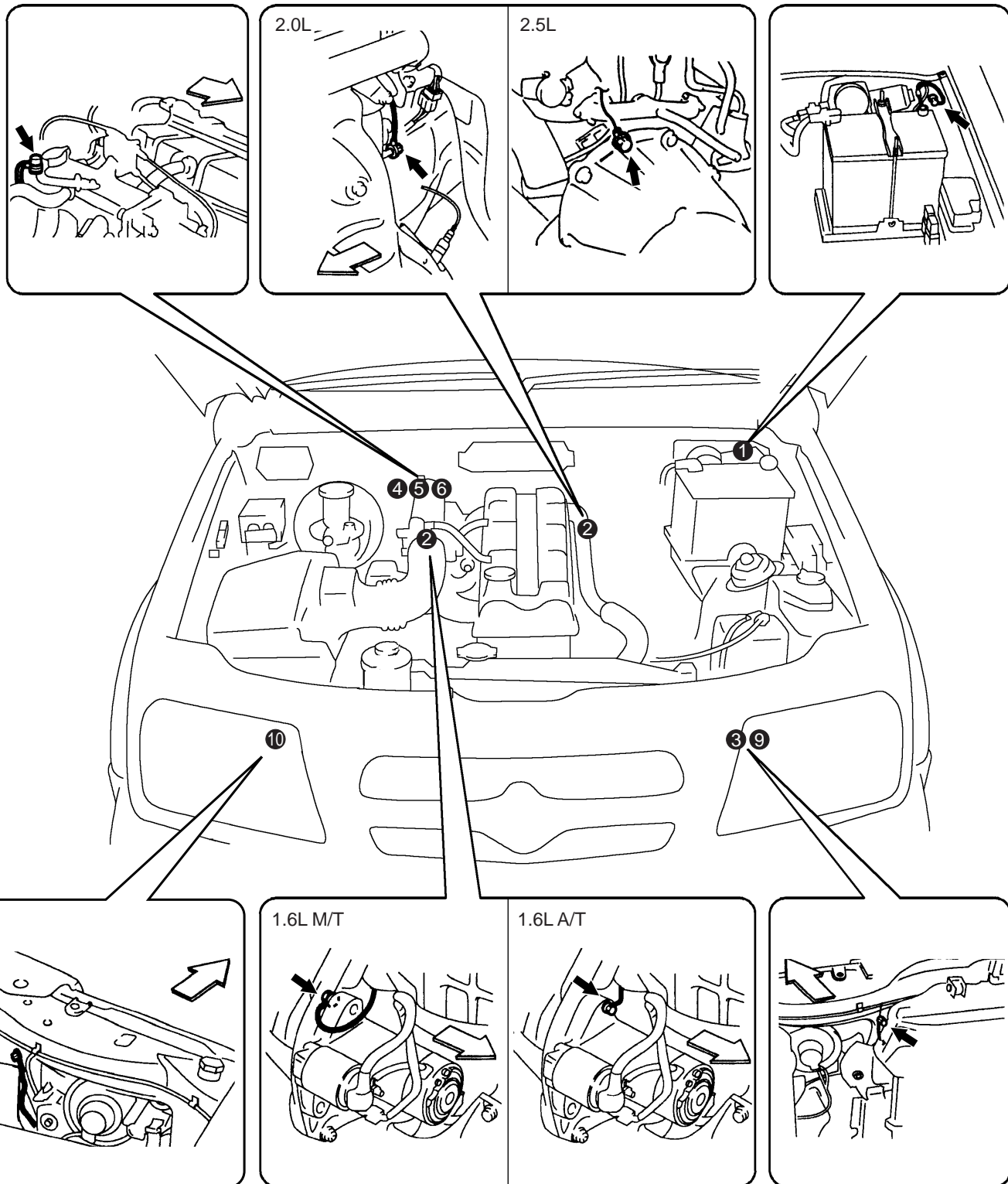

NOTE: The illustration is for 2.0L model and ground points for 1.6L & 2.5L are all alike.

HINWEIS: Die Abbildung zeigt das 2,0-Liter-Modell, aber die Massepunkte für die 1,6-Liter- und 2,5-Liter-Modelle sind die gleichen.

REMARQUE: L'illustration du modèle 2,0 litres et les contacts de mise à la masse des modèles 1,6 litre et 2,5 litres sont identiques.

NOTA: La ilustración es para el modelo 2.0L y los puntos de tierra para los modelos 1.6L y 2.5L son todos los mismos.

ENGINE ROOM (LEFT HAND STEERING VEHICLE)
MOTORRAUM (FAHRZEUG MIT LINKSLENKUNG)
COMPARTIMENT MOTEUR (VEHICULE A CONDUITE A GAUCHE)
COMPARTIMIENTO DEL MOTOR (VEHÍCULO CON DIRECCIÓN A LA IZQUIERDA)

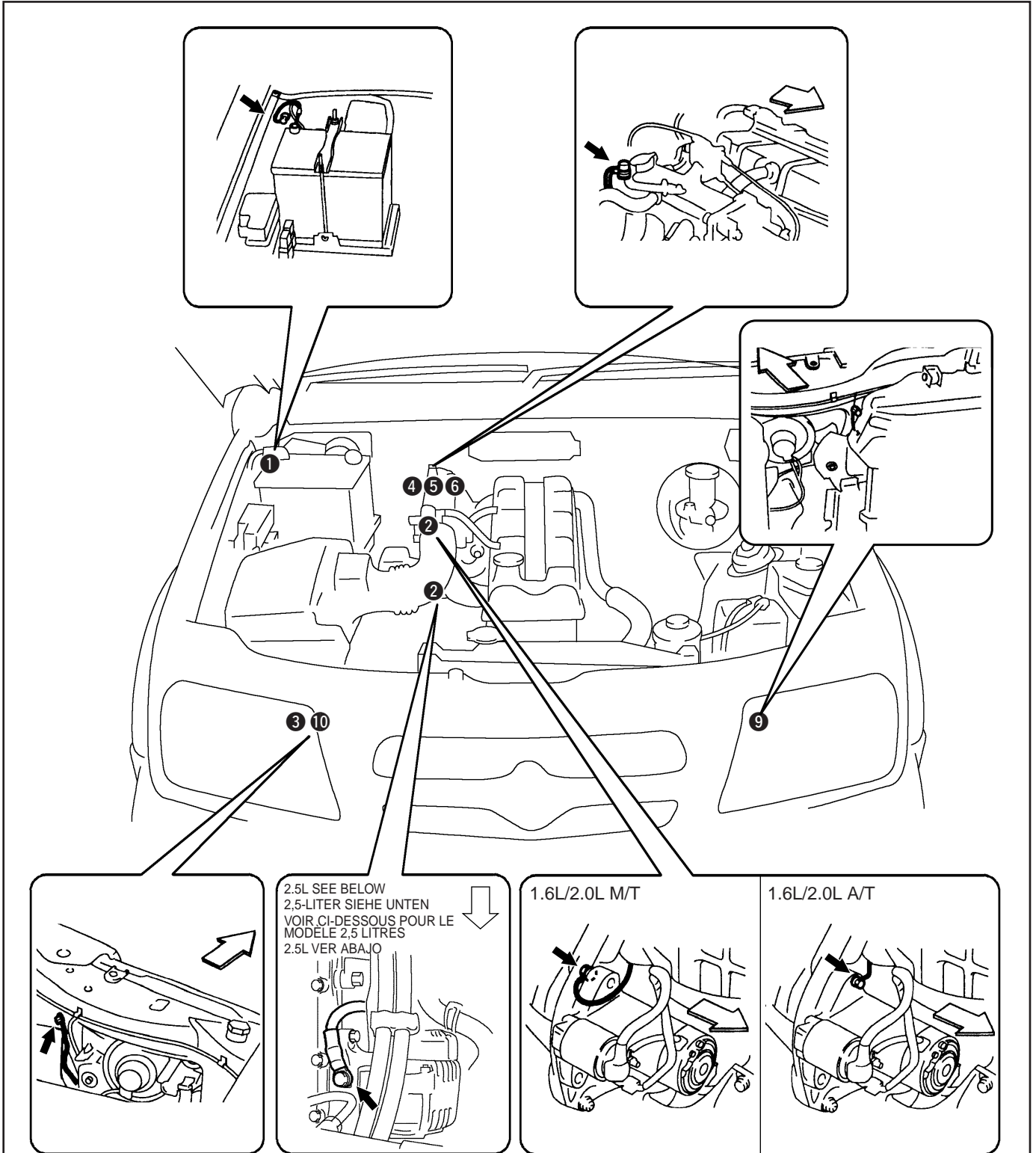

2.5L SEE BELOW
2,5-LITER SIEHE UNTEN
VOIR CI-DESSOUS POUR LE
MODELE 2.5 LITRES
2.5L VER ABAJO

1.6L/2.0L M/T

1.6L/2.0L A/T

VIEW FROM UNDER THE E/G ROOM
SICHT VON UNTER DEM MOTORRAUM
VUE A PARTIR DU COMPARTIMENT MOTEUR
VISTA DESDE DEBAJO DEL COMPARTIMIENTO DEL MOTOR

NOTE: The illustration is for 2.0L model and ground points for 1.6L & 2.5L are all alike.
HINWEIS: Die Abbildung zeigt das 2,0-Liter-Modell, aber die Massepunkte für die 1,6-Liter- und 2,5-Liter-Modelle sind die gleichen.
REMARQUE: L'illustration du modèle 2,0 litres et les contacts de mise à la masse des modèles 1,6 litre et 2,5 litres sont identiques.
NOTA: La ilustración es para el modelo 2.0L y los puntos de tierra para los modelos 1.6L y 2.5L son todos los mismos.

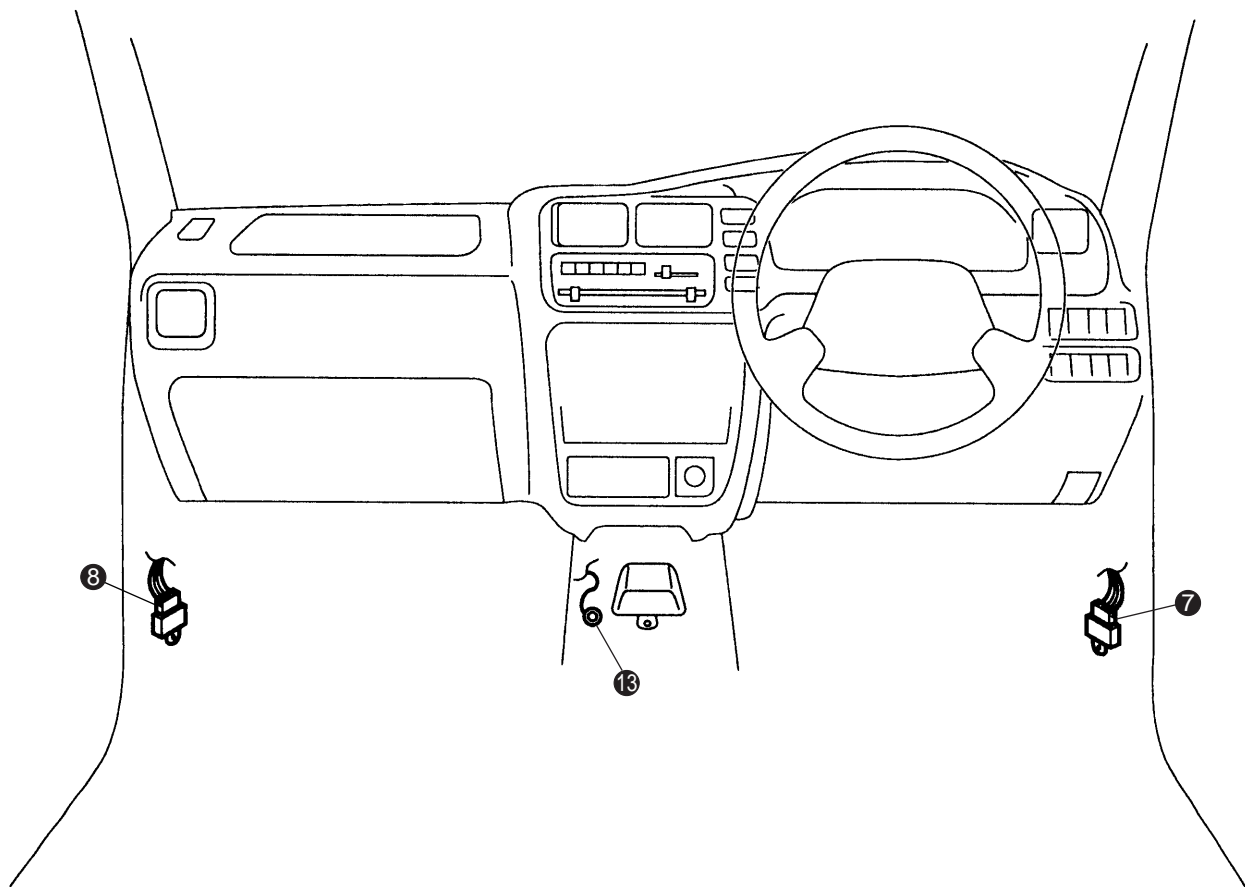
INSTRUMENT PANEL**ARMATURENBRETT****PANNEAU D'INSTRUMENTS****TABLERO DE INSTRUMENTOS**

NOTE: The illustration is for RHD. LHD view is symmetrical;

⑦ is at the driver side and ⑧ is at the passenger side.

HINWEIS: Die Abbildung für die Sicht für Fahrzeug mit Links- und Rechtslenkung ist symmetrisch;

⑦ ist auf der Fahrerseite und ⑧ ist auf der Beifahrerseite.

REMARQUE: L'illustration représente le modèle à conduite à droite. La représentation du modèle à conduite à gauche est symétriquement opposée; ⑦ est sur le côté conducteur et ⑧ sur le côté passager.

NOTA: La ilustración es para el modelos con dirección a la derecha. La vista para el modelo con dirección a la izquierda es simétrica; ⑦ está en el lado del conductor y ⑧ está en el lado del pasajero.

BACK DOOR
HECKKLAPPE
PORTE ARRIERE
PUERTA POSTERIOR

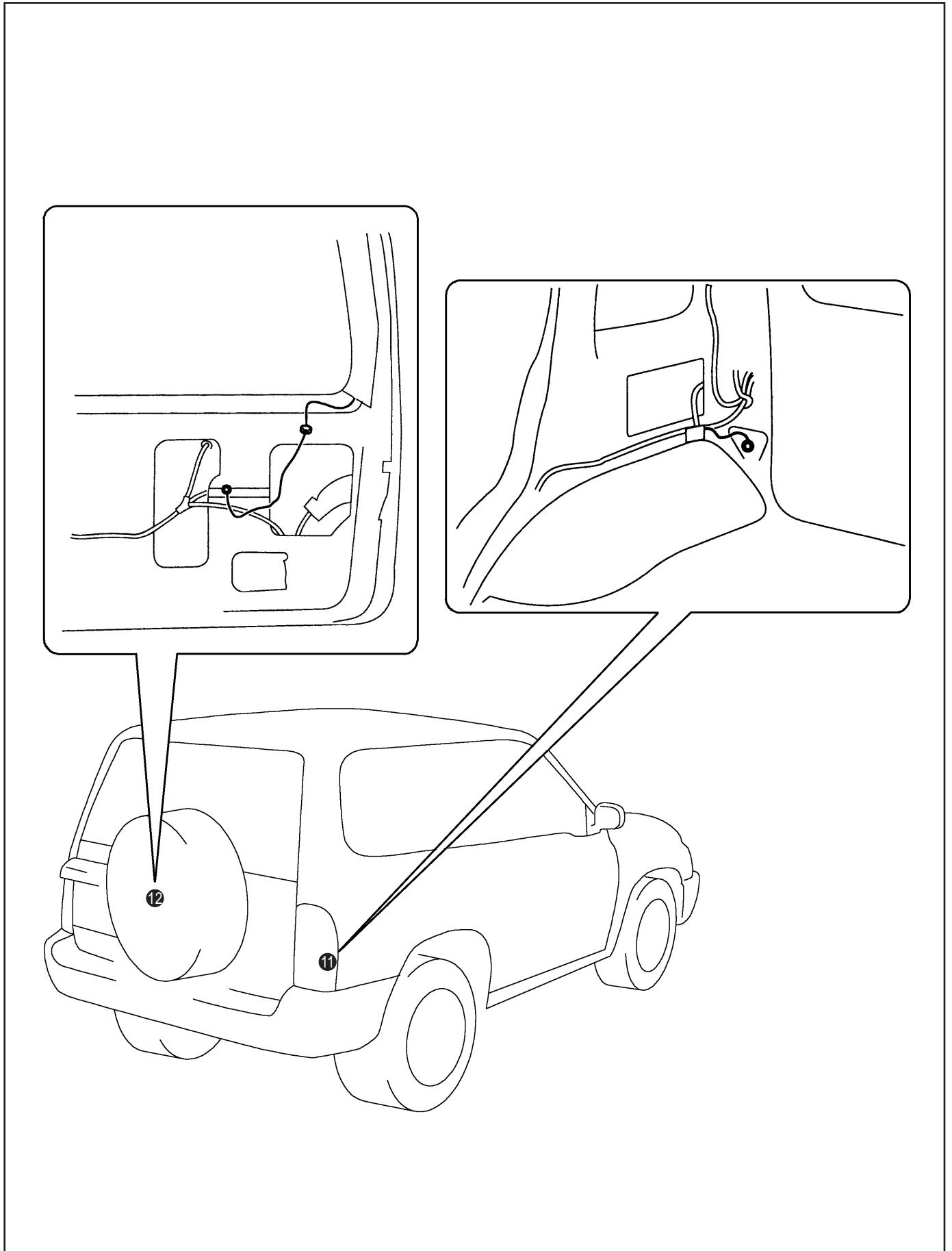

SECTION 8A-6
ABSCHNITT 8A-6
SECTION 8A-6
SECCIÓN 8A-6

POWER SUPPLY DIAGRAM
STROMVERSORGUNGSDIAGRAMM
SCHÉMA DU CIRCUIT D'ALIMENTATION
DIAGRAMA DE ALIMENTACIÓN ELÉCTRICA

CONTENTS
INHALT
TABLE DES MATIÈRES
ÍNDICE

· POWER SUPPLY DIAGRAM.....	8A-6-2
· MAIN FUSE	8A-6-3
· FUSE	8A-6-3
· STROMVERSORGUNGSDIAGRAMM.....	8A-6-2
· HAUPTSICHERUNG	8A-6-3
· SICHERUNG	8A-6-3
· SCHÉMA DU CIRCUIT D'ALIMENTATION.....	8A-6-2
· FUSIBLE PRINCIPAL	8A-6-3
· FUSIBLE	8A-6-3
· DIAGRAMA DE ALIMENTACIÓN ELÉCTRICA.....	8A-6-2
· FUSIBLE PRINCIPAL	8A-6-3
· FUSIBLE	8A-6-3

POWER SUPPLY DIAGRAM

STROMVERSORGUNGSDIAGRAMM

SCHEMA DU CIRCUIT D'ALIMENTATION

DIAGRAMA DE ALIMENTACIÓN ELÉCTRICA

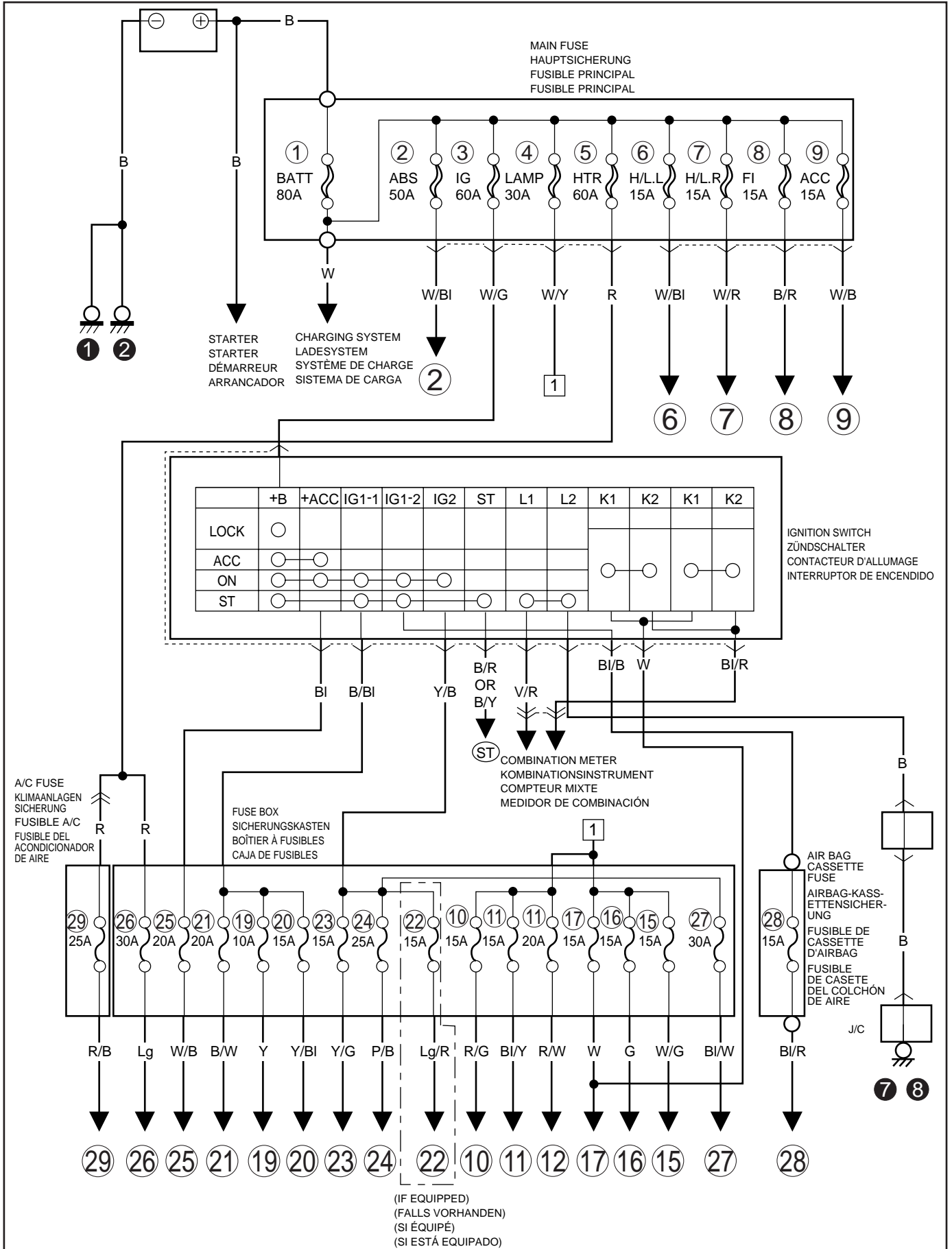

**MAIN FUSE
 HAUPTSICHERUNG
 FUSIBLE PRINCIPAL
 FUSIBLE PRINCIPAL**

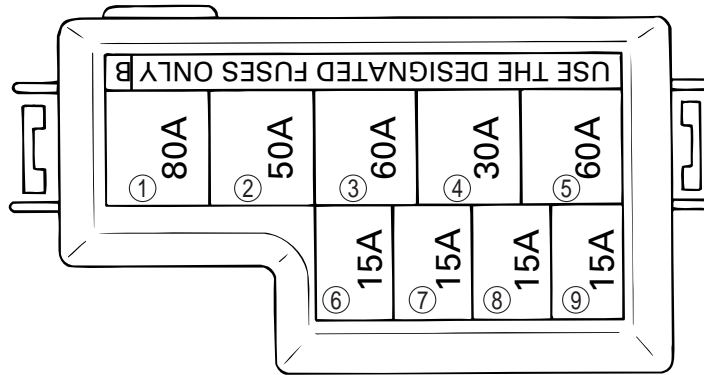

**FUSE
 SICHERUNG
 FUSIBLE
 FUSIBLE**

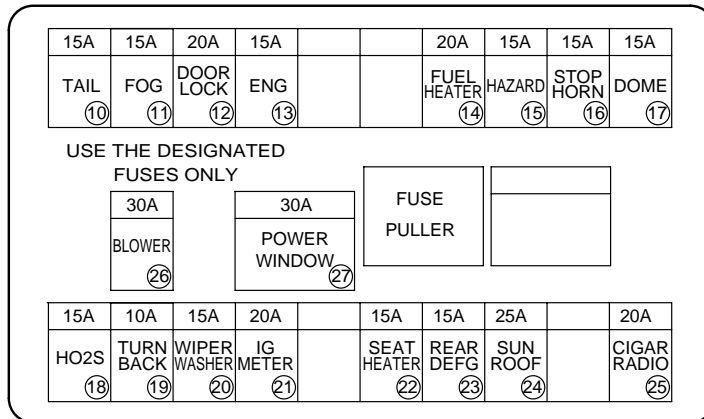

NOTE :
 The number at each fuse corresponds to that of Power Supply Diagram (8A-6-2) or System Circuit Diagram (8A-7).

HINWEIS:
 Die Nummer jeder Sicherung entspricht der jeweiligen Nummer auf dem Stromversorgungsdiagramm (8A-6-2) oder Systemschaltdiagramm (8A-7).

REMARQUE:
 Le numéro de chaque fusible correspond à celui indiqué sur le schéma du circuit d'alimentation (8A-6-2) ou du schéma des circuits électriques (8A-7).

NOTA:
 El número de cada fusible corresponde al del diagrama de alimentación eléctrica (8A-6-2) o diagrama del circuito del sistema (8A-7).

SECTION 8A-7

SYSTEM CIRCUIT DIAGRAM

CONTENTS

CRANKING SYSTEM	8A-7-9
CHARGING SYSTEM	8A-7-10
IMMOBILIZER CONTROL SYSTEM	8A-7-11
IGNITION, ENGINE & EMISSION CONTROL SYSTEM (M/T MODEL OF G16B, J20A ENGINE)	8A-7-12
IGNITION, ENGINE & EMISSION & A/T CONTROL SYSTEM (A/T MODEL OF G16B, J20A ENGINE)	8A-7-16
IGNITION, ENGINE & EMISSION CONTROL SYSTEM (M/T MODEL OF H25A ENGINE)	8A-7-22
IGNITION, ENGINE & EMISSION & A/T CONTROL SYSTEM (A/T MODEL OF H25A ENGINE)	8A-7-26
4WD CONTROL SYSTEM	8A-7-32
SLIDING ROOF	8A-7-33
WINDSHIELD WIPER & WASHER	8A-7-34
REAR WIPER & WASHER	8A-7-35
REAR WINDOW DEFOGGER	8A-7-36
POWER WINDOW	8A-7-38
POWER DOOR LOCK	8A-7-40
REMOTE CONTROLLED MIRROR	8A-7-42
HORN	8A-7-43
METER & GAUGE	8A-7-44
INDICATOR LAMP	8A-7-45
INDICATOR LAMP	8A-7-46
WARNING LAMP	8A-7-48
HEADLIGHT SYSTEM	8A-7-50
POSITION, TAIL AND LICENSE PLATE LIGHT	8A-7-52
ILLUMINATION LAMP (RIGHT HAND STEERING VEHICLE)	8A-7-54
ILLUMINATION LAMP (LEFT HAND STEERING VEHICLE)	8A-7-56
ROOM LIGHT	8A-7-58
TURN SIGNAL AND HAZARD WARNING LIGHT	8A-7-60
BRAKE LIGHT	8A-7-62

BUCK-UP LIGHT	8A-7-63
HEATER AND AIR CONDITIONIG	8A-7-65
RADIO.....	8A-7-68
CLOCK.....	8A-7-69
CIGAR LIGHTER	8A-7-70
WARNING BUZZER	8A-7-71
AIR-BAG CONTROL SYSTEM.....	8A-7-72
ANTI-LOCK BRAKE SYSTEM.....	8A-7-74
REAR FOG LIGHT.....	8A-7-76
HEADLIGHT BEAM LEVELING SYSTEM.....	8A-7-78

CRANKING SYSTEM
KURBELSYSTEM
SYSTÈME DE DÉMARRAGE
SISTEMA DE ARRANQUE

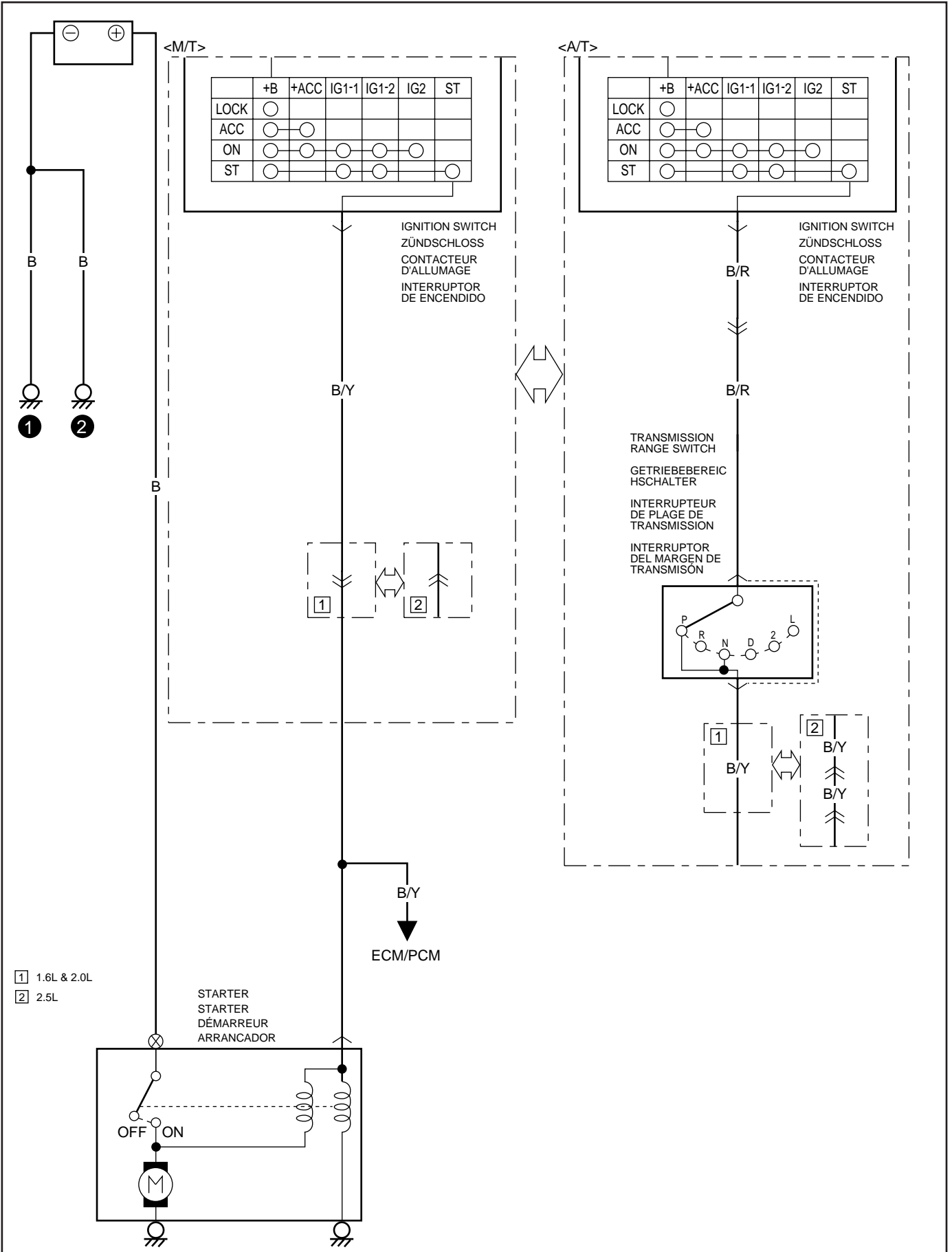

CHARGING SYSTEM

LADESYSTEM

SYSTÈME DE CHARGE

SISTEMA DE CARGA

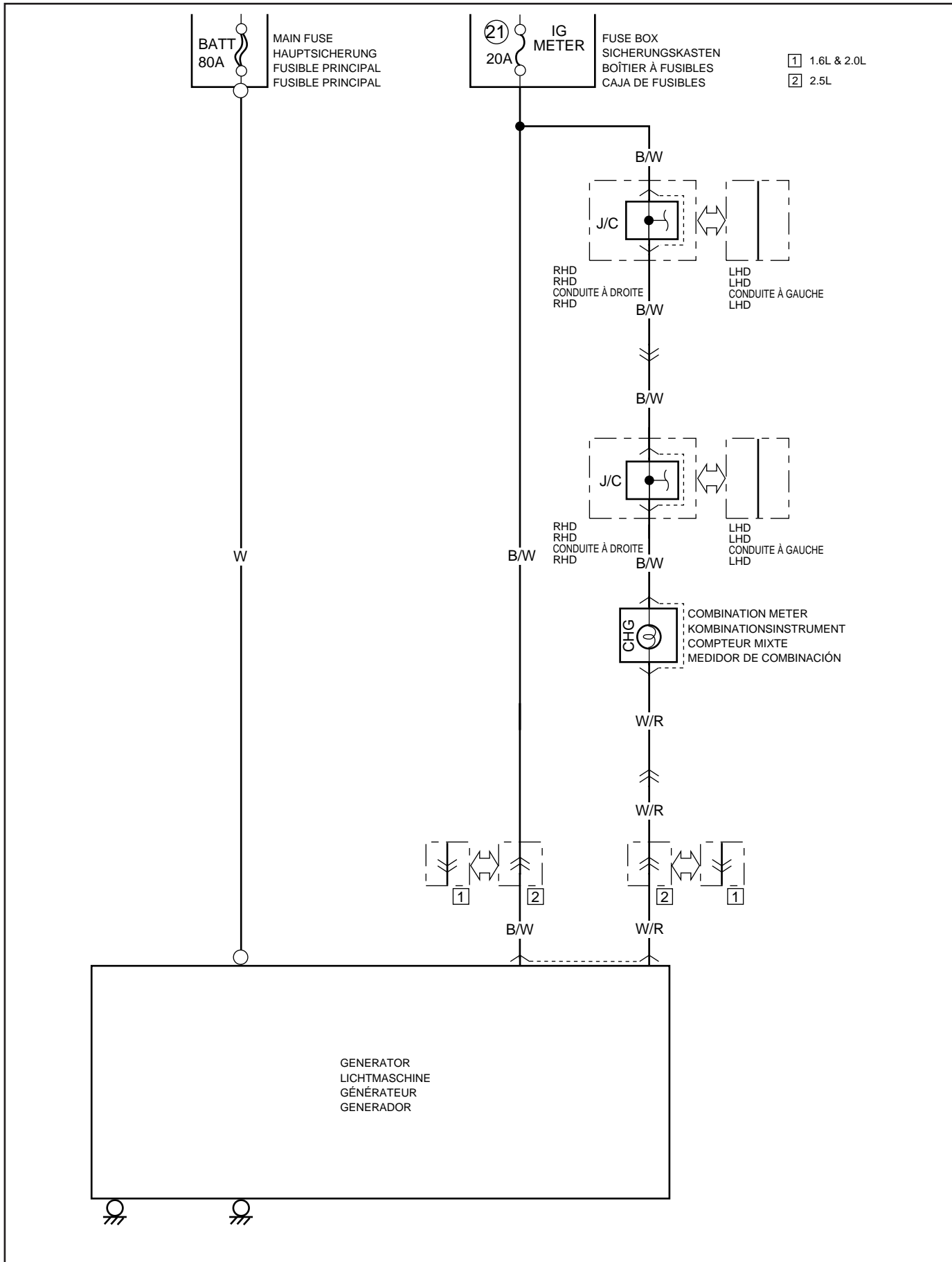

IGNITION, ENGINE & EMISSION CONTROL SYSTEM (M/T MODEL OF G16B, J20A ENGINE)
ZÜNDUNGS-, MOTOR- UND ABGASREGELSYSTEM (SCHALTGETRIEBEVERSION VON G16B, J20A MOTOR)
SYSTÈME DE COMMANDE DE L'ALLUMAGE, MOTEUR ET GAZ D'ÉCHAPPEMENT (MODELE BOITE MANUELLE DU G16B, J20A MOTEUR)
SISTEMA DE ENCENDIDO, MOTOR Y CONTROL DE EMISIONES (MODELO DE TRANSMISIÓN MANUAL DEL MODELO DE MOTOR G16B, J20A)

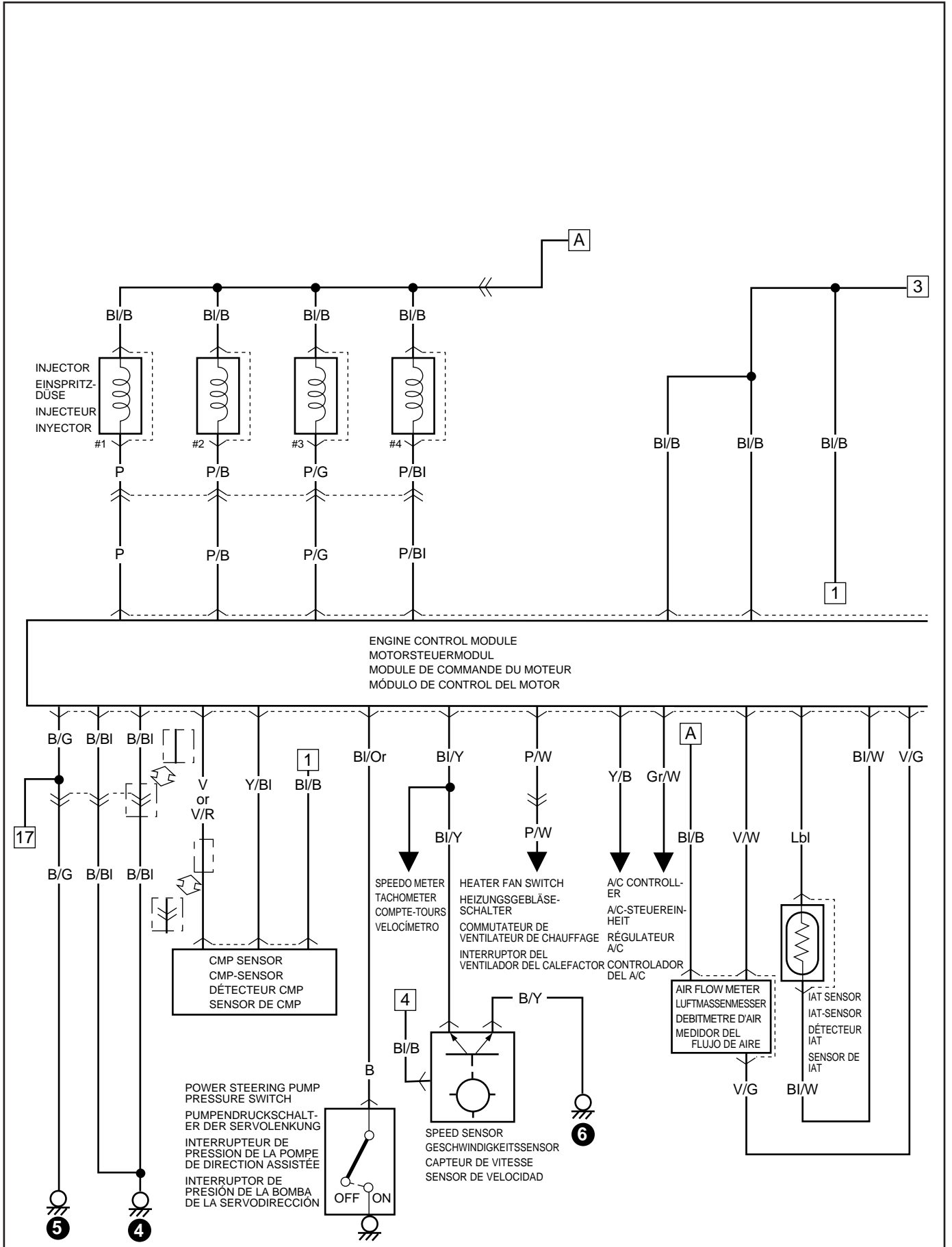

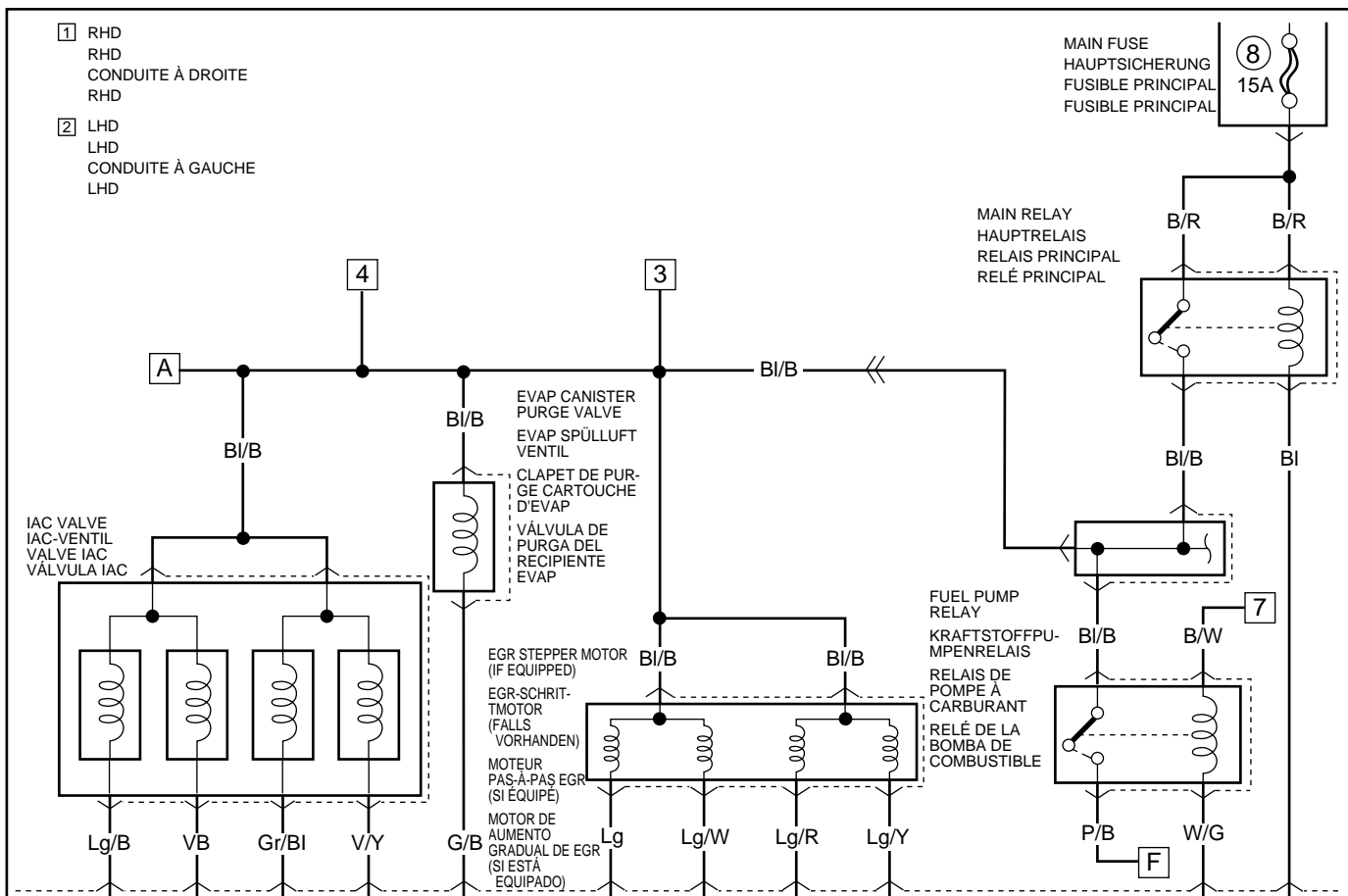

ENGINE CONTROL MODULE
 MOTORSTEUERMODUL
 MODULE DE COMMANDE DU MOTEUR
 MÓDULO DE CONTROL DEL MOTOR

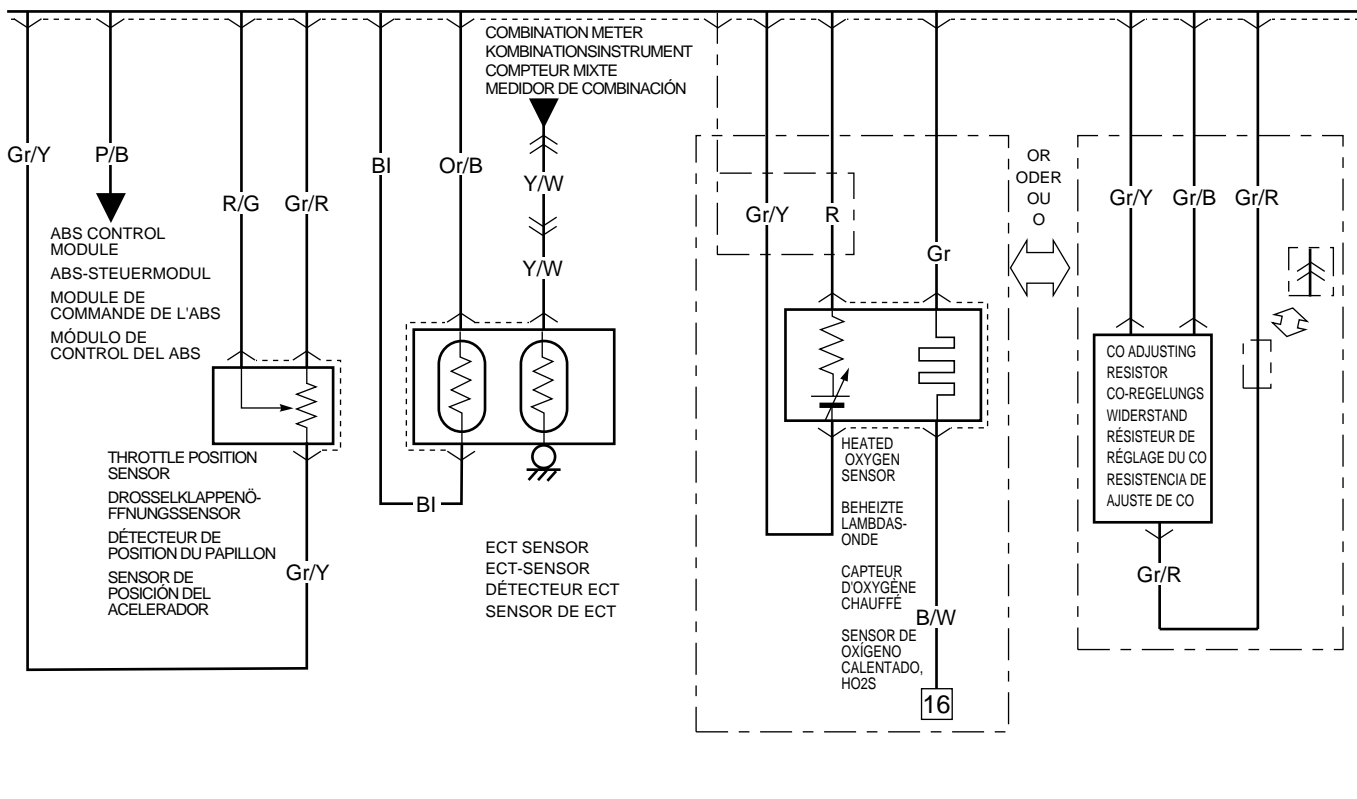

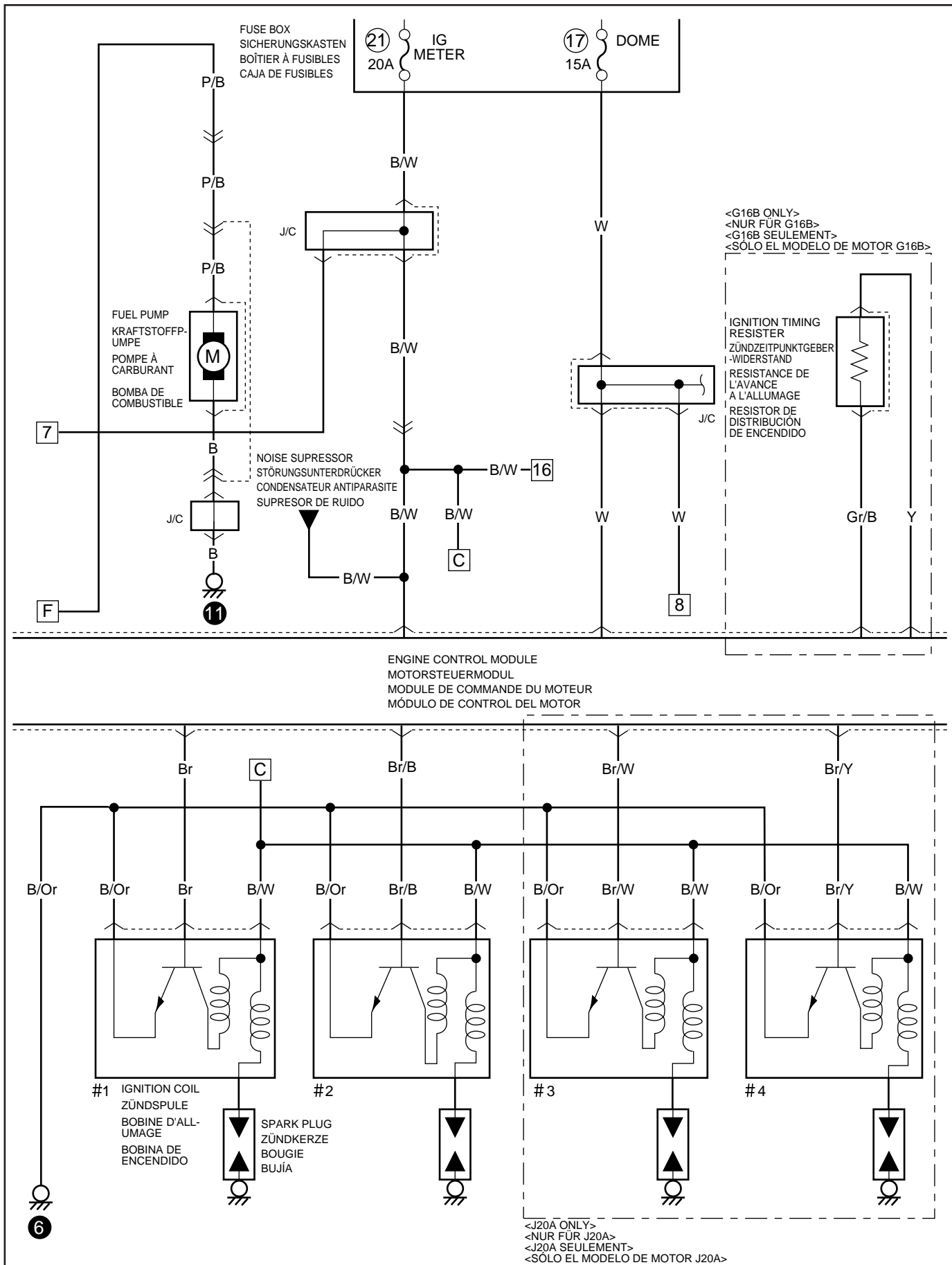

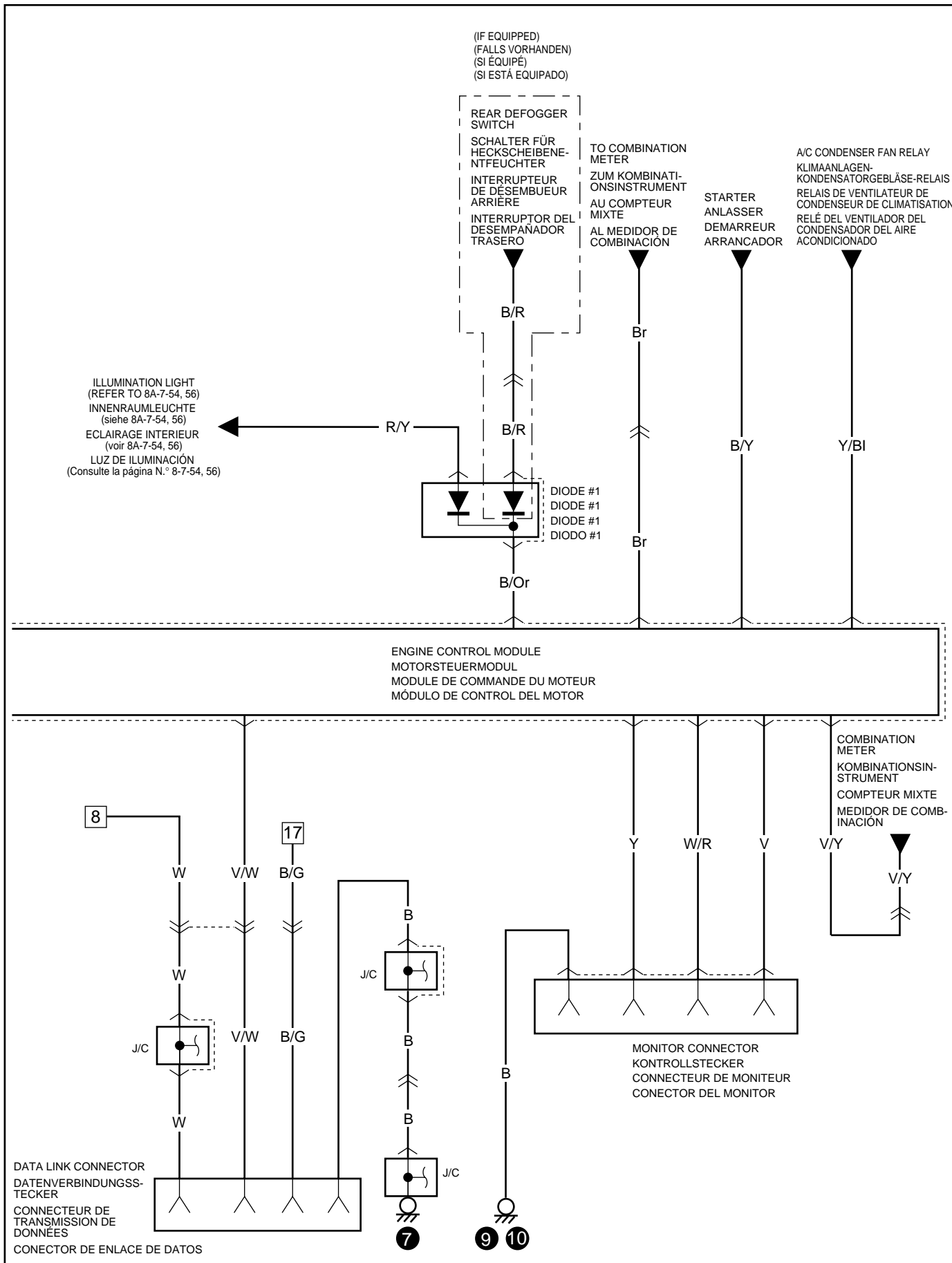

IGNITION, ENGINE & EMISSION & A/T CONTROL SYSTEM (A/T MODEL OF G16B, J20A ENGINE)

ZÜNDUNG, MOTOR UND ABGASE UND AUTOMATIKGETRIEBESTEUERSYSTEM (AUTOMATIKGETRIEBEVERSION VON G16B, J20A MOTOR)

SYSTEME DE COMMANDE DE L'ALLUMAGE, MOTEUR, GAZ D'ÉCHAPPEMENT ET BOÎTE AUTOMATIQUE (MODELE BOÎTE AUTOMATIQUE DU G16B, J20A MOTEUR)

SISTEMA DE CONTROL DE ENCENDIDO, MOTOR, EMISIONES Y TRANSMISIÓN AUTOMÁTICA (MODELO DE TRANSMISIÓN AUTOMÁTICA DEL MODELO DE MOTOR G16B, J20A)

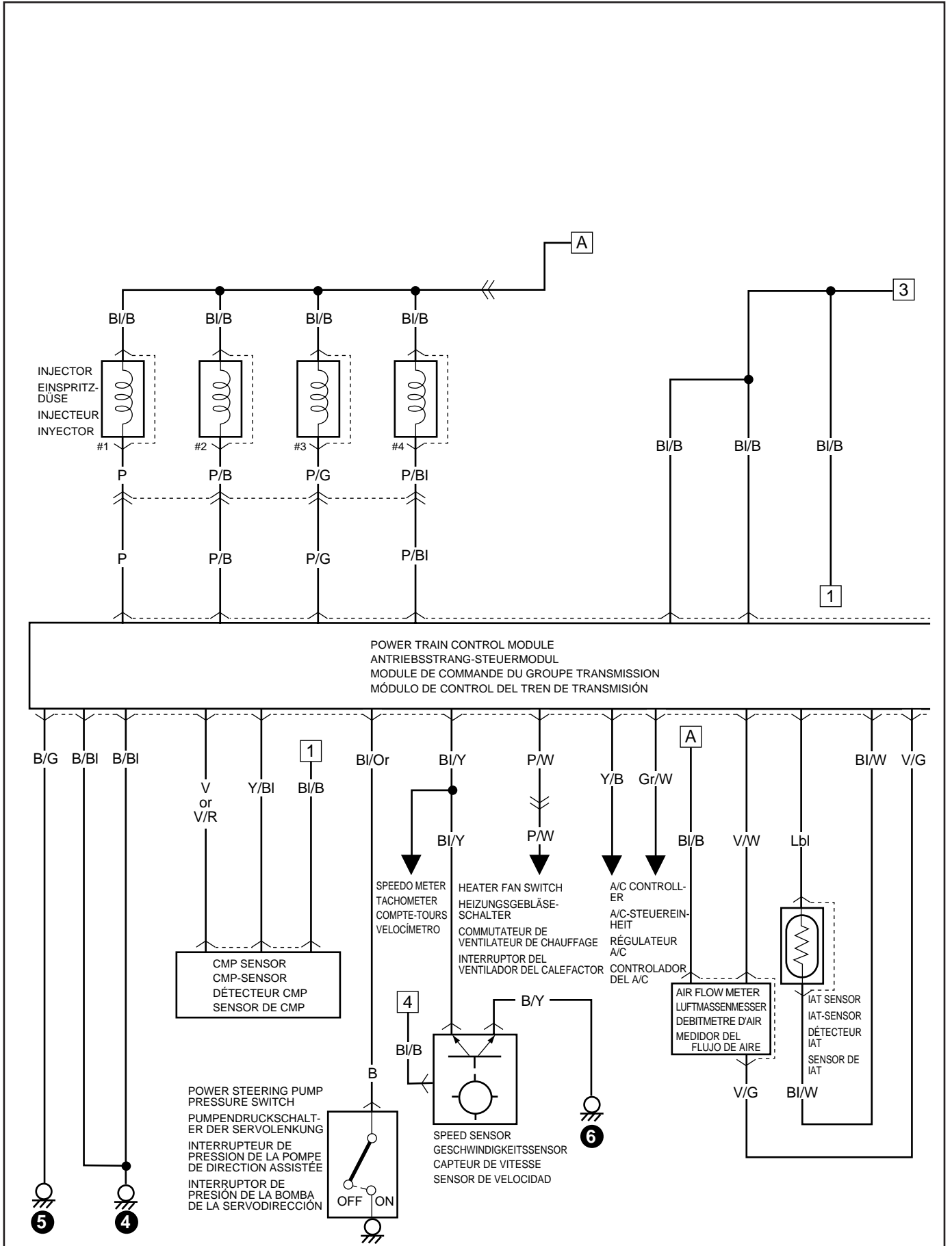

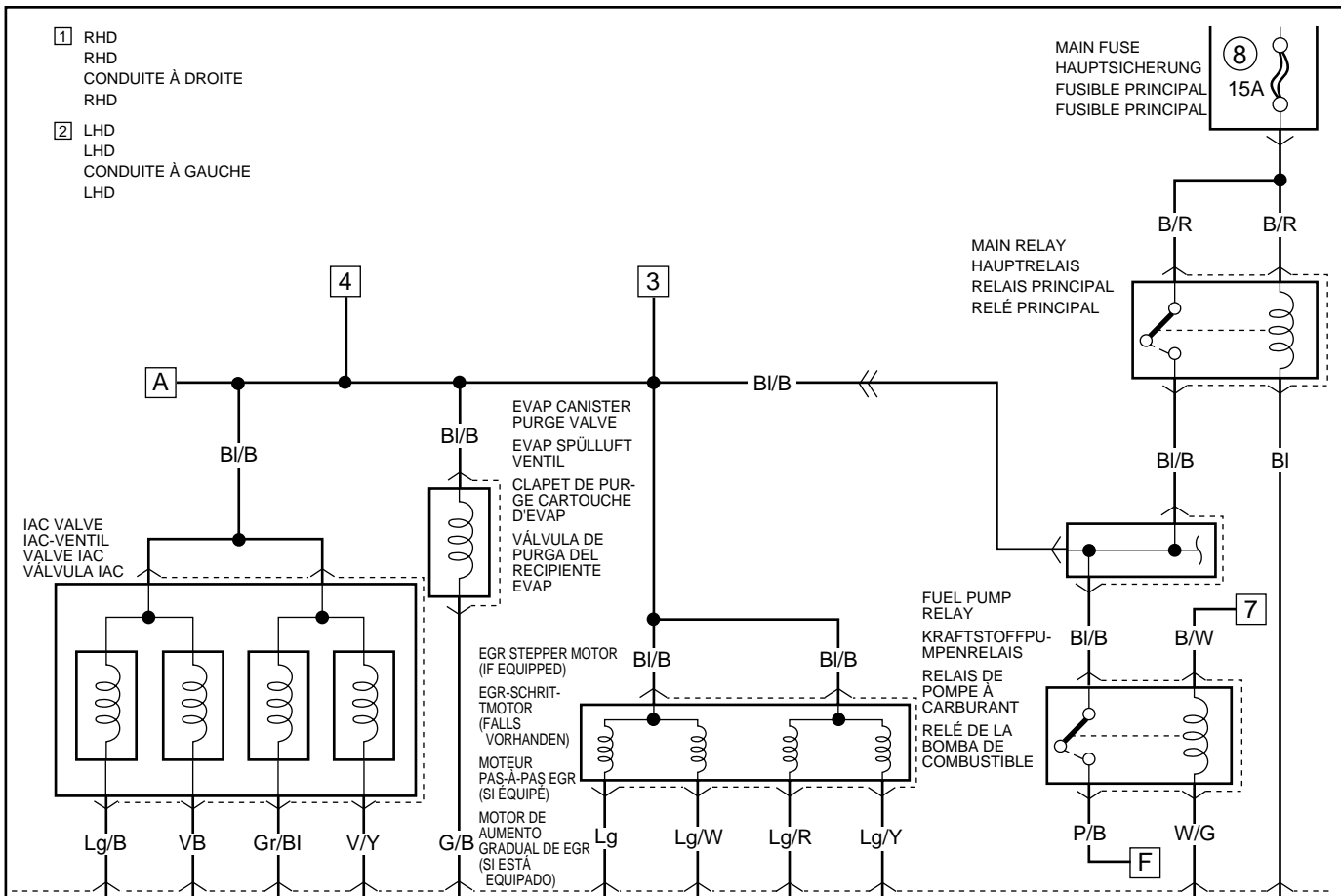

POWER TRAIN CONTROL MODULE
 ANTRIEBSSTRANG-STEUERMODUL
 MODULE DE COMMANDE DU GROUPE TRANSMISSION
 MÓDULO DE CONTROL DEL TREN DE TRANSMISIÓN

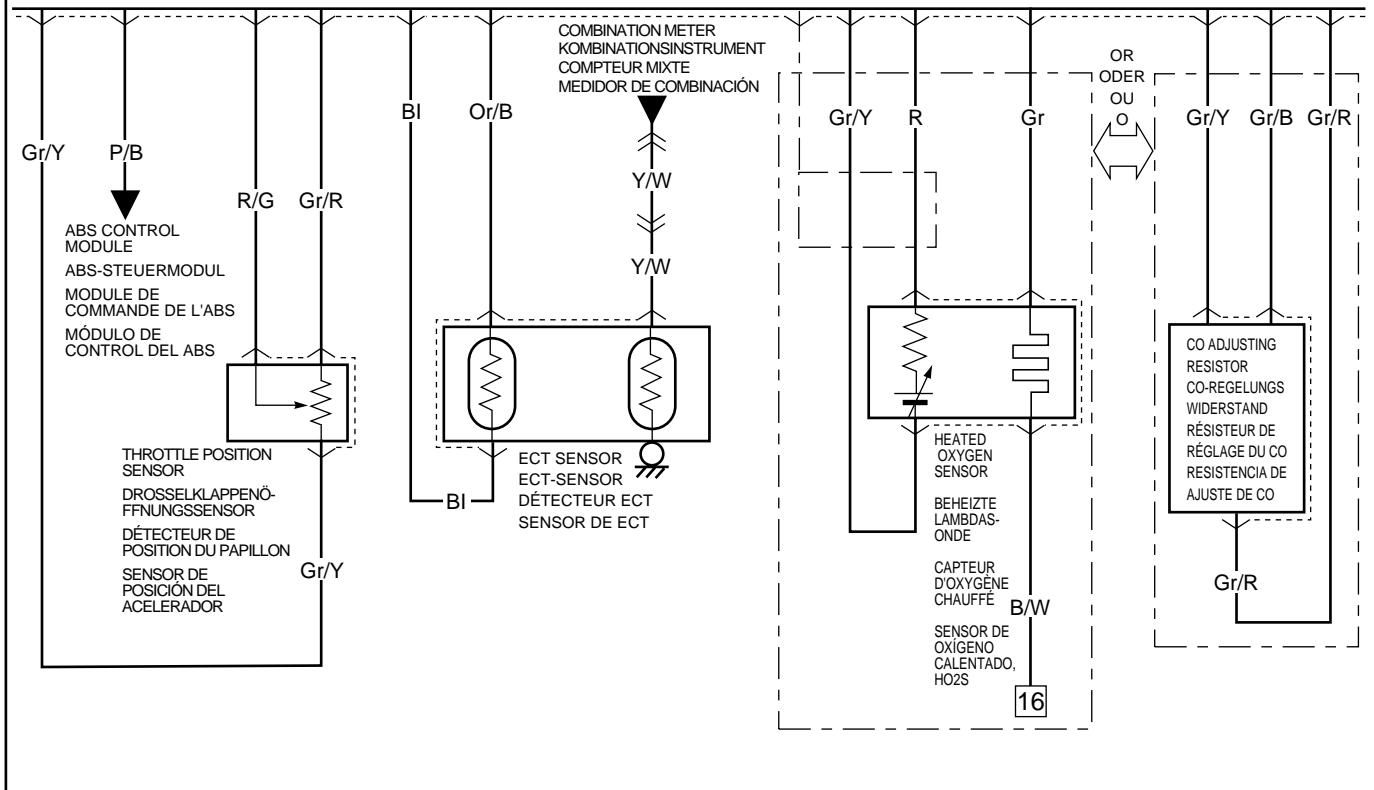

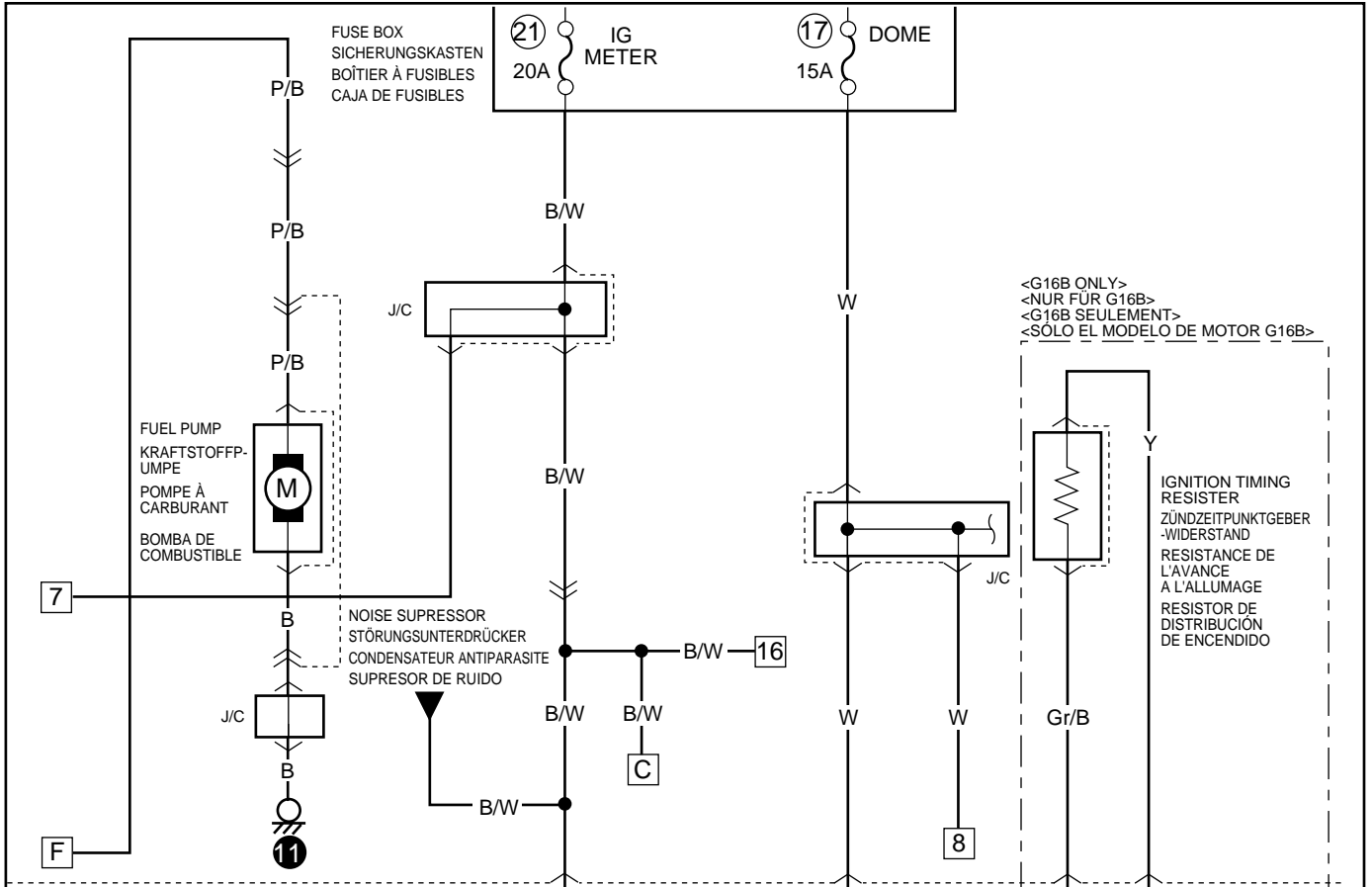

POWER TRAIN CONTROL MODULE
 ANTRIEBSSTRANG-STEUERMODUL
 MODULE DE COMMANDE DU GROUPE TRANSMISSION
 MÓDULO DE CONTROL DEL TREN DE TRANSMISIÓN

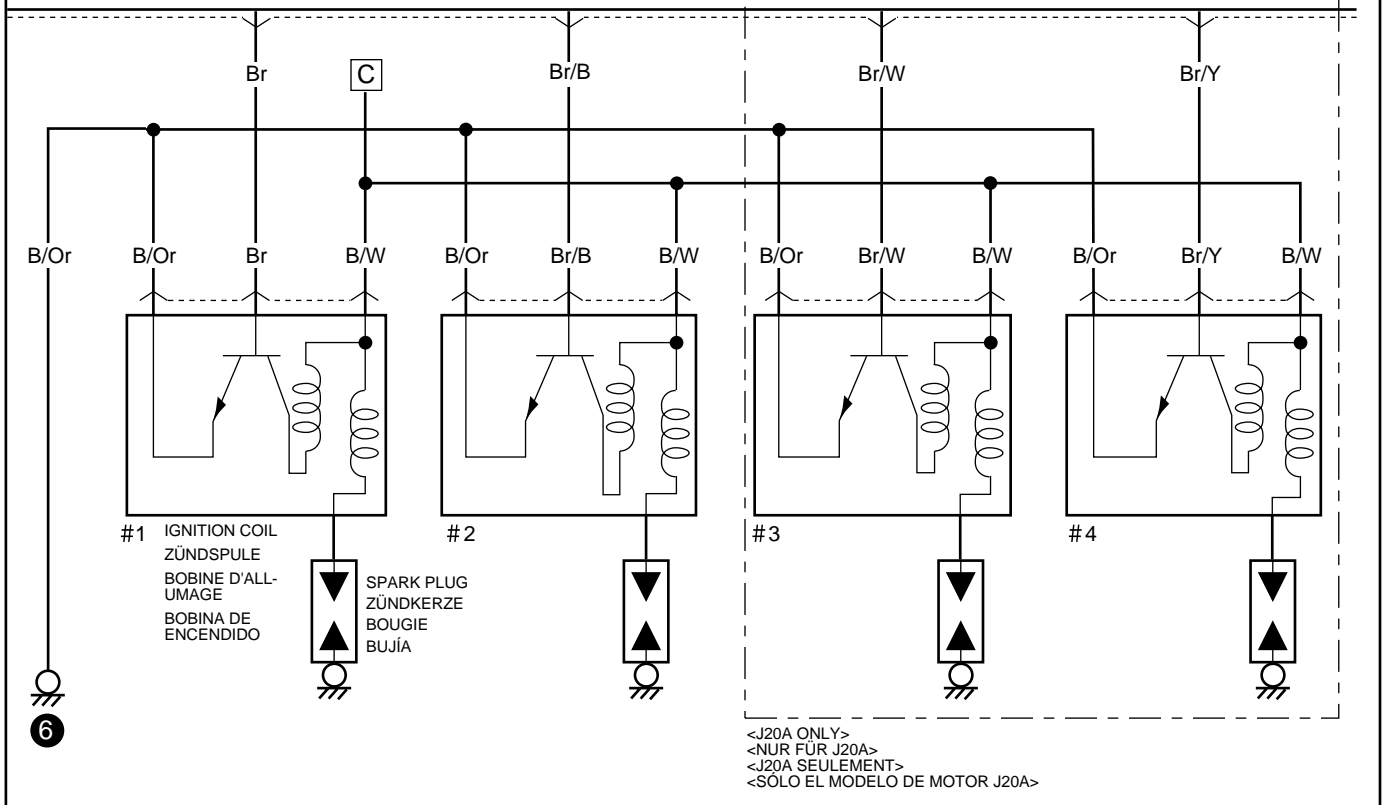

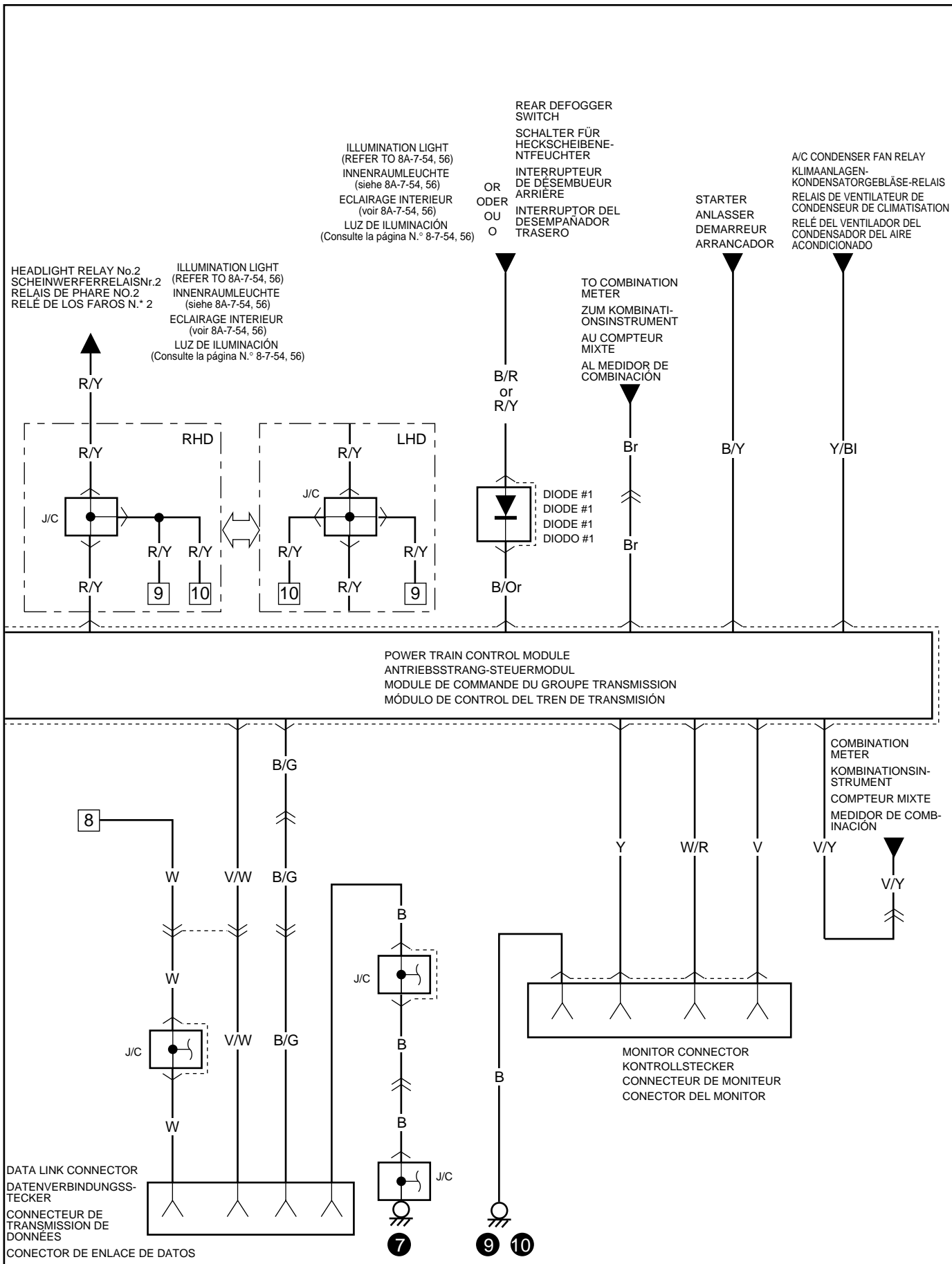

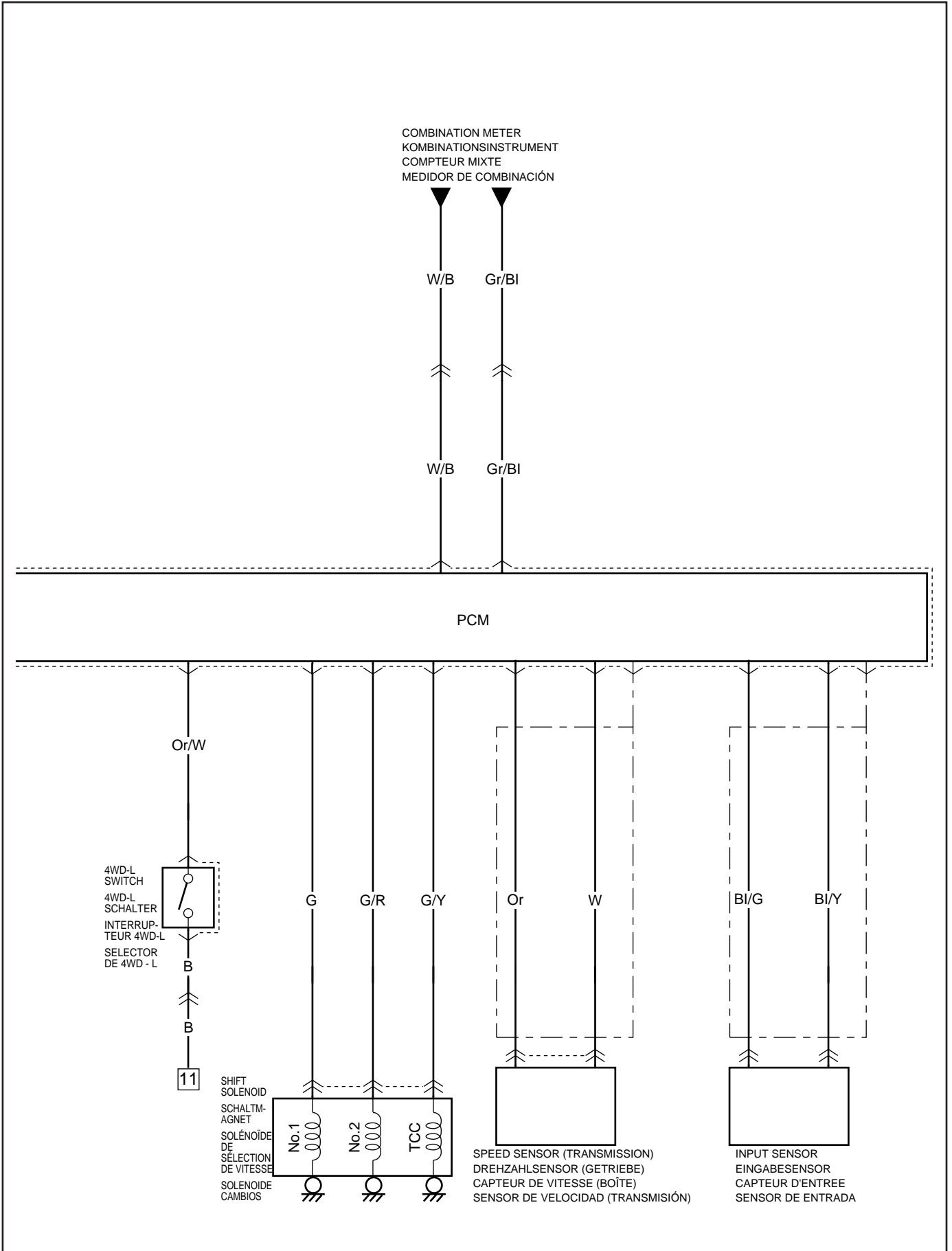

IGNITION, ENGINE & EMISSION CONTROL SYSTEM (M/T MODEL OF H25A ENGINE)
ZÜNDUNGS-, MOTOR- UND ABGASREGELSYSTEM (SCHALTGETRIEBEVERSION VON H25A MOTOR)
SYSTEME DE COMMANDE DE L'ALLUMAGE, MOTEUR ET GAZ D'ÉCHAPPEMENT (MODELE BOITE MANUELLE DU H25A MOTEUR)
SISTEMA DE ENCENDIDO, MOTOR Y CONTROL DE EMISIONES (MODELO DE TRANSMISIÓN MANUAL DEL MODELO DE MOTOR H25A)

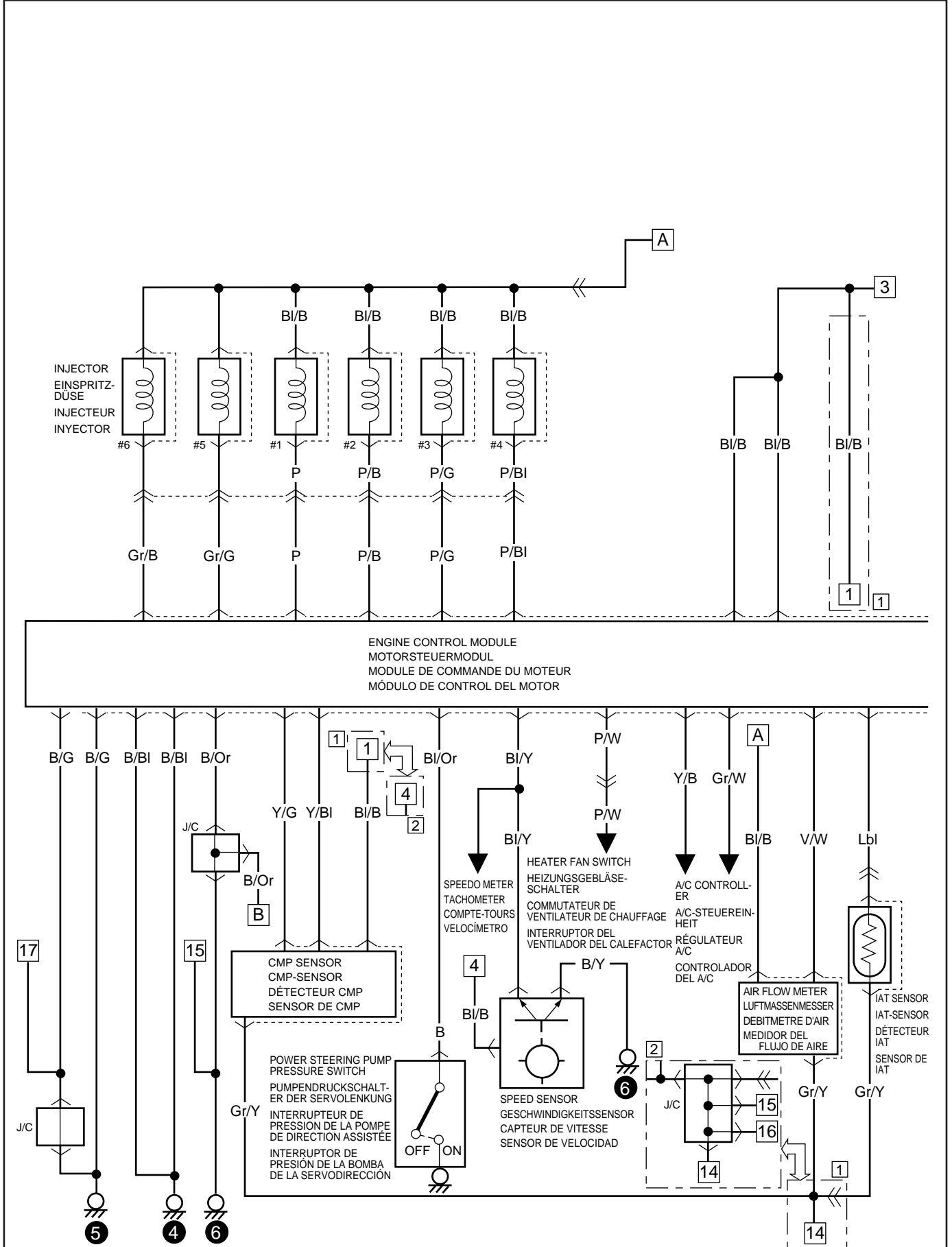

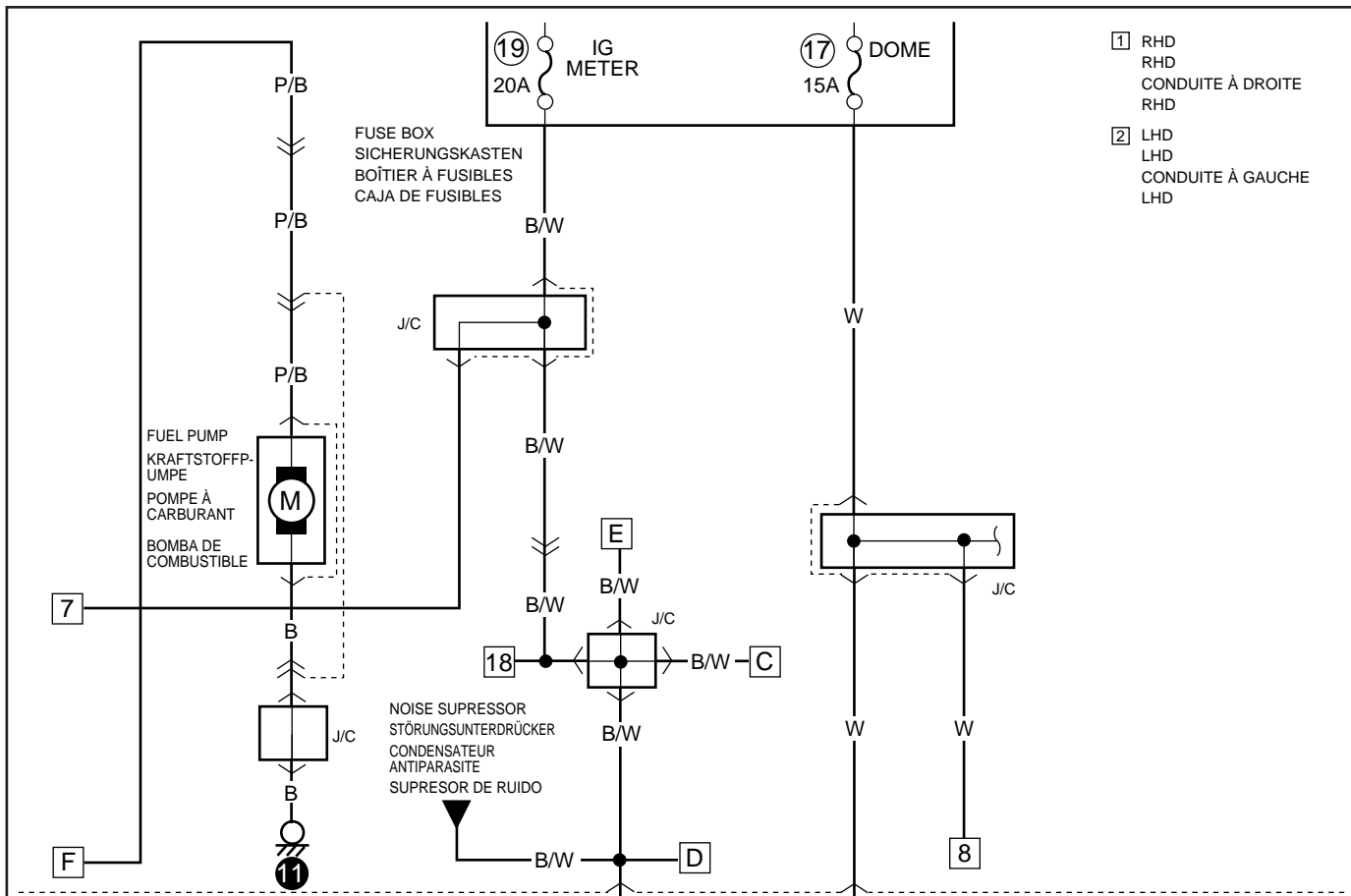

ENGINE CONTROL MODULE
 MOTORSTEUERMODUL
 MODULE DE COMMANDE DU MOTEUR
 MÓDULO DE CONTROL DEL MOTOR

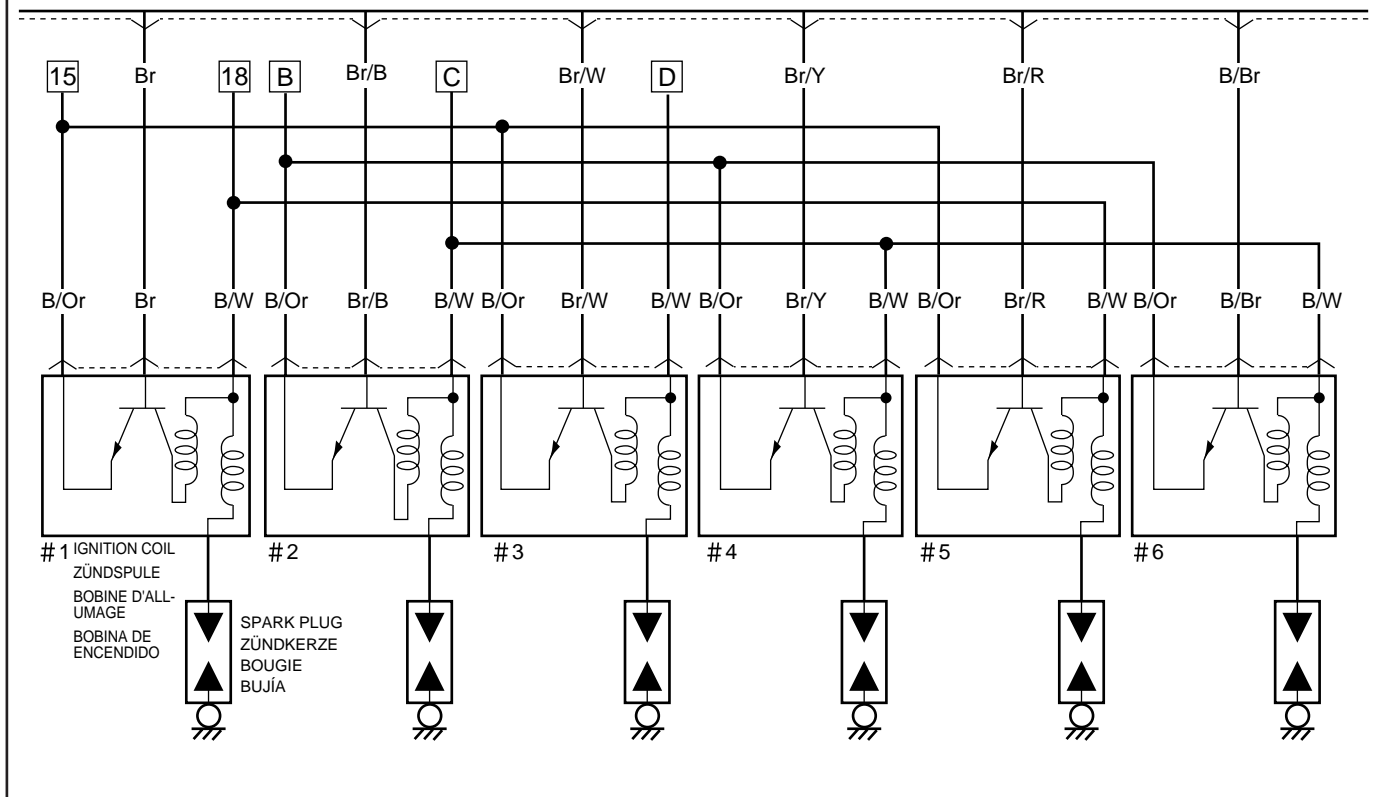

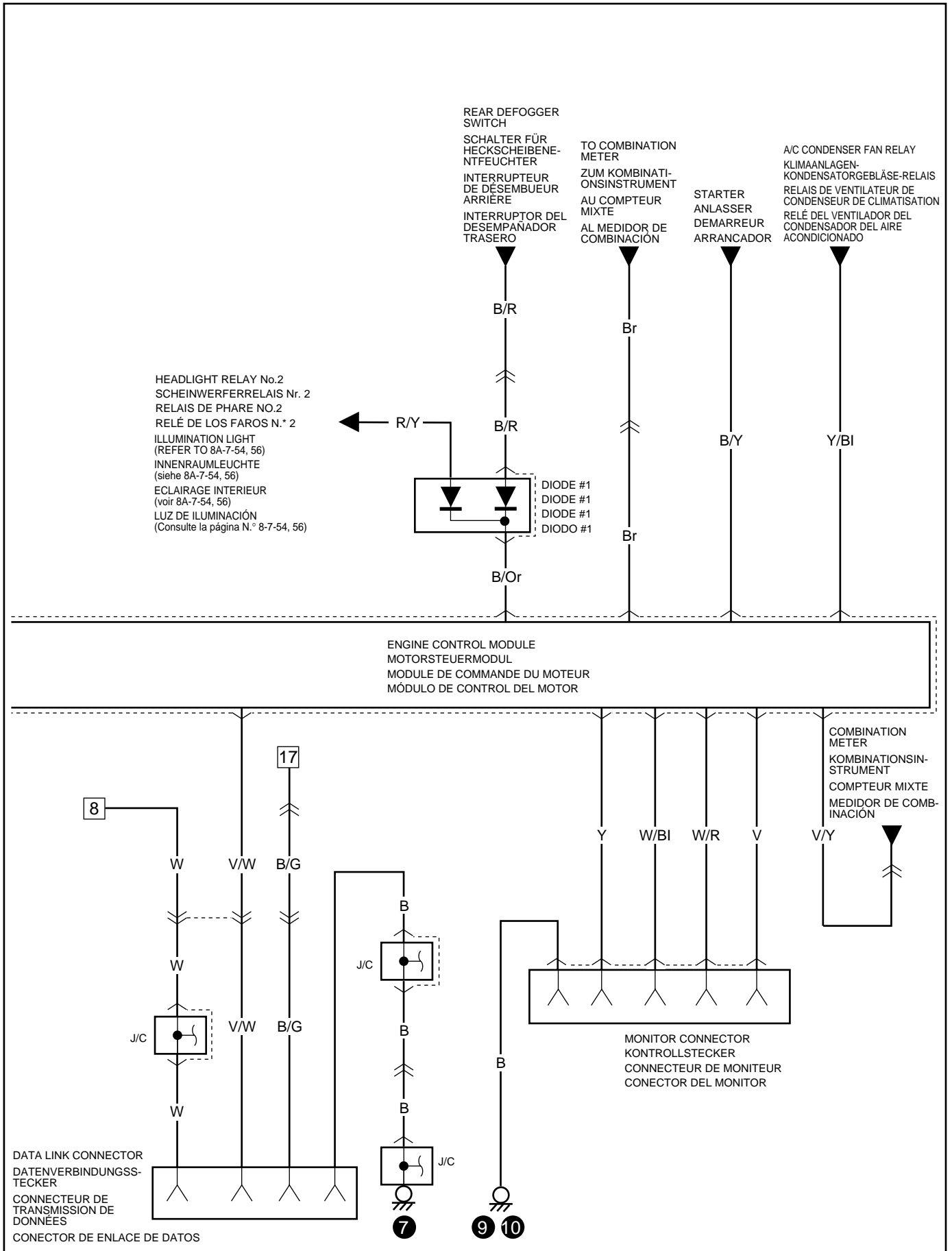

IGNITION, ENGINE & EMISSION & A/T CONTROL SYSTEM (A/T MODEL OF H25A ENGINE)

ZÜNDUNG, MOTOR UND ABGASE UND AUTOMATIKGETRIEBESTEUERSYSTEM (AUTOMATIKGETRIEBEVERSION VON H25A MOTOR)

SYSTEME DE COMMANDE DE L'ALLUMAGE, MOTEUR, GAZ D'ÉCHAPPEMENT ET BOÎTE AUTOMATIQUE (MODELE BOÎTE AUTOMATIQUE DU H25A MOTEUR)

SISTEMA DE CONTROL DE ENCENDIDO, MOTOR, EMISIONES Y TRANSMISIÓN AUTOMÁTICA (MODELO DE TRANSMISIÓN AUTOMÁTICA DEL MODELO DE MOTOR H25A)

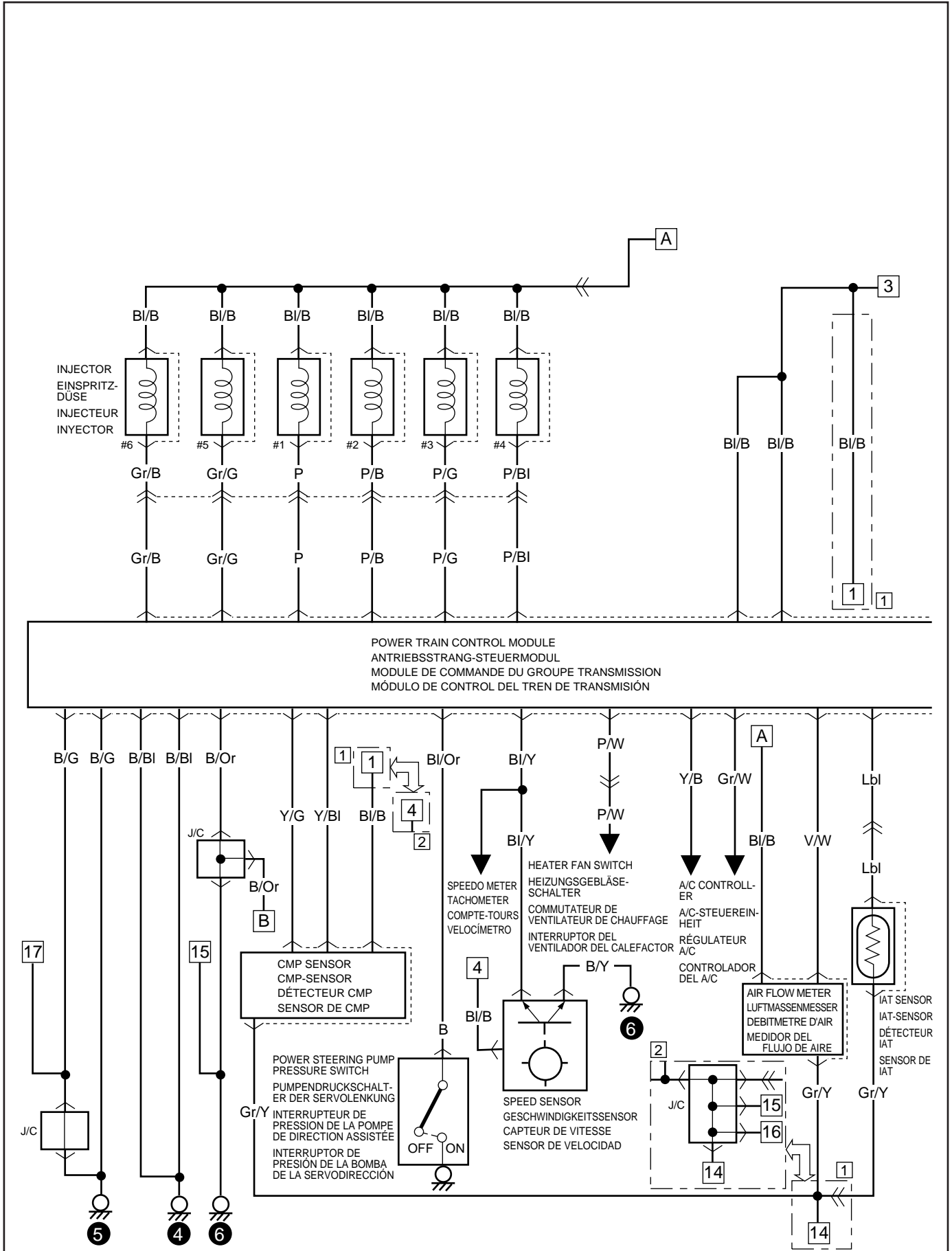

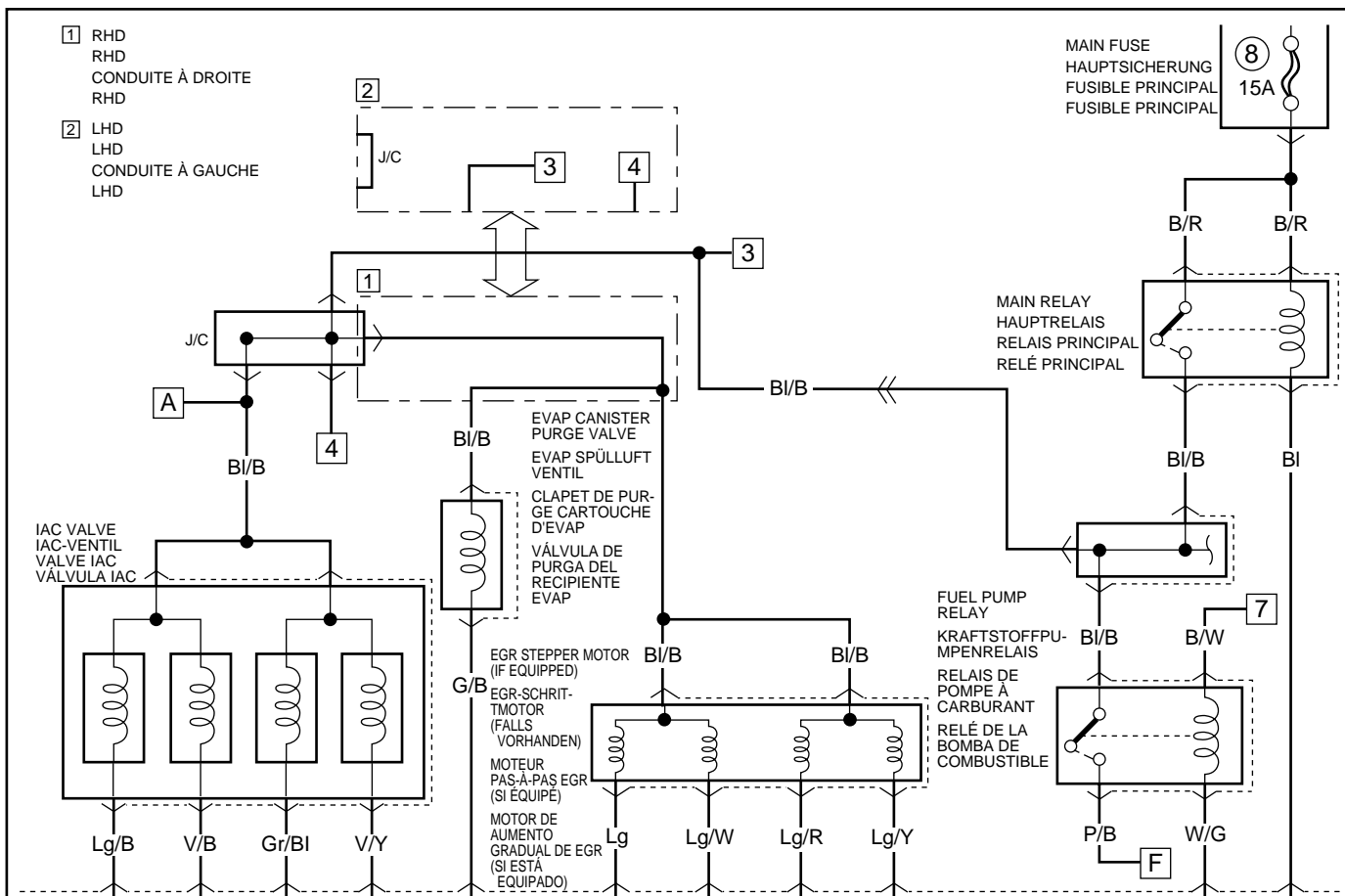

POWER TRAIN CONTROL MODULE
 ANTRIEBSSTRANG-STEUERMODUL
 MODULE DE COMMANDE DU GROUPE TRANSMISSION
 MÓDULO DE CONTROL DEL TREN DE TRANSMISIÓN

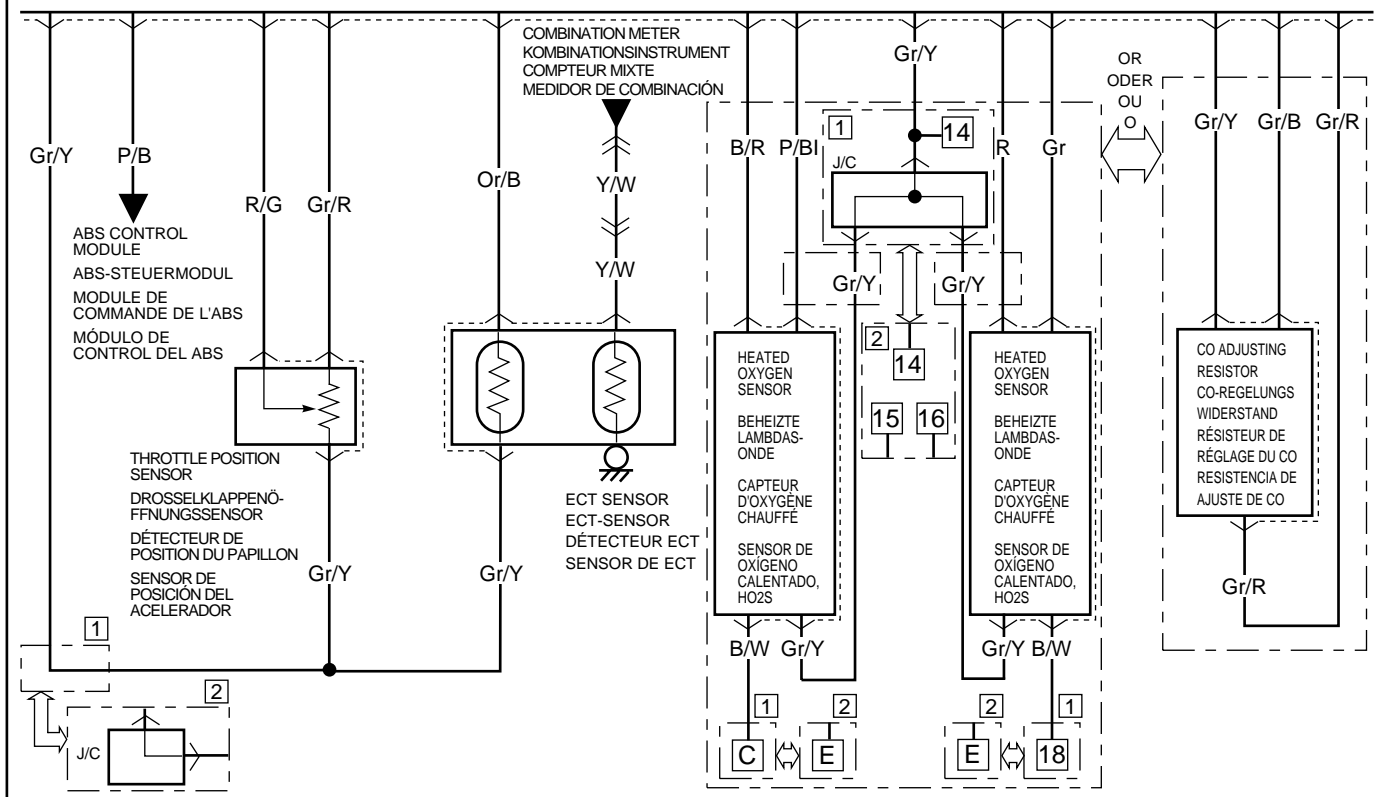

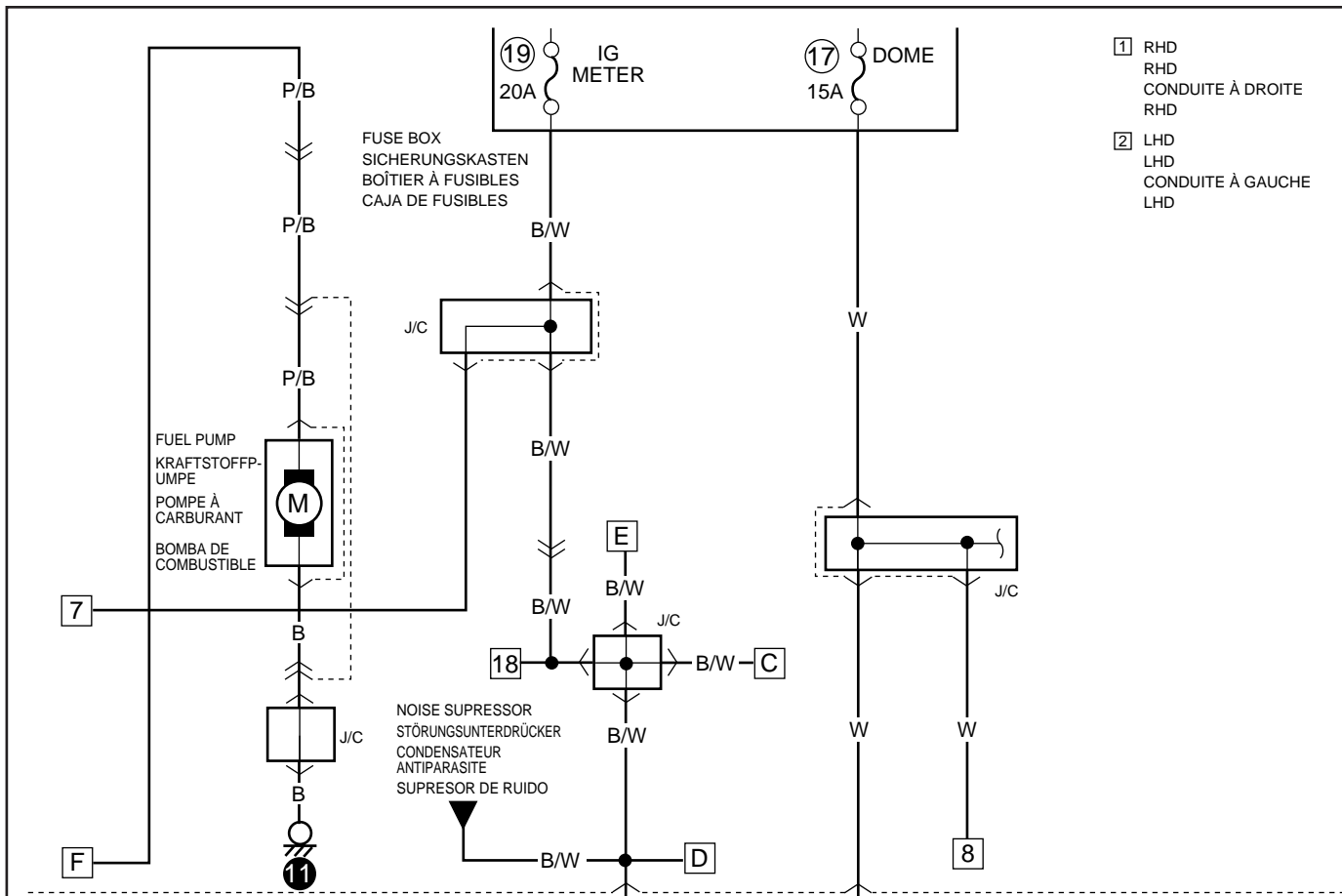

- ① RHD
 RHD
 CONDUITE À DROITE
 RHD
- ② LHD
 LHD
 CONDUITE À GAUCHE
 LHD

ENGINE CONTROL MODULE
 MOTORSTEUERMODUL
 MODULE DE COMMANDE DU MOTEUR
 MÓDULO DE CONTROL DEL MOTOR

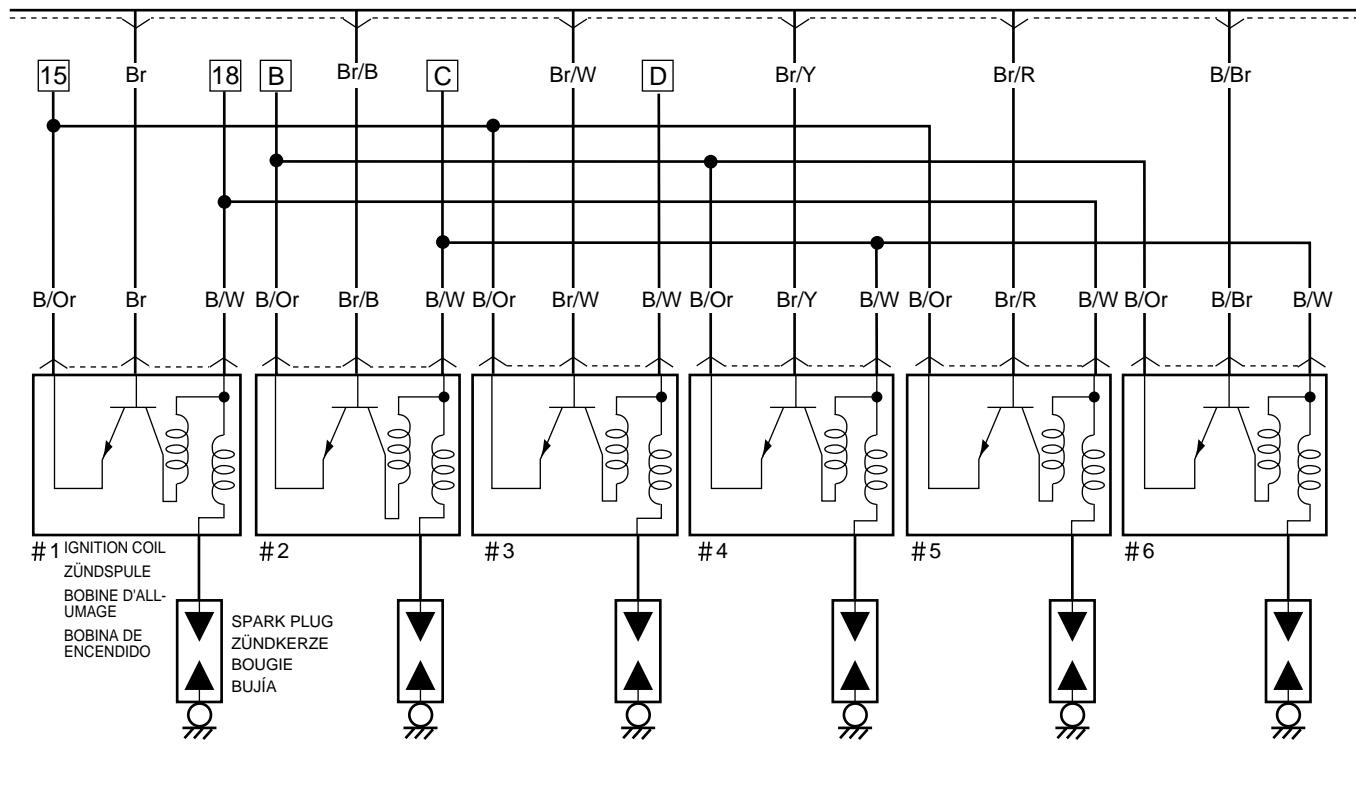

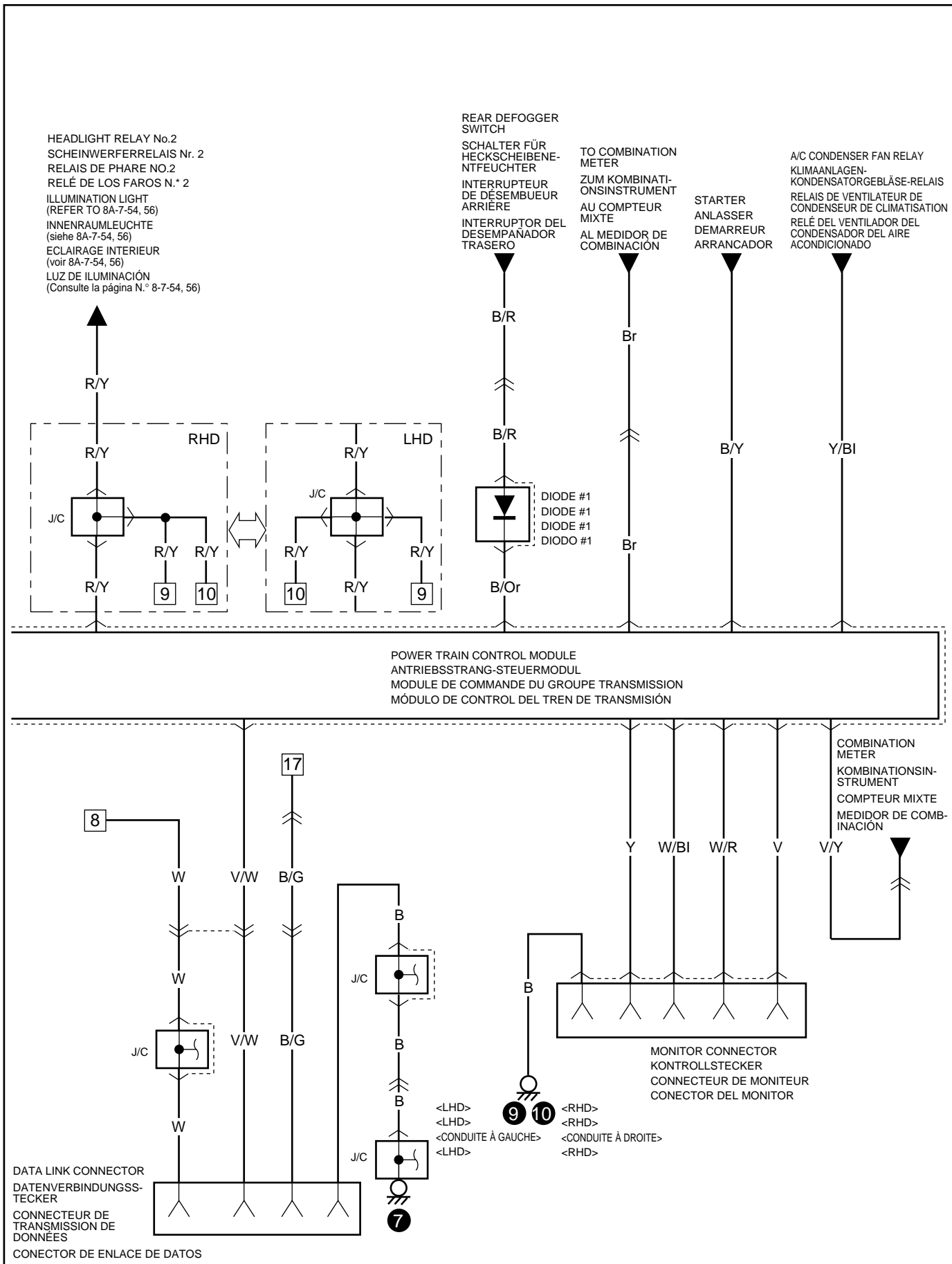

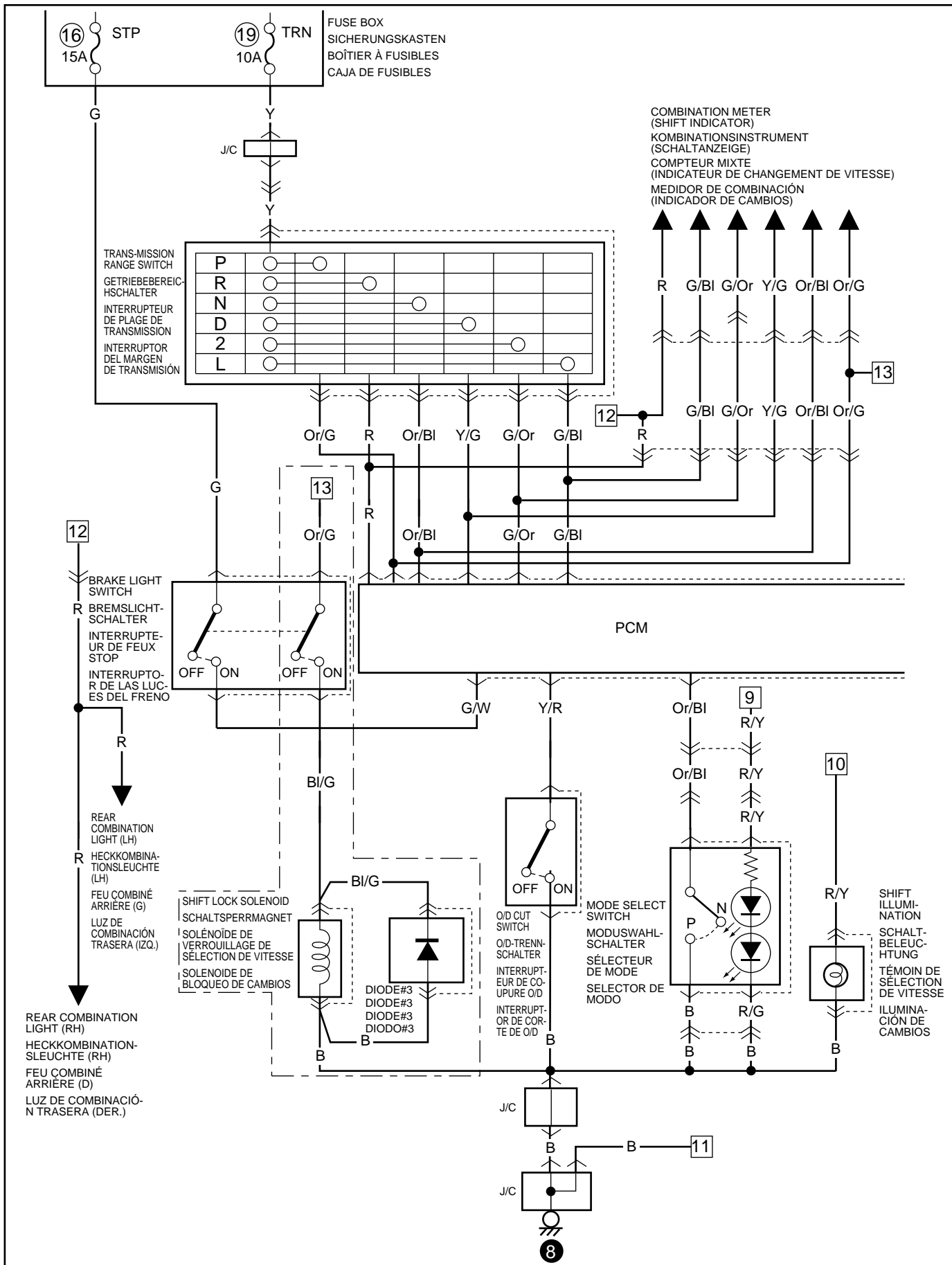

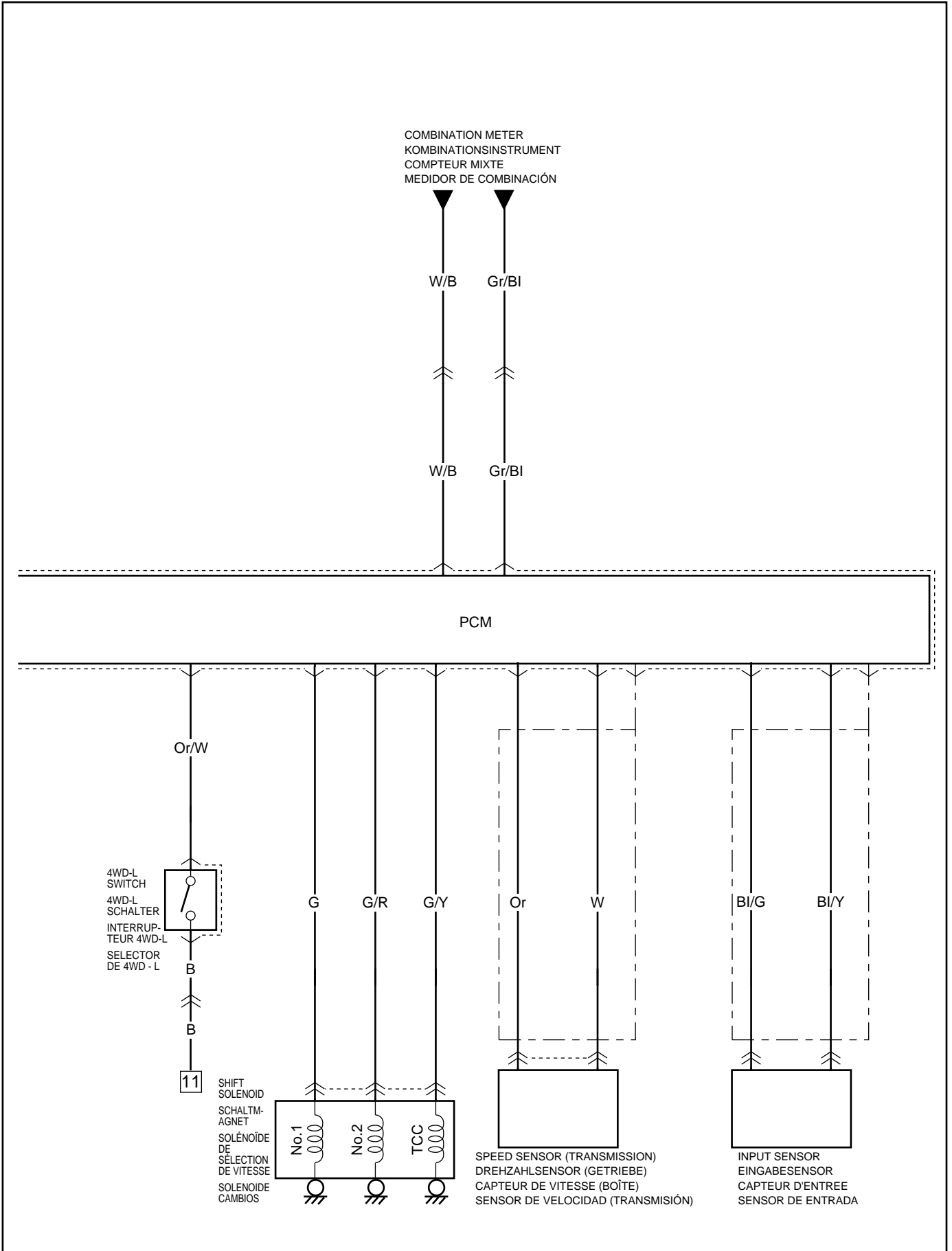

4WD CONTROL SYSTEM

4WD STEUERSYSTEM

SYSTEME DE COMMANDE 4WD

SISTEMA DE CONTROL DE TRACCIÓN EN LAS CUATRO RUEDAS

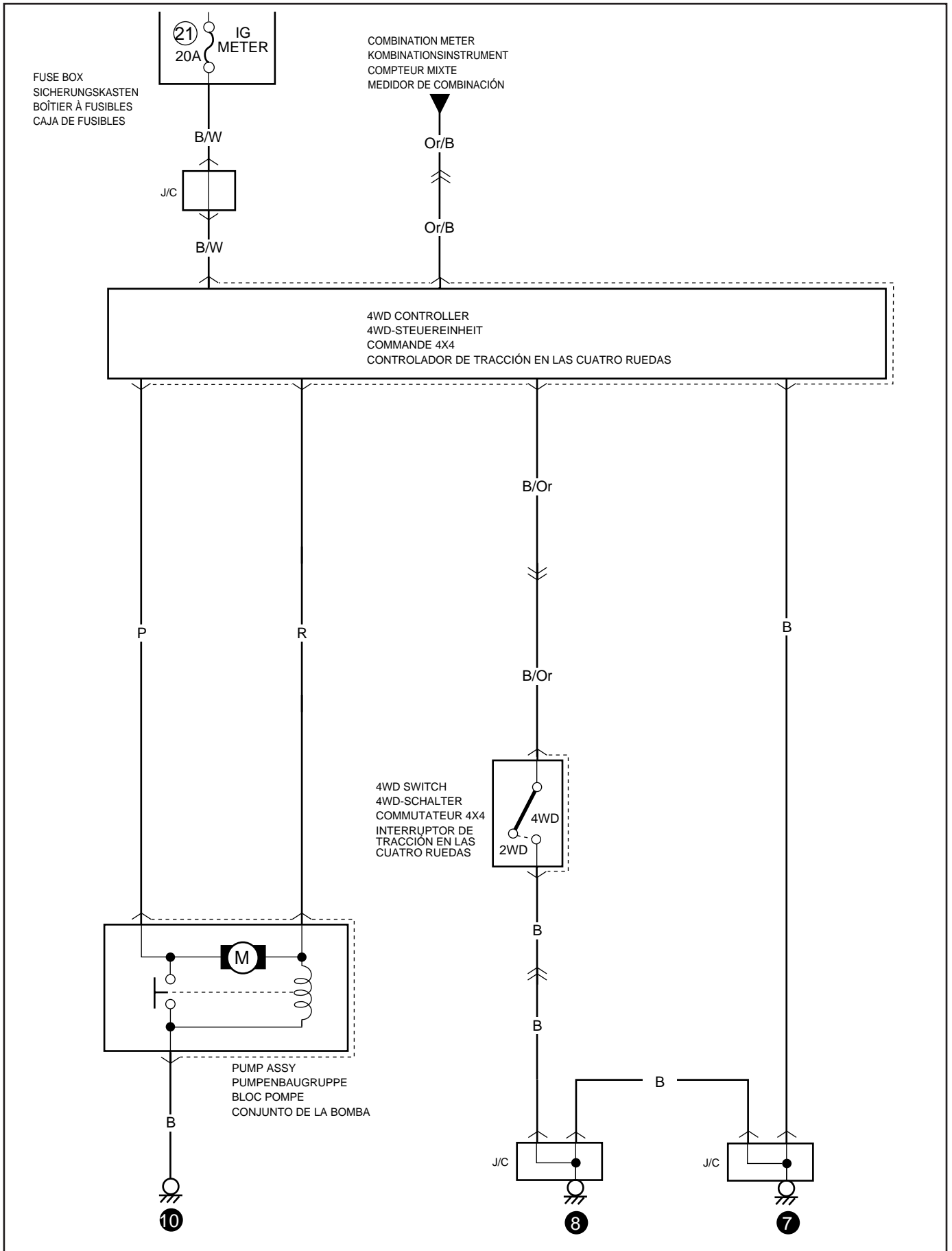

SLIDING ROOF
 TOIT OUVRANT
 SCHIEBEDACH
 TECHO DESLIZANTE

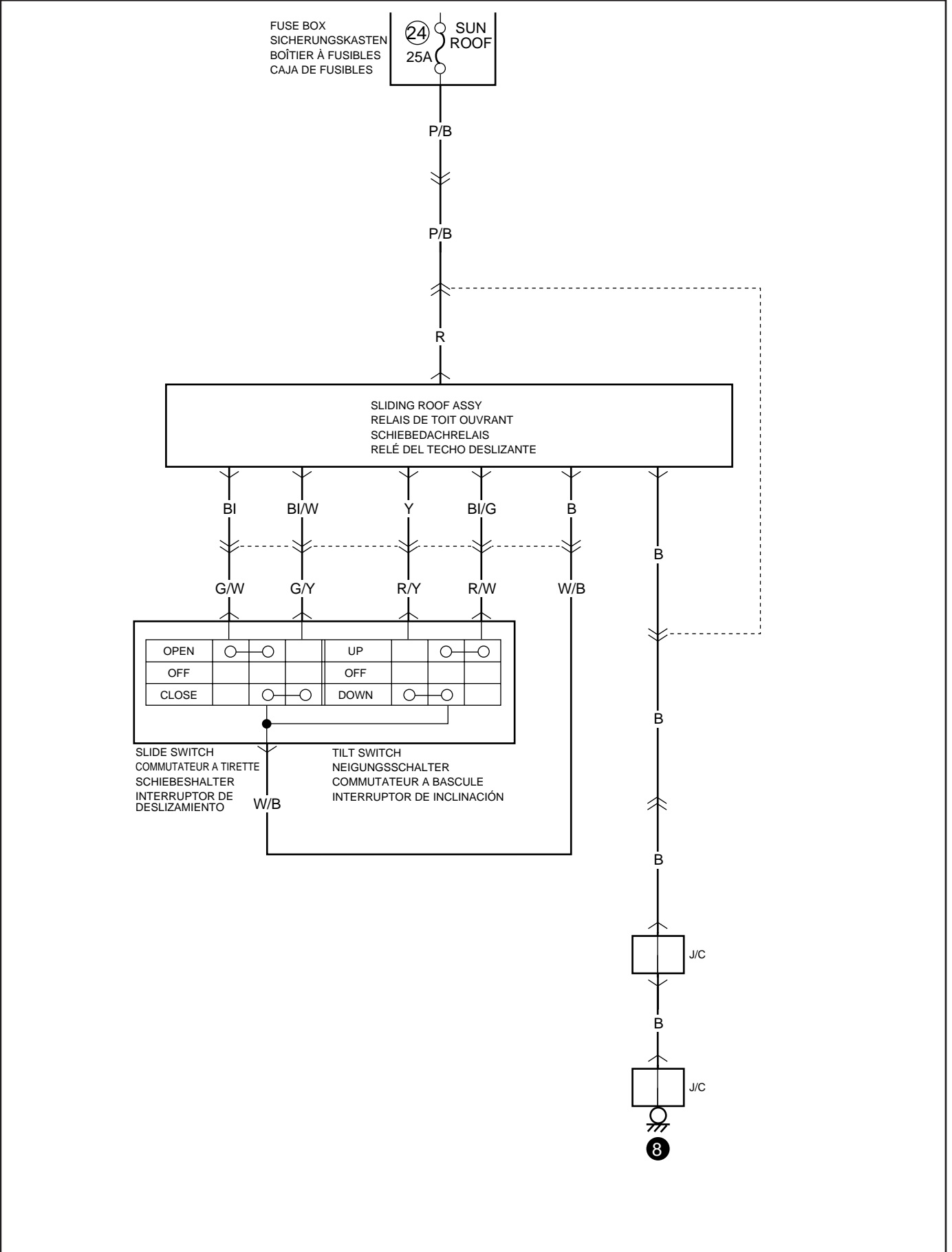

WINDSHIELD WIPER & WASHER
FRONTSCHWEIBENWISCHER UND WASCHANLAGE
ESSUIE-GLACE ET LAVE-GLACE DE PARE-BRISE
LIMPIADOR Y LAVADOR DEL PARABRISAS

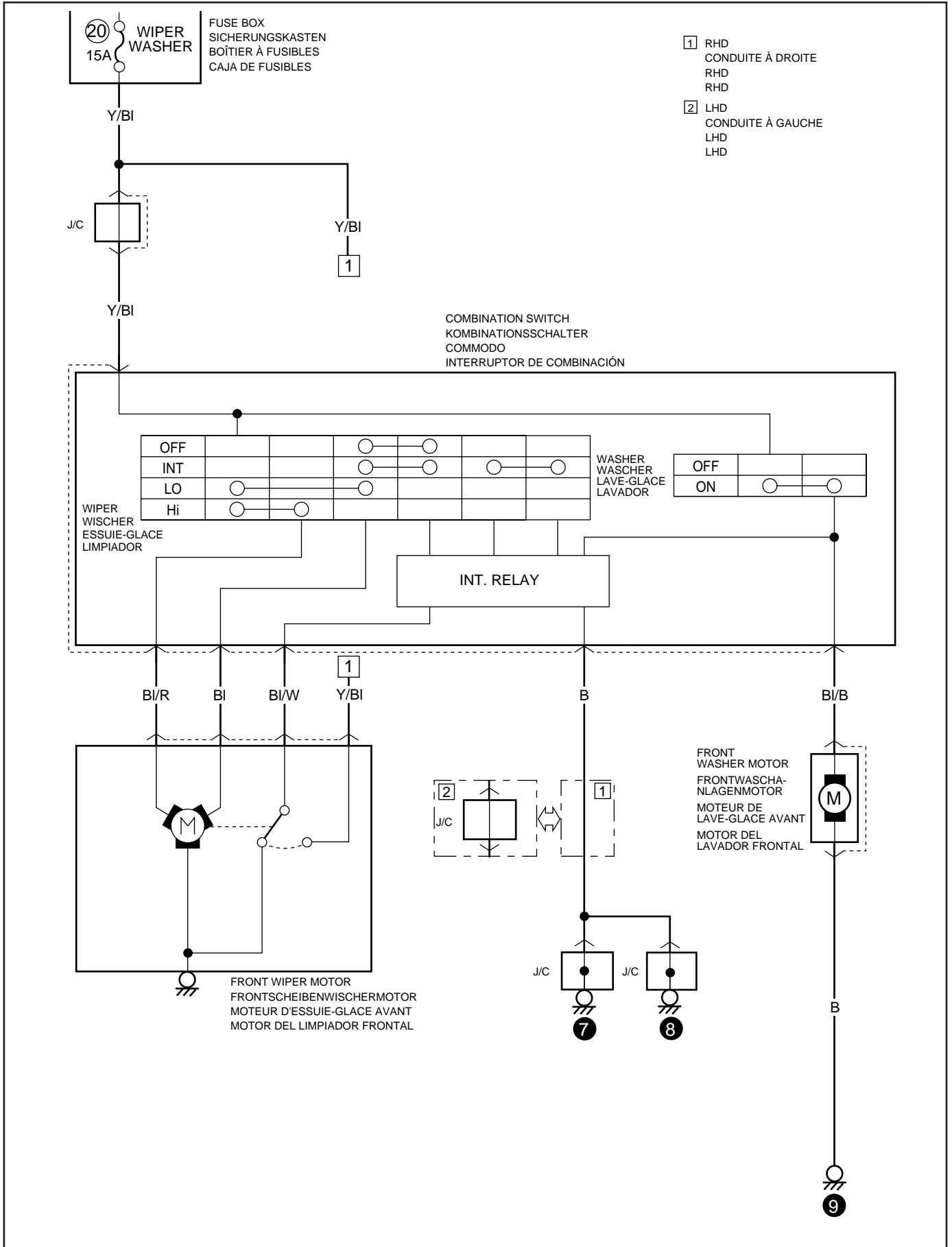

REAR WIPER & WASHER
HECKSCHWEIBENWISCHER UND WASCHANLAGE
ESSUIE-GLACE ET LAVE-GLACE ARRIÈRE
LIMPIADOR Y LAVADOR TRASERO

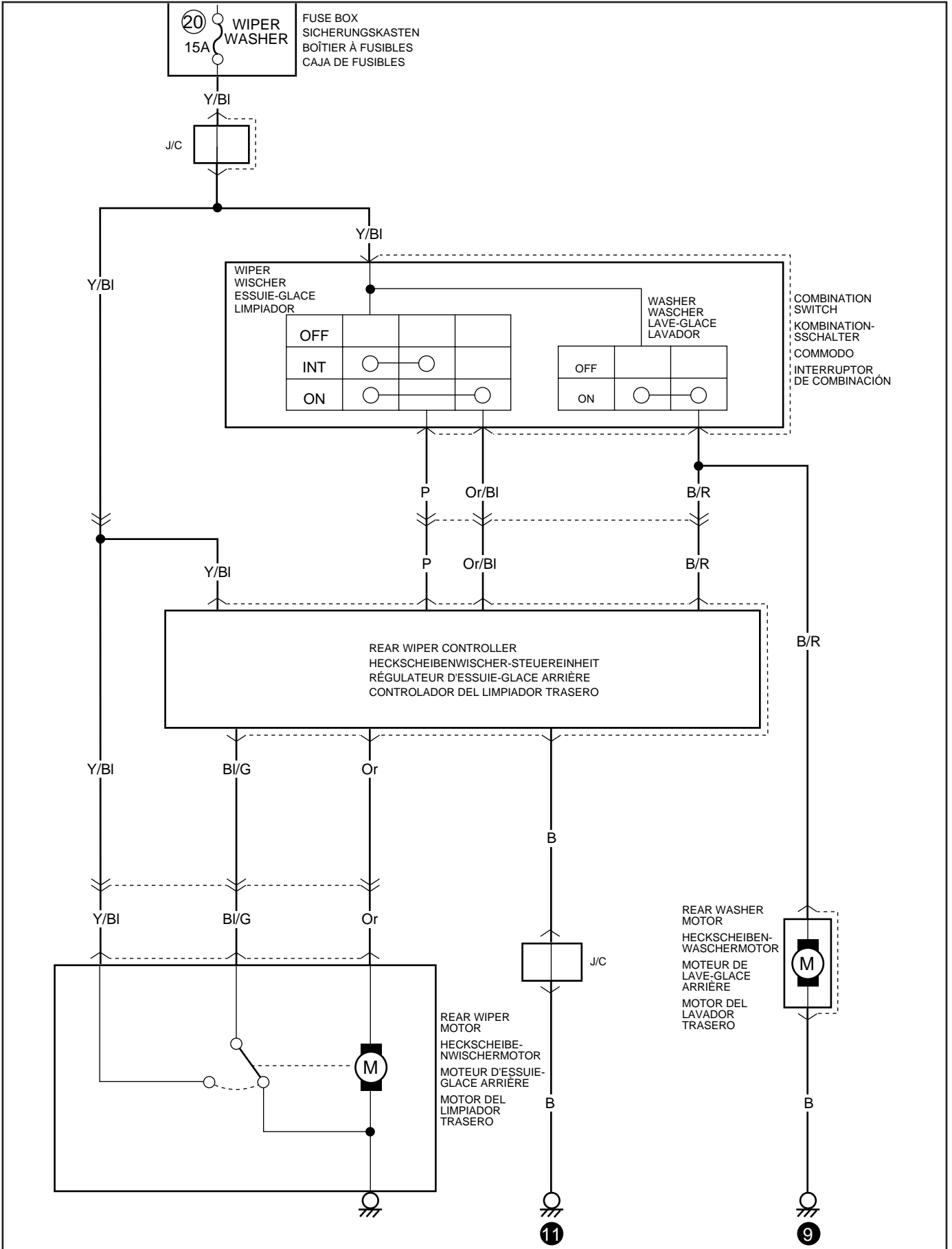

REAR WINDOW DEFOGGER
HECKSCHEIBENENTFEUCHTER
DÉSEMBUEUR DE FENÊTRE ARRIÈRE
DESEMPAÑADOR DE LA VENTANILLA TRASERA

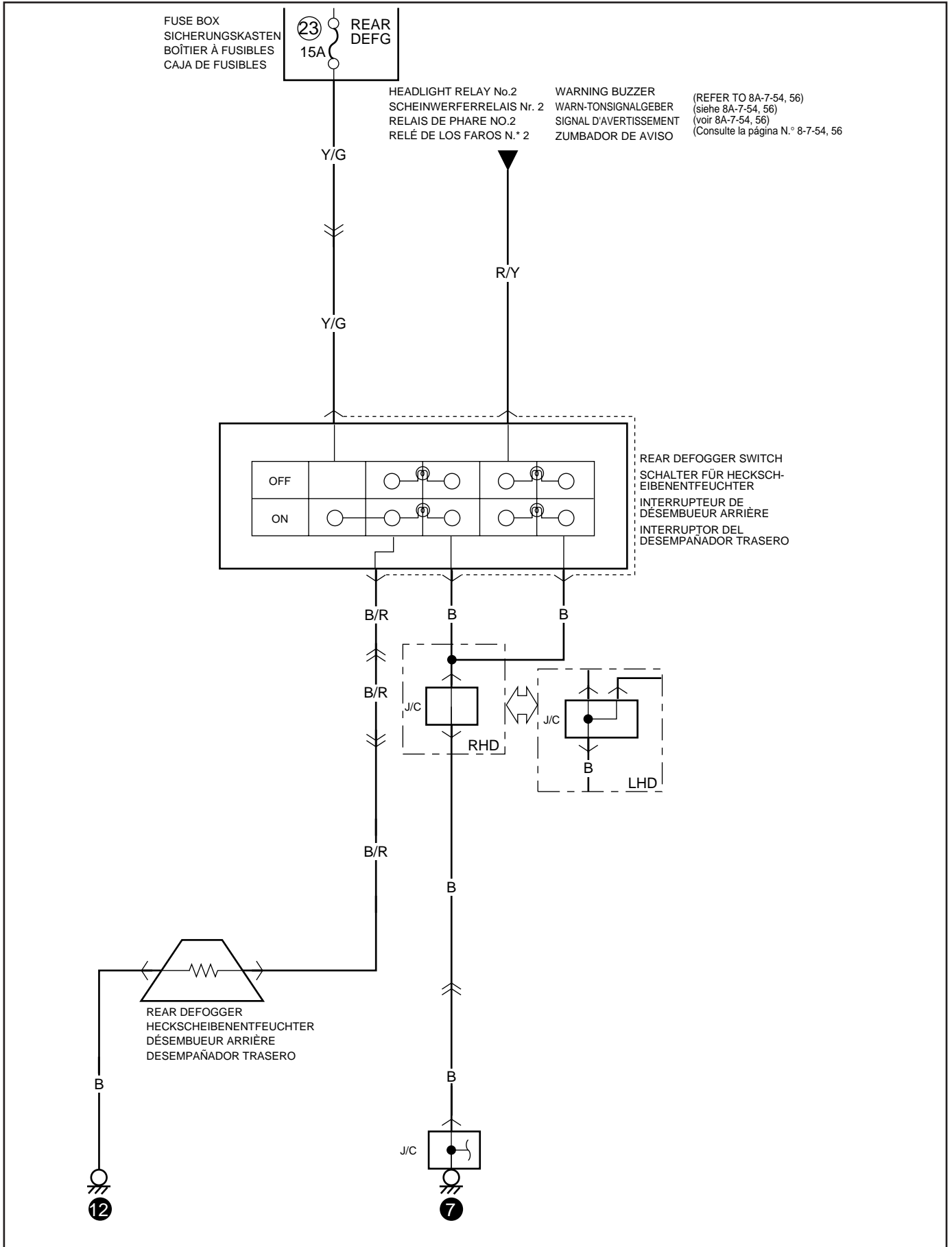

MEMO
NOTIZEN
NOTE
NOTAS

POWER WINDOW
AUTOMATISCHER FENSTERHEBER
LÈVE-VITRES ÉLECTRIQUES
VENTANILLA AUTOMÁTICA

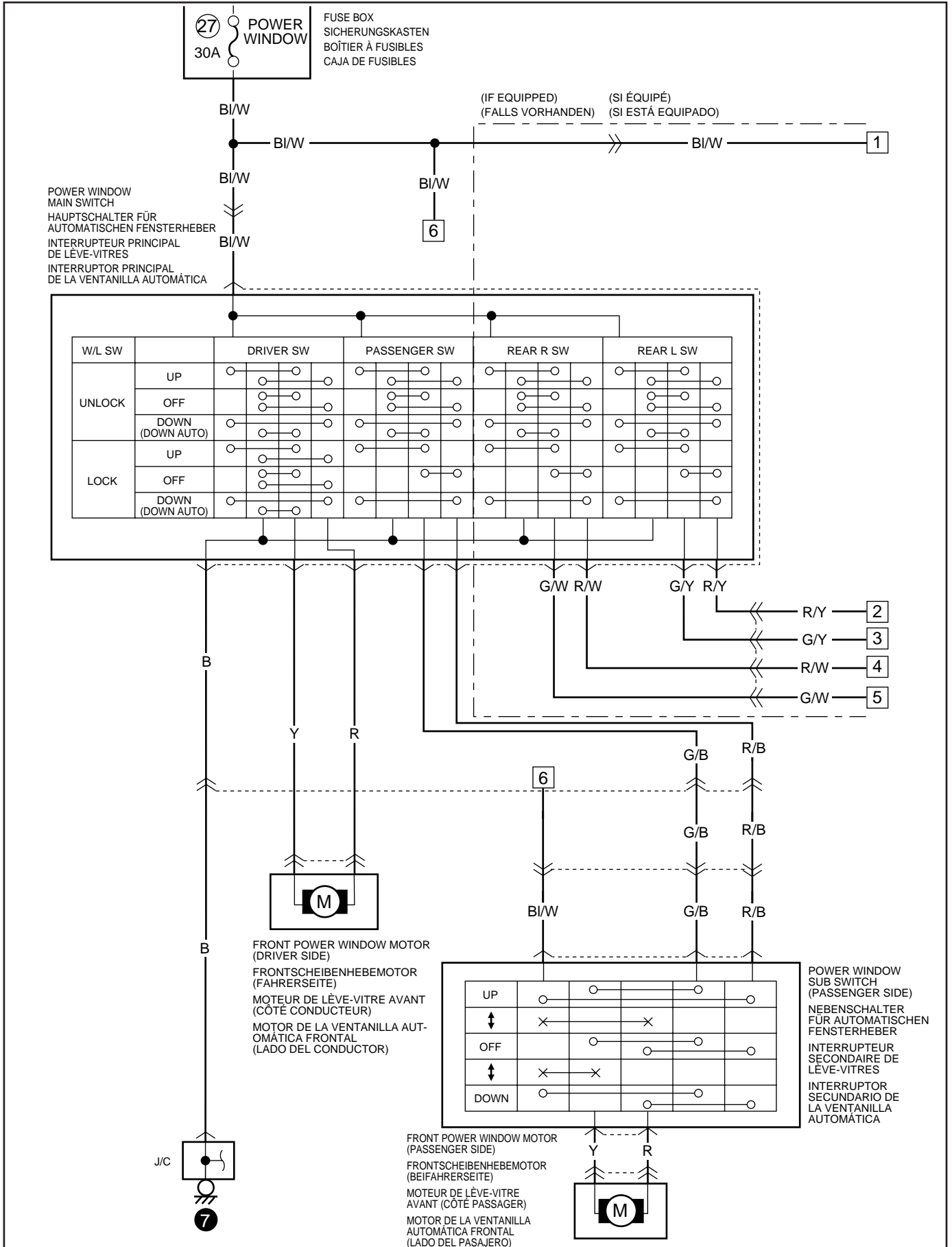

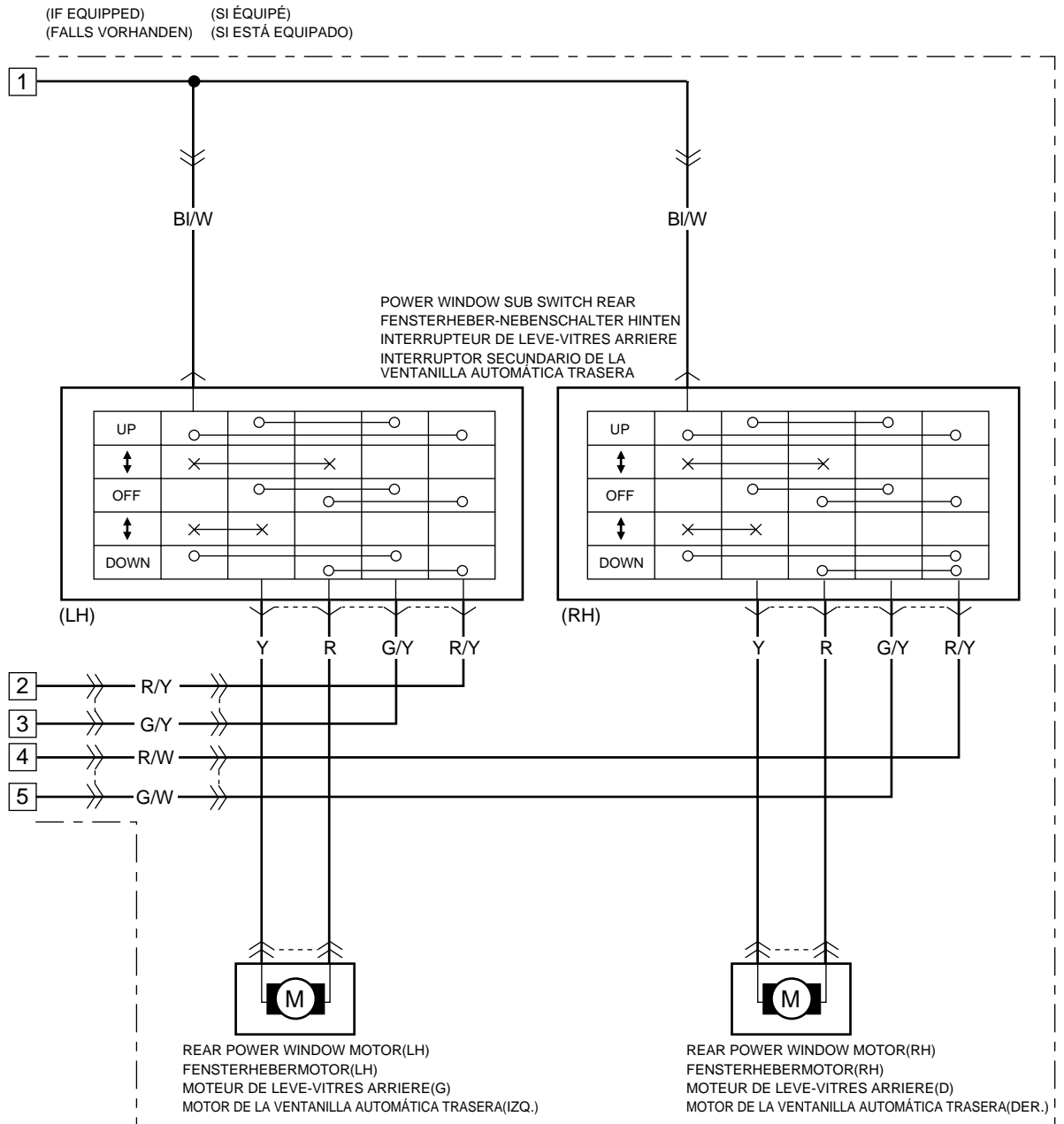

POWER DOOR LOCK
ELEKTRISCHE TÜRVERRIEGELUNG
VERROUILLAGE CENTRALISÉ DES PORTES
BLOQUEO AUTOMÁTICO DE LAS PUERTAS

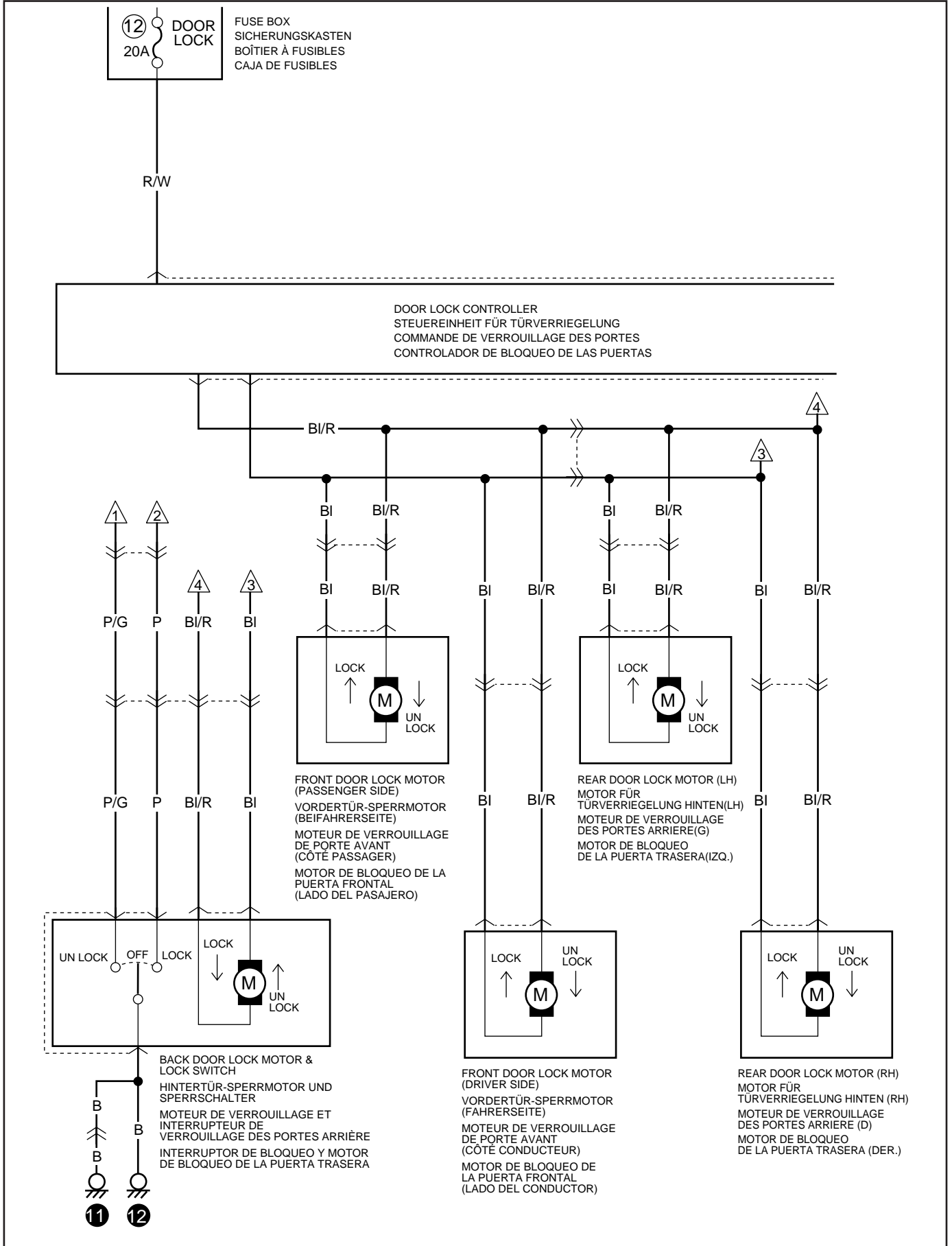

REMOTE CONTROLLED MIRROR
FERNBEDIENTER SPIEGEL
RÉTROVISEURS À COMMANDE À DISTANCE
ESPEJOS RETROVISORES DE CONTROL REMOTO

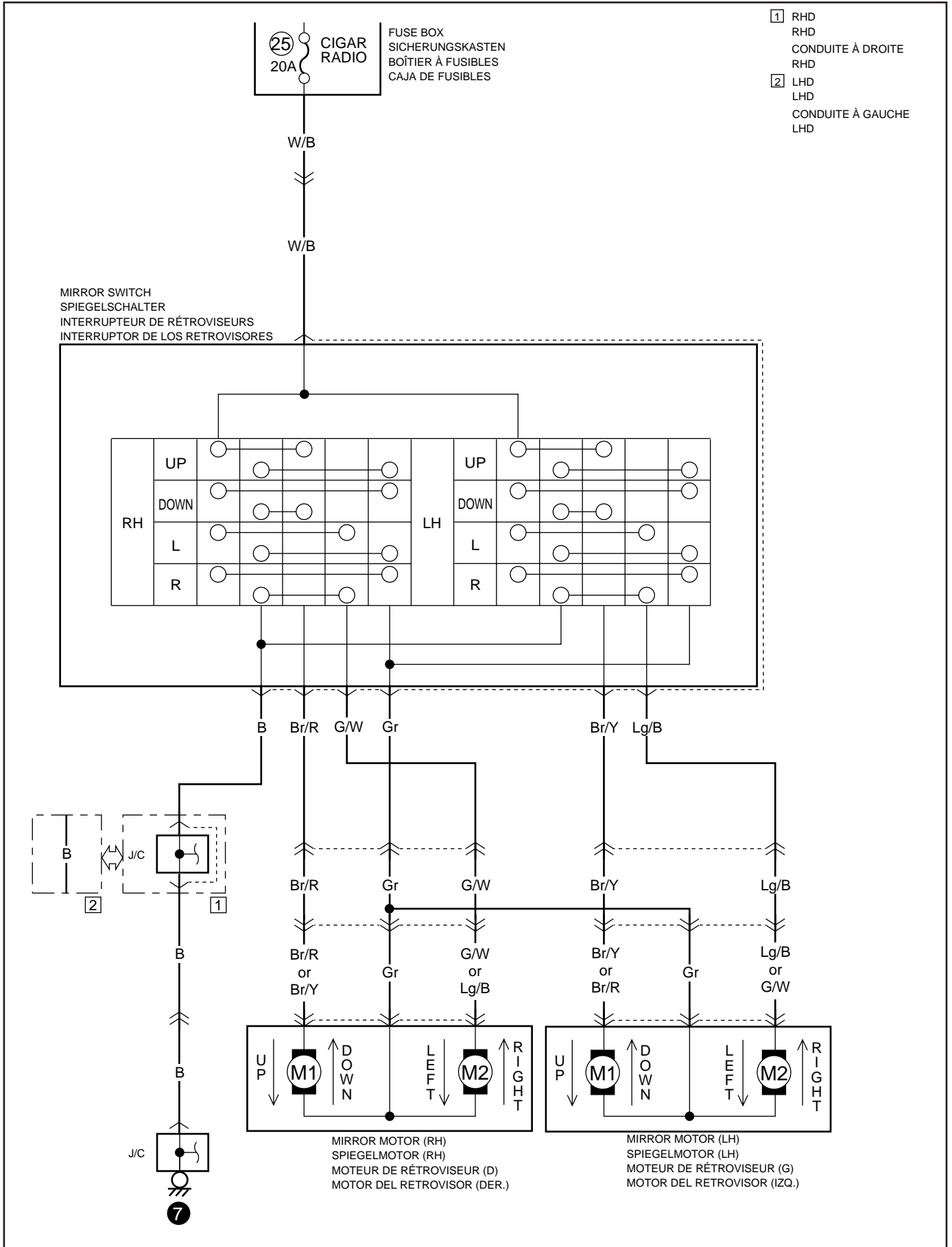

HORN
HUPE
AVERTISSEUR SONORE
BOCINA

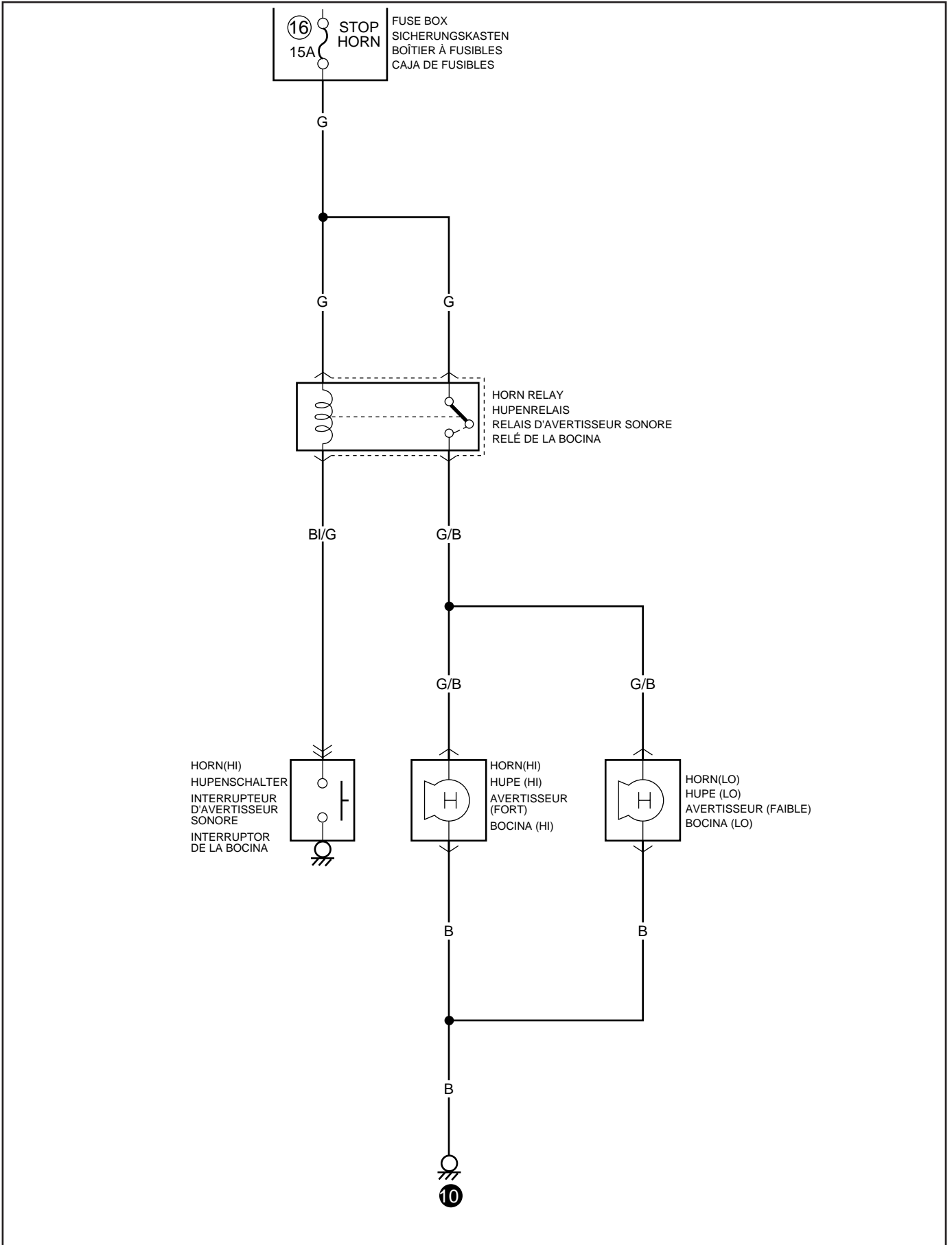

METER & GAUGE
MESSER UND ANZEIGE
COMPTEURS ET INDICATEURS
MEDIDORES Y CONTADORES

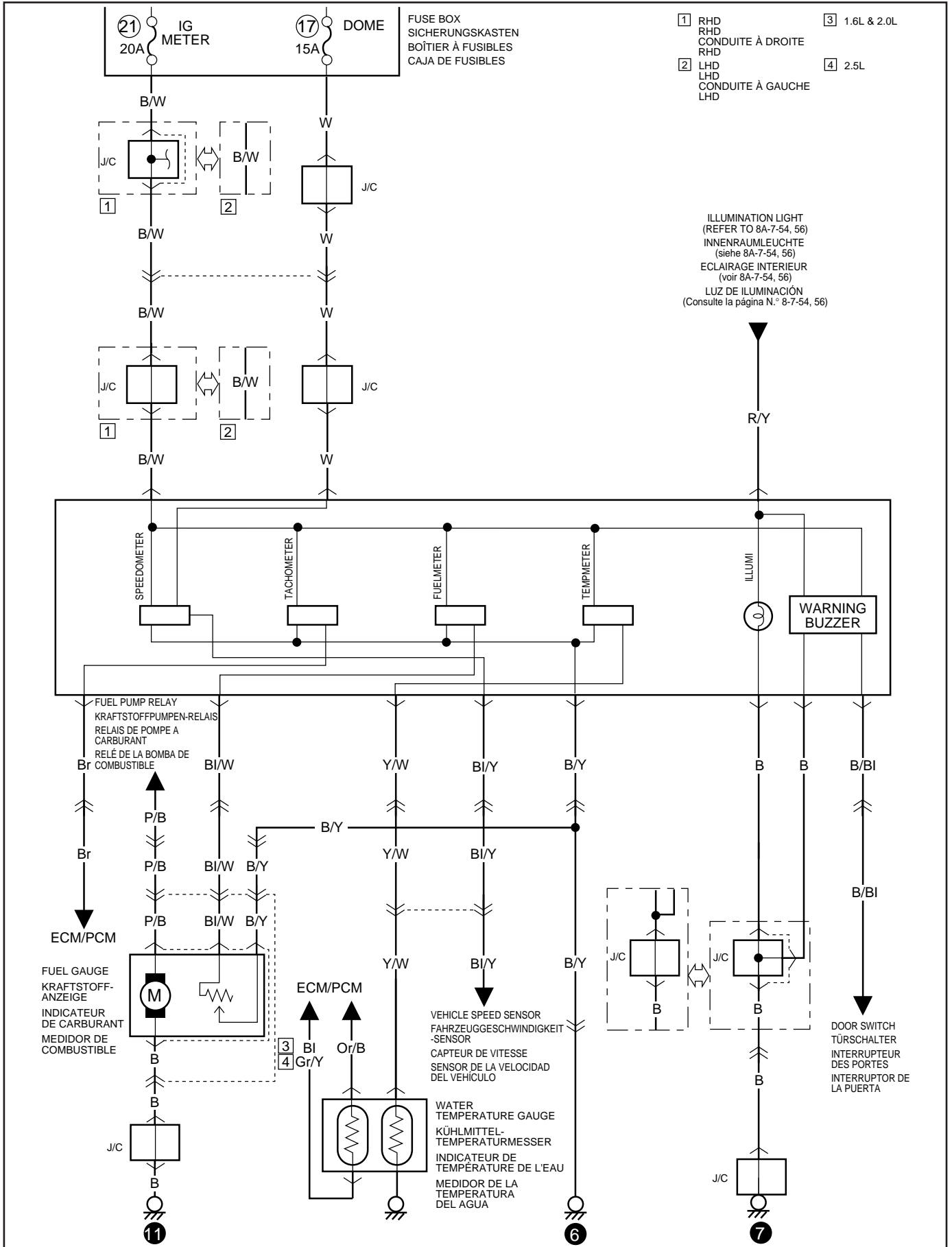

**INDICATOR LAMP
 KONTROLLEUCHTE
 INDICATEURS TÉMOINS
 LÁMPARAS INDICADORAS**

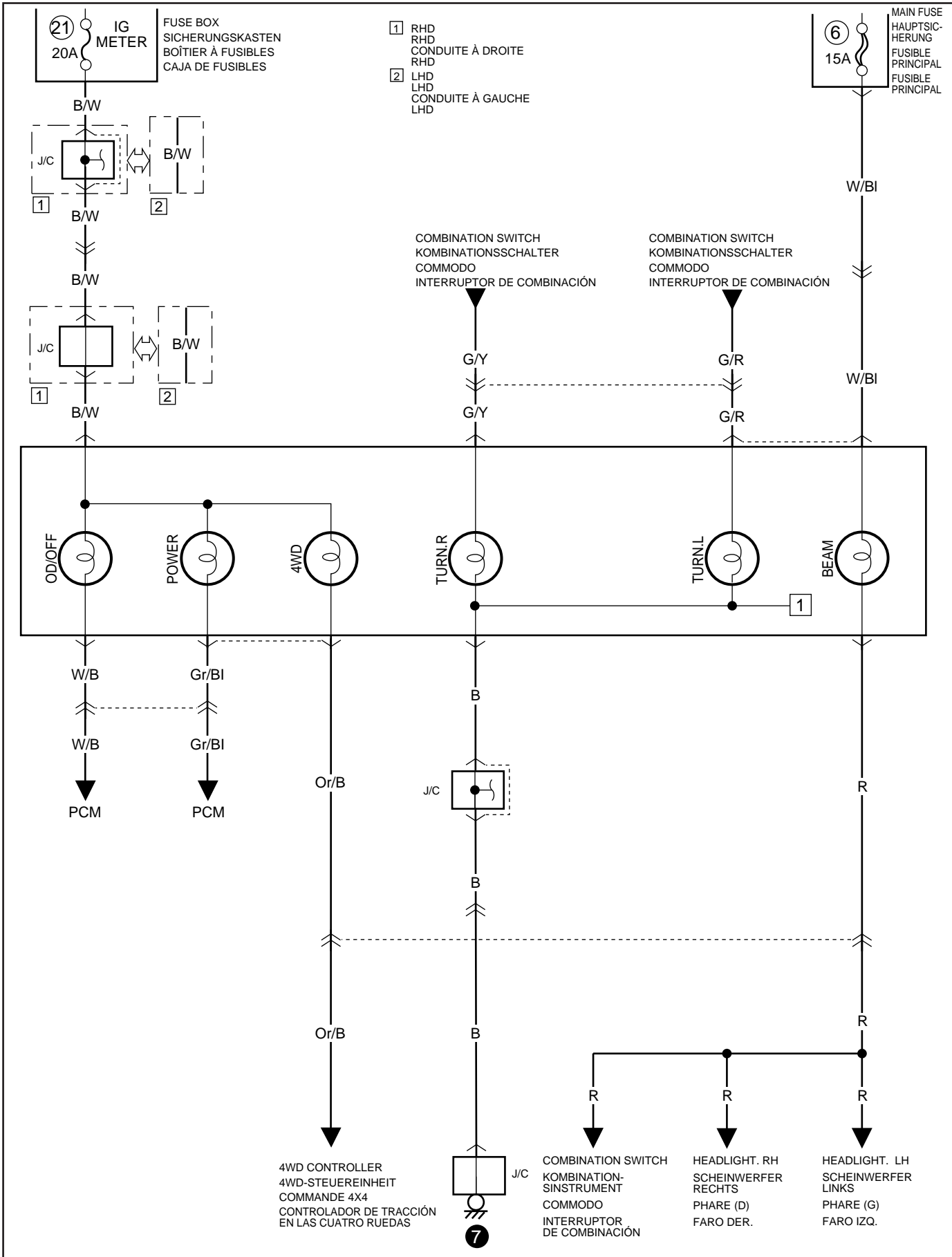

INDICATOR LAMP
KONTROLLEUCHTE
INDICATEURS TÉMOINS
LÁMPARAS INDICADORAS

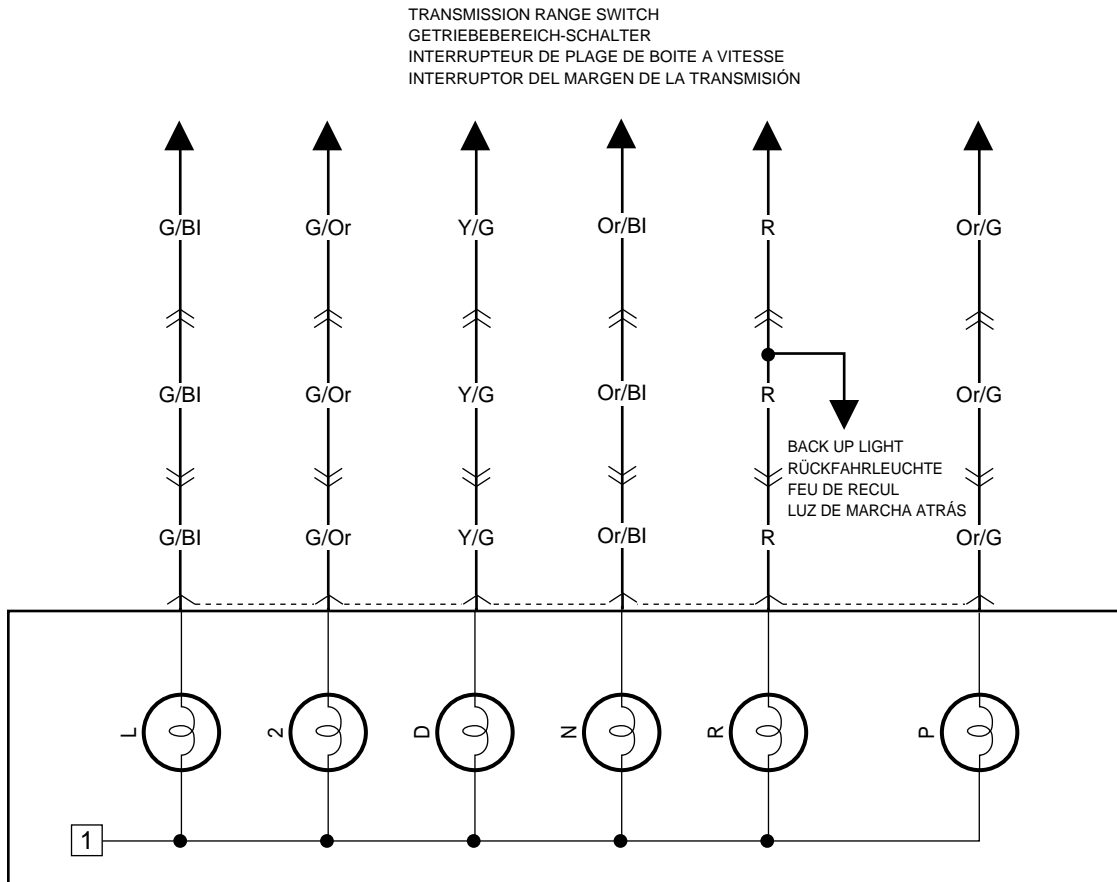

MEMO
NOTIZEN
NOTE
NOTAS

WARNING LAMP
WARNLEUCHTE
TÉMOINS D'AVERTISSEMENT
LÁMPARA DE ADVERTENCIA

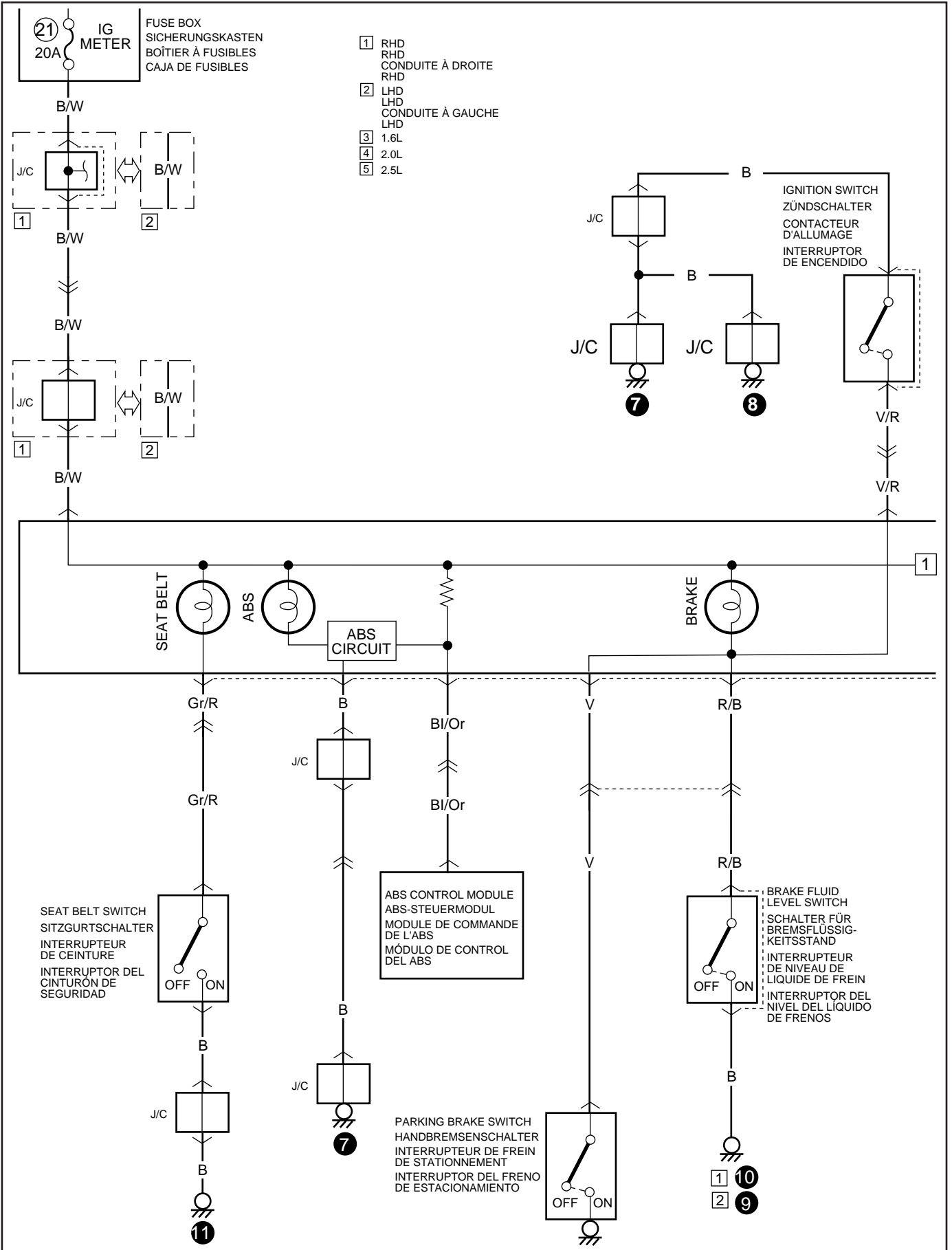

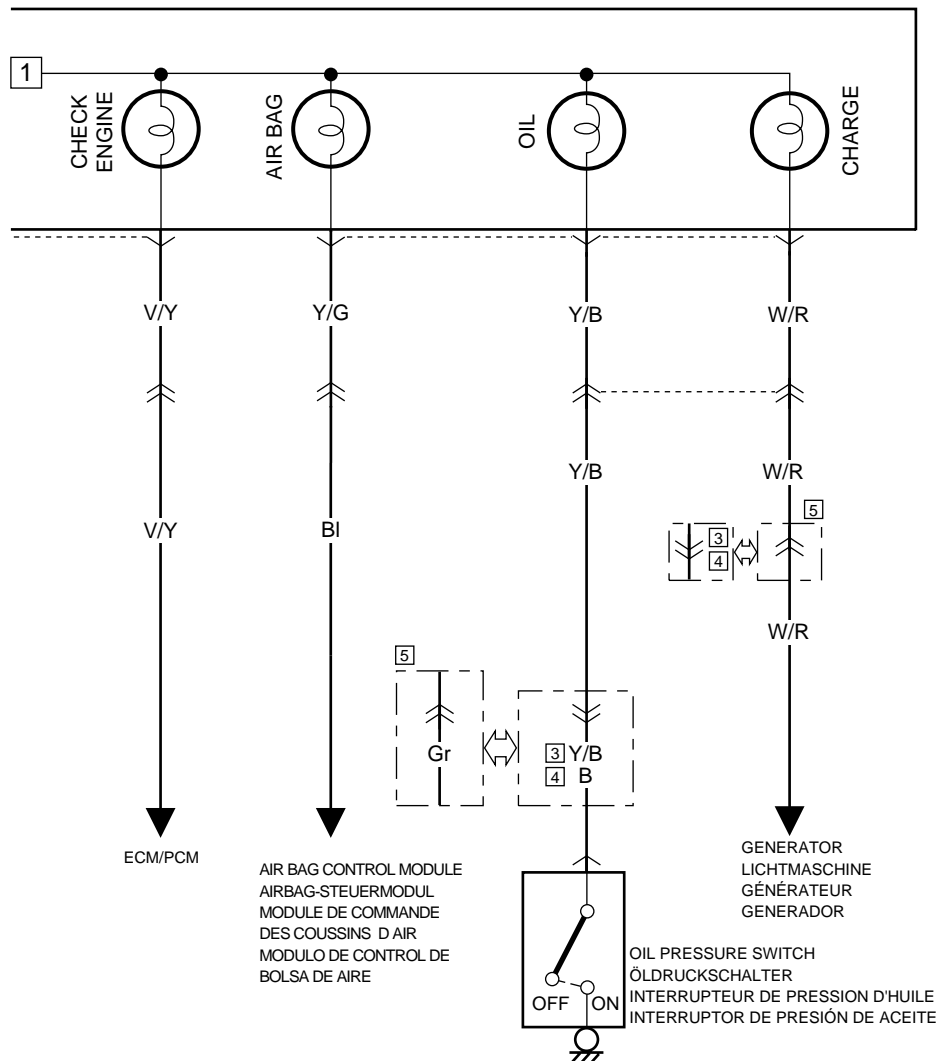

HEADLIGHT SYSTEM
SCHEINWERFERANLAGE
SYSTÈME DES PHARES
SISTEMA DE LOS FAROS

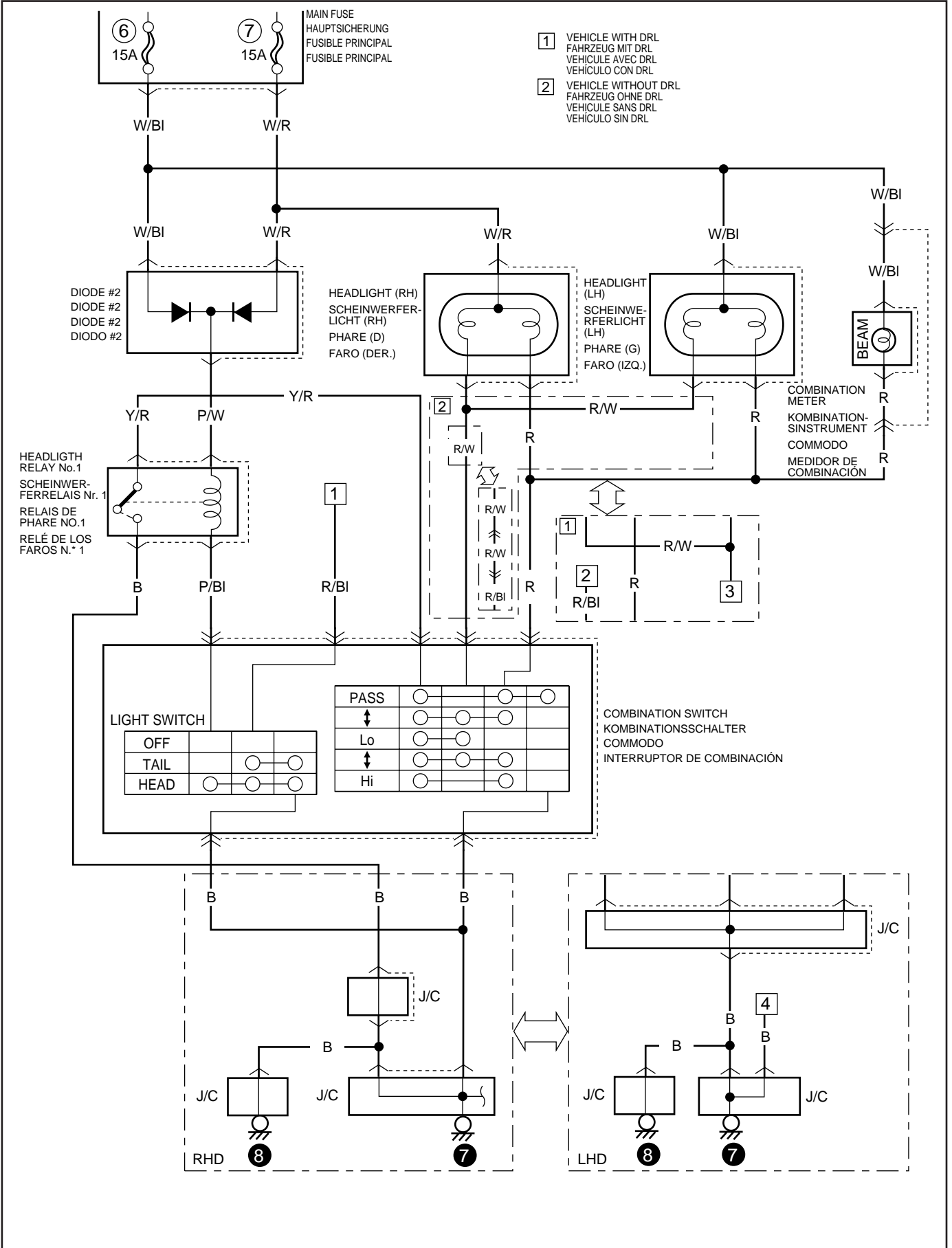

POSITION, TAIL AND LICENSE PLATE LIGHT
BEGRENZUNGS-, HECK- UND KENNZEICHENLEUCHTE
FEUX DE GABARIT, ARRIÈRE ET DE PLAQUE D'IMMATICULATION
LUCE DE PASO, COLA Y DE LA MATRÍCULA

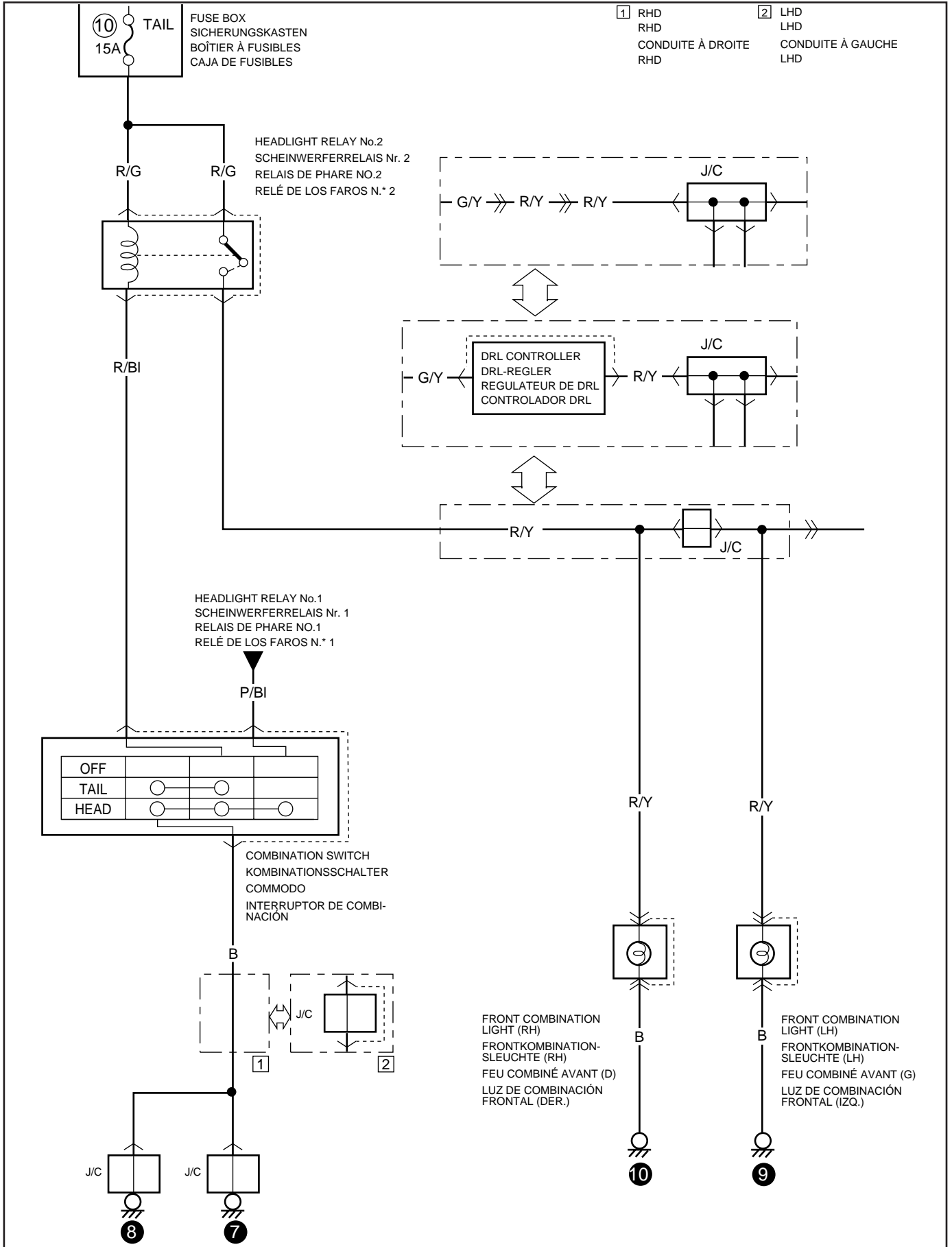

- 1 RHD
RHD
CONDUITE À DROITE
RHD
- 2 LHD
LHD
CONDUITE À GAUCHE
LHD
- 3 VEHICLE WITH RR FOG LIGHT
FAHRZEUG MIT NEBELLEUCHTE RECHTS HINTEN
VEHICULE AVEC FEU ANTIBROUILLARD ARRIERE DROIT
LUZ ANTINEBLA DEL VEHICULO TRASERA
- 4 VEHICLE WITHOUT RR FOG LIGHT
FAHRZEUG OHNE NEBELLEUCHTE RECHTS HINTEN
VEHICULE SANS FEU ANTIBROUILLARD
VEHICULO SIN LUZ ANTINEBLA TRASERA

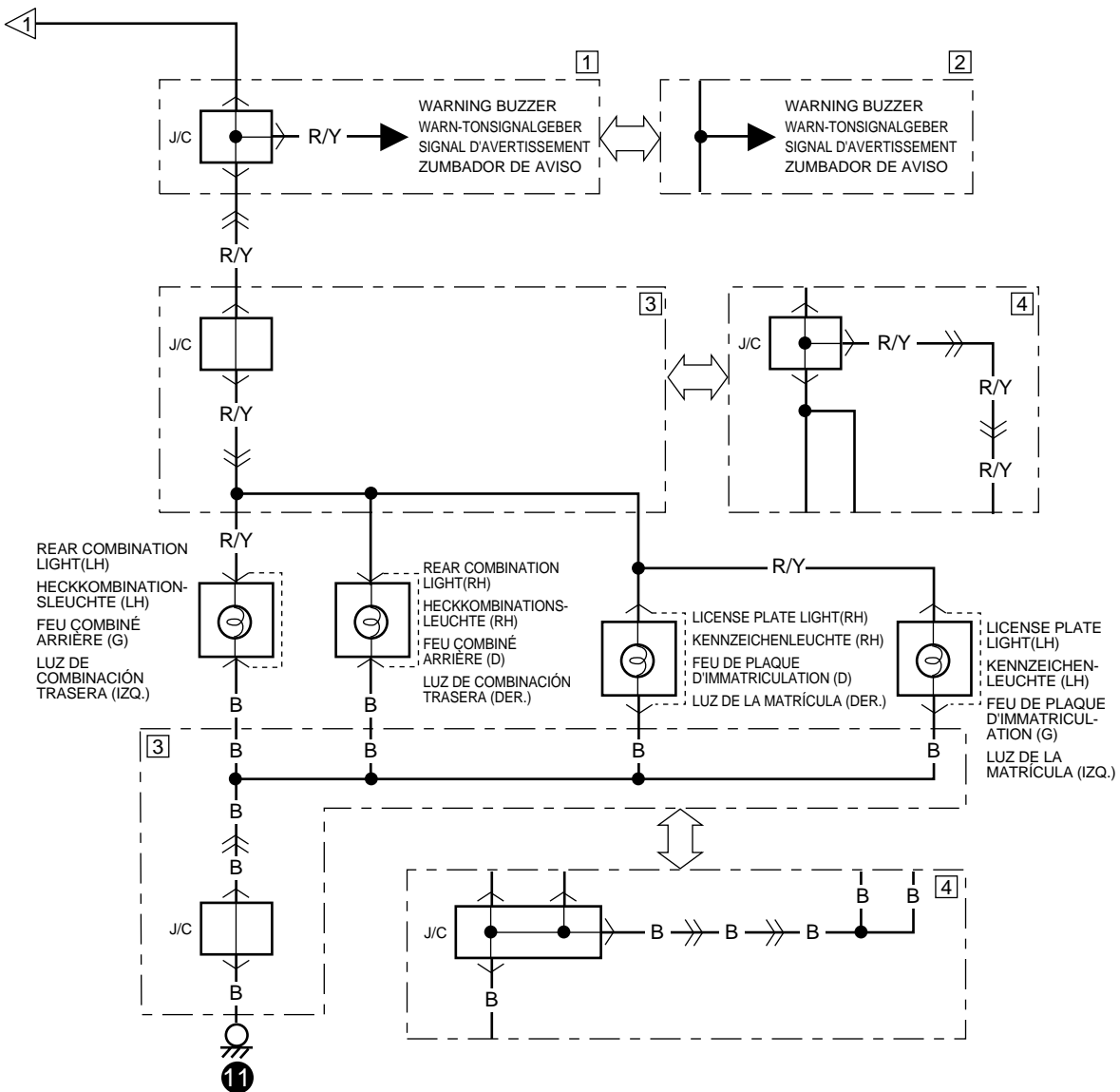

ILLUMINATION LAMP (RIGHT HAND STEERING VEHICLE)
BELEUCHTUNGSLAMPE (FAHRZEUG MIT RECHTSLENKUNG)
LAMPES TÉMOINS (VEHICULE A CONDUITE A DROITE)
LÁMPARAS DE ILUMINACIÓN (VEHÍCULO CON DIRECCIÓN A LA DERECHA)

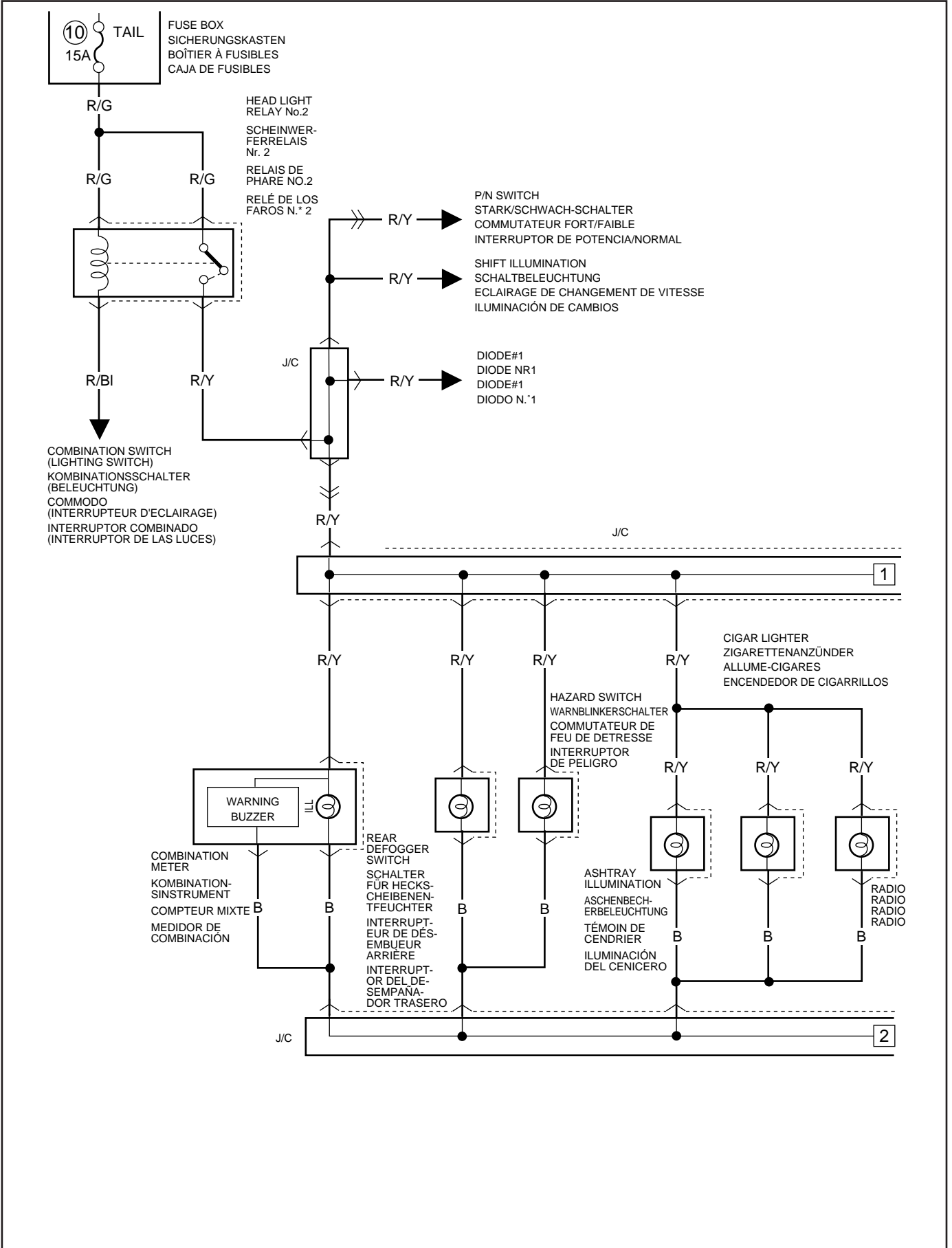

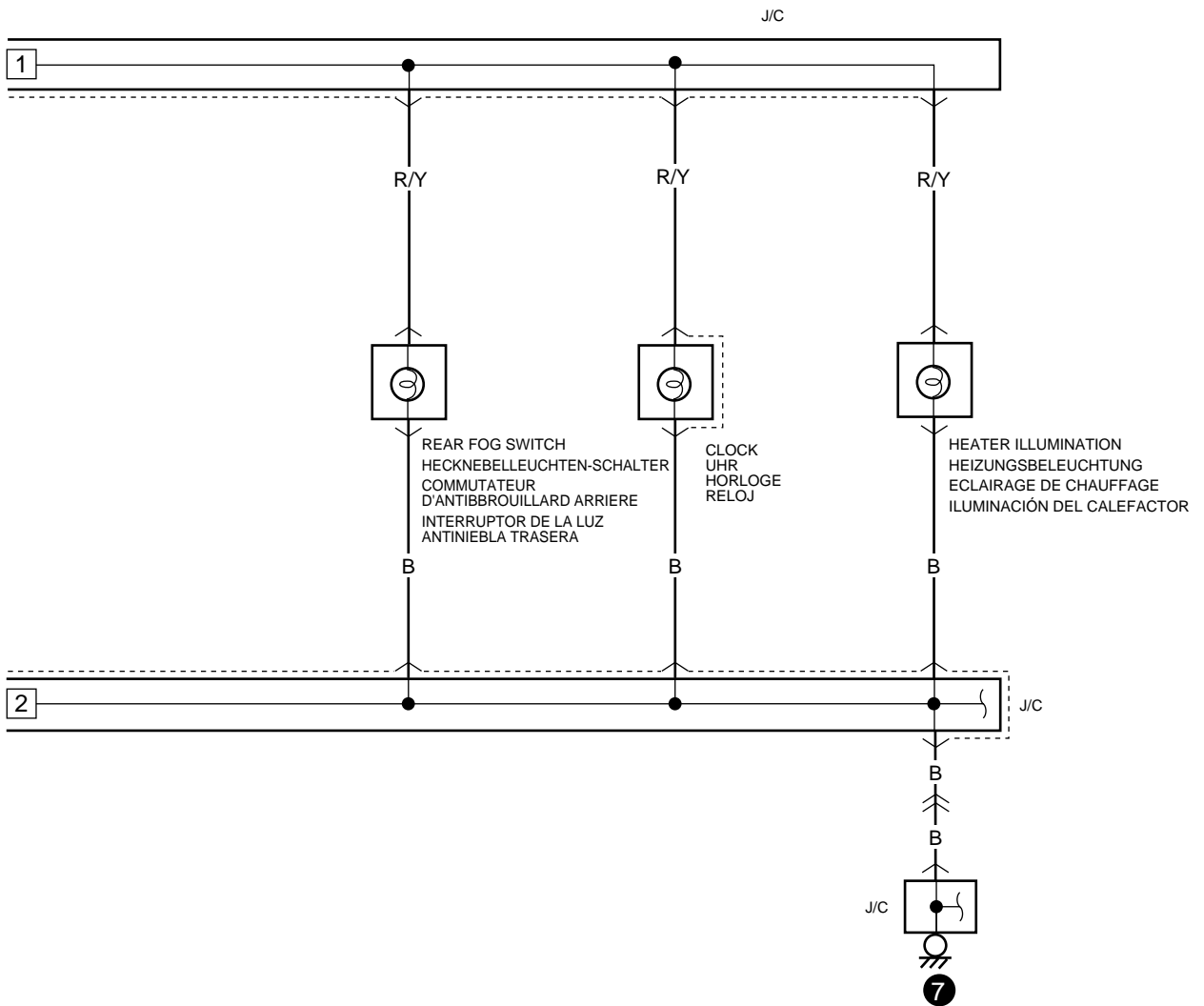

ILLUMINATION LAMP (LEFT HAND STEERING VEHICLE)
BELEUCHTUNGSLAMPE (FAHRZEUG MIT LINKSLENKUNG)
LAMPES TÉMOINS (VEHICULE A CONDUITE A GAUCHE)
LÁMPARAS DE ILUMINACIÓN (VEHÍCULO CON DIRECCIÓN A LA IZQUIERDA)

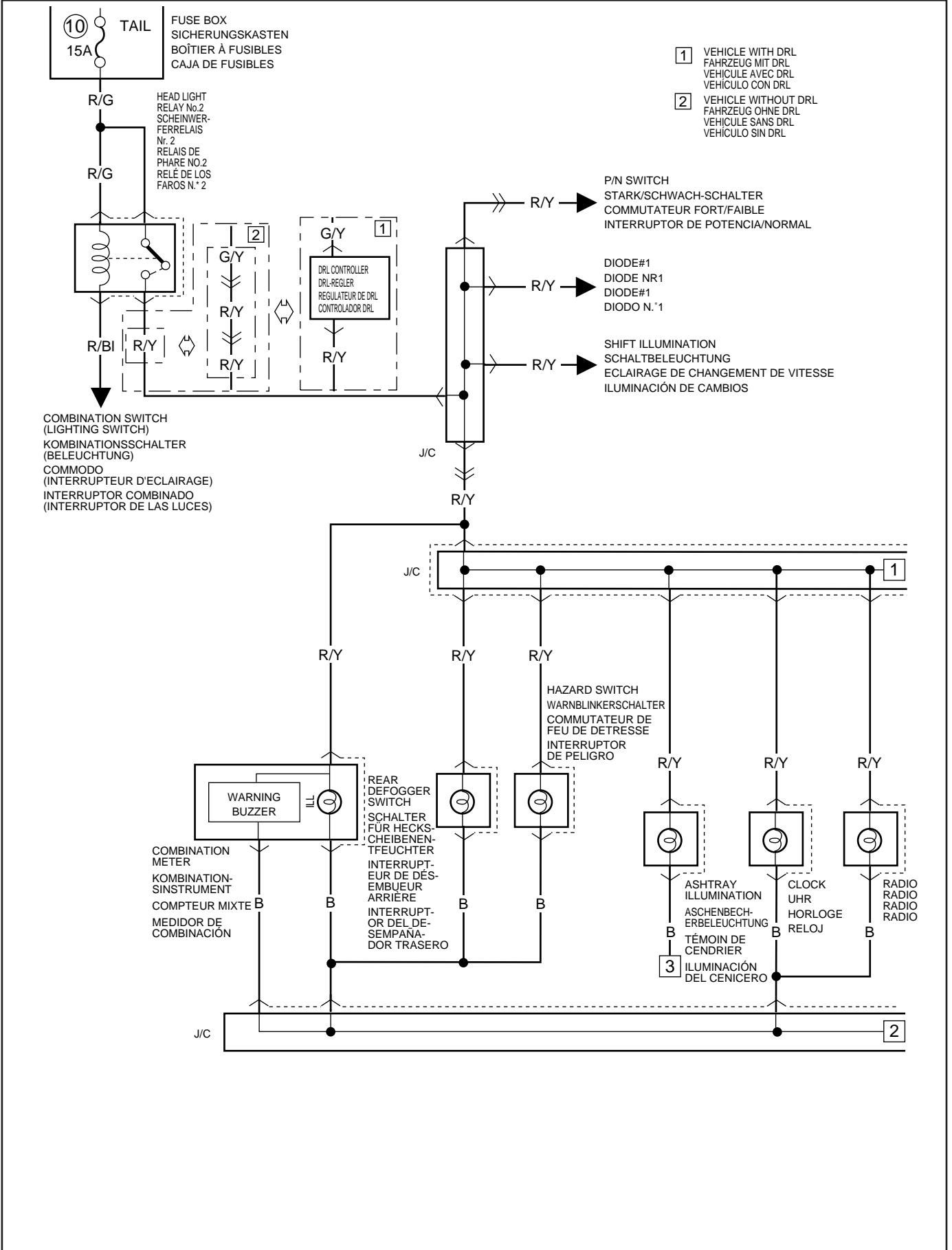

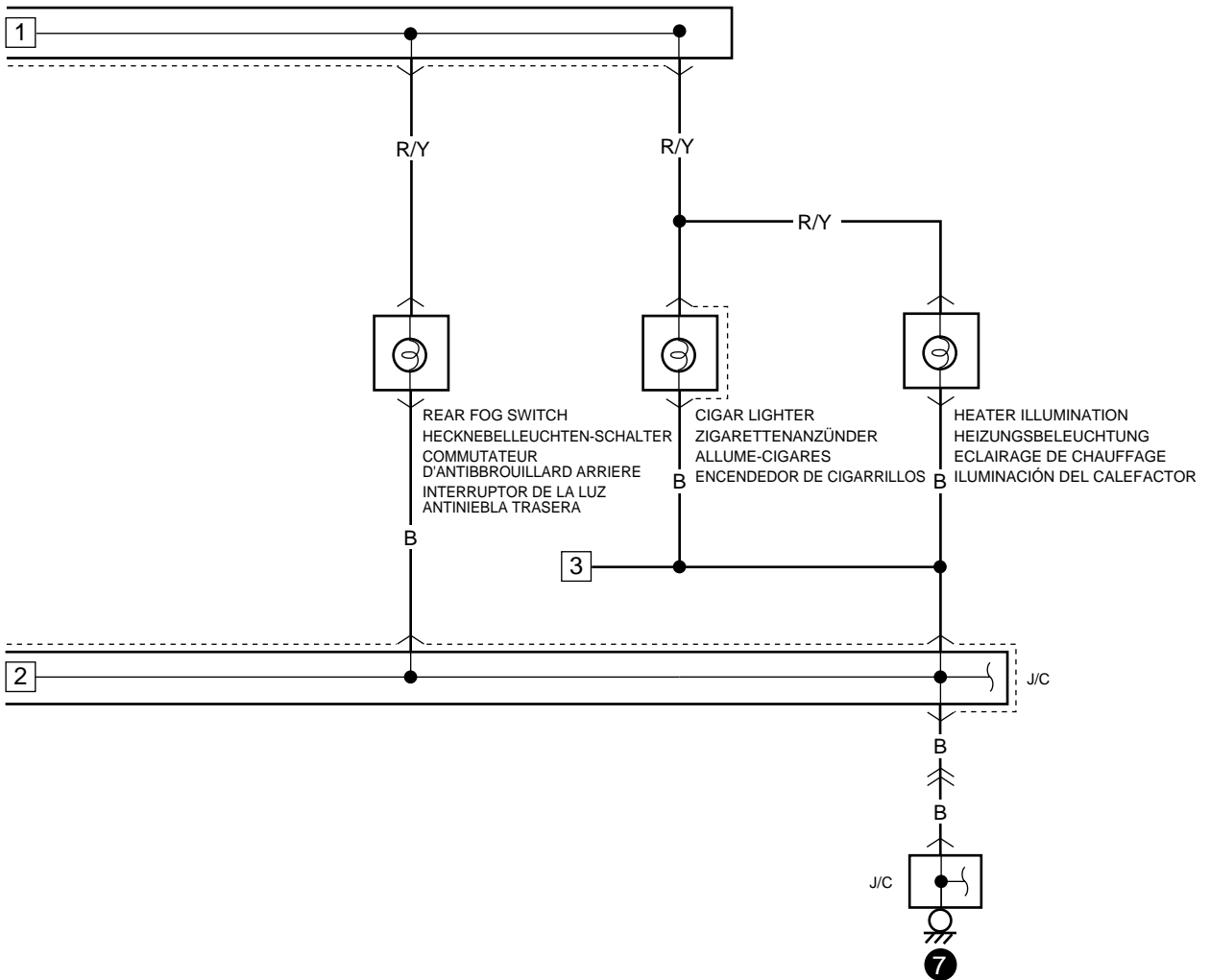

MEMO
NOTIZEN
NOTE
NOTAS

TURN SIGNAL AND HAZARD WARNING LIGHT
BLINKLICHT UND WARNLEUCHE
FEUX CLIGNOTANTS ET FEUX DE DÉTRESSE
LUZ DE LA SEÑAL DE GIRO Y DE ADVERTENCIA DE PELIGRO

- 1 RHD
RHD
CONDUITE À DROITE
RHD
- 2 LHD
LHD
CONDUITE À GAUCHE
LHD
- 3 VEHICLE WITH RR FOG LIGHT
FAHRZEUG MIT NEBELLEUCHE RECHTS HINTEN
VEHICULE AVEC FEU ANTIBROUILLARD ARRIÈRE DROIT
LUZ ANTINEBLA DEL VEHÍCULO TRASERA
- 4 VEHICLE WITHOUT RR FOG LIGHT
FAHRZEUG OHNE NEBELLEUCHE RECHTS HINTEN
VEHICULE SANS FEU ANTIBROUILLARD
VEHÍCULO SIN LUZ ANTINEBLA TRASERA

COMBINATION SWITCH
 KOMBINATIONSSCHALTER
 COMMODO
 INTERRUPTOR DE COMBINACIÓN

L	○	○	
LL'	○	○	
N			
RR'		○	○
R		○	○
LNR	○	○	○

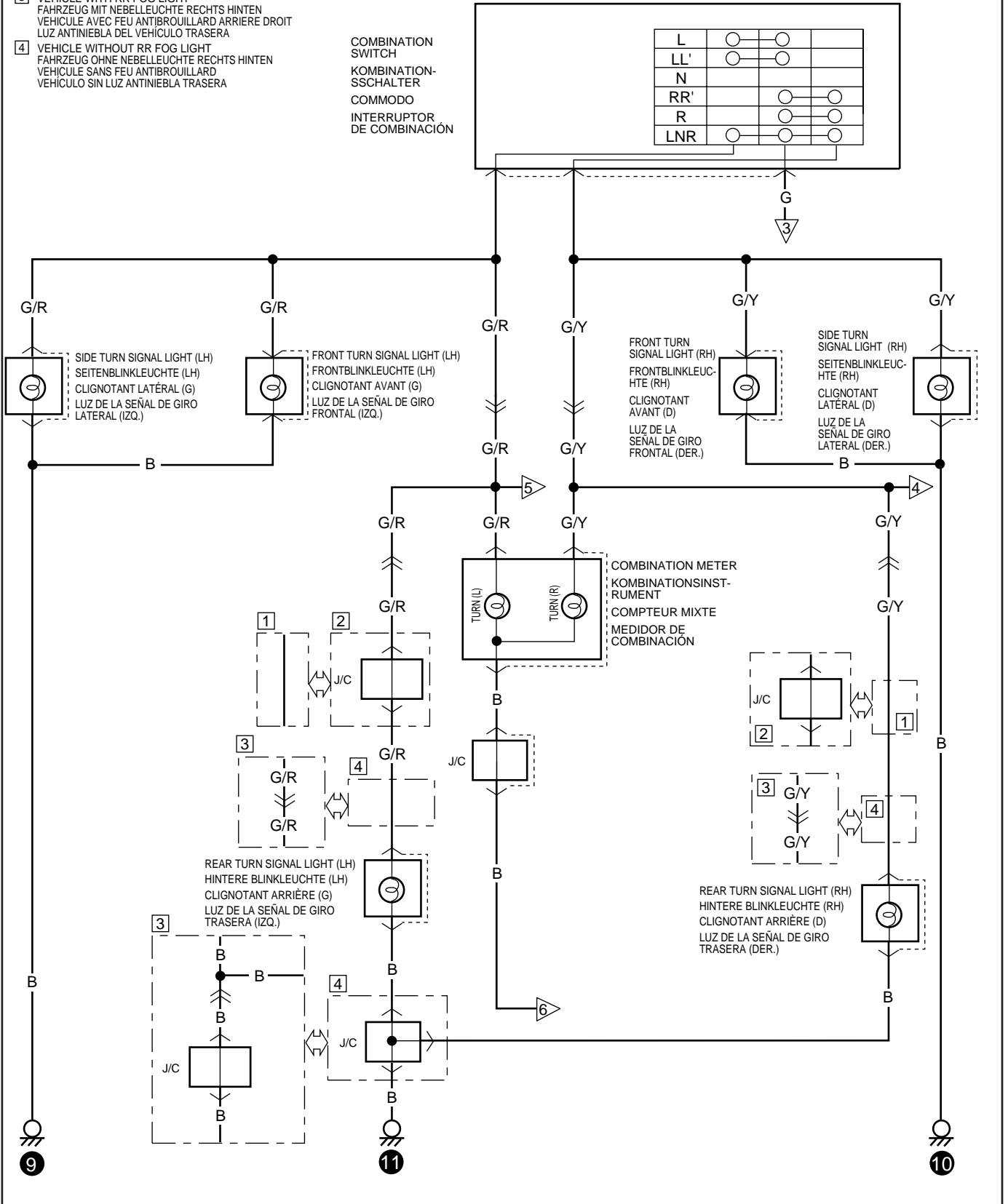

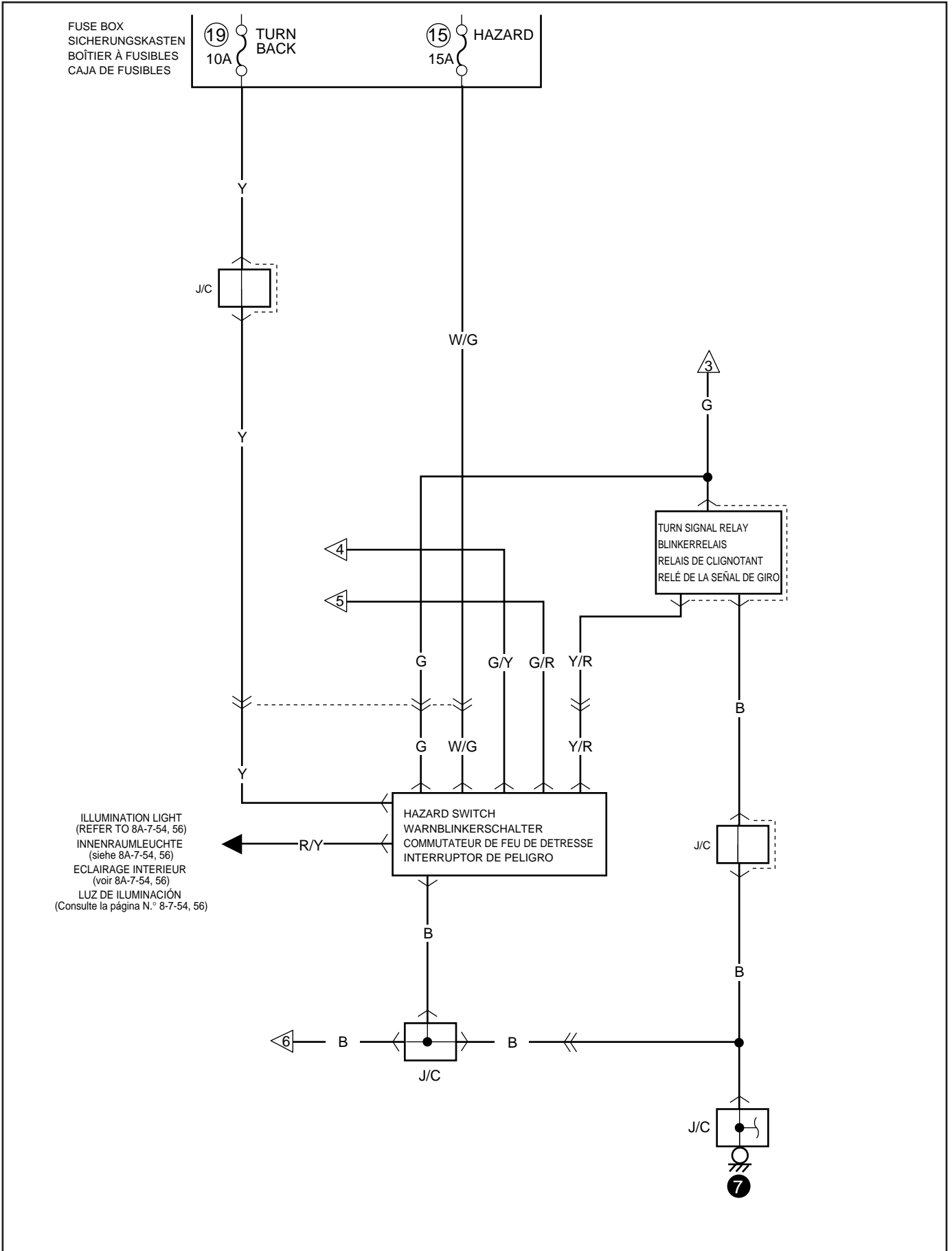

**BRAKE LIGHT
 BREMSLEUCHE
 FEUX STOP
 LUZ DEL FRENO**

- 1 AT MODELS OF NON SAUDIARABIAN SPEC AND ALL THE MT MODELS
 A/T-MODELLE (AUSSER FÜR SAUDI-ARABIEN) UND ALLE MT-MODELLE
 MODÈLES SAUF ARABIE SAOUDITE ET TOUS LES MODÈLES À BOÎTE MANUELLE
 MODELOS DE AT DE ESPEC. QUE NO SON PARA ARABIA SAUDITA Y TODOS LOS MODELOS DE MT
- 2 AT MODEL OF SAUDIARABIAN SPEC
 A/T-MODELLE FÜR SAUDI-ARABIEN
 MODÈLE ARABIE SAOUDITE
 MODELO DE AT DE ESPEC. PARA ARABIA SAUDITA
- 3 VEHICLE WITH RR FOG LIGHT
 FAHRZEUG MIT NEBELLEUCHE RECHTS HINTEN
 VEHICULE AVEC FEU ANTIBROUILLARD ARRIERE DROIT
 LUZ ANTINEBLA DEL VEHICULO TRASERA
- 4 VEHICLE WITHOUT RR FOG LIGHT
 FAHRZEUG OHNE NEBELLEUCHE RECHTS HINTEN
 VEHICULE SANS FEU ANTIBROUILLARD
 VEHICULO SIN LUZ ANTINEBLA TRASERA



FUSE BOX
 SICHERUNGSKASTEN
 BOÎTIER À FUSIBLES
 CAJA DE FUSIBLES

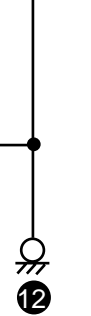
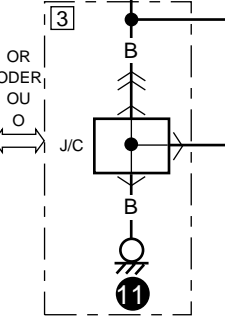
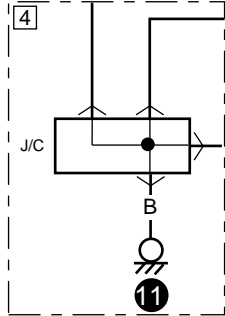
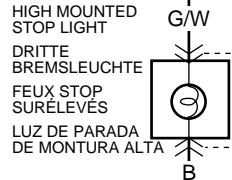
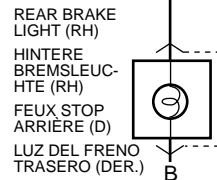
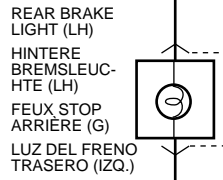
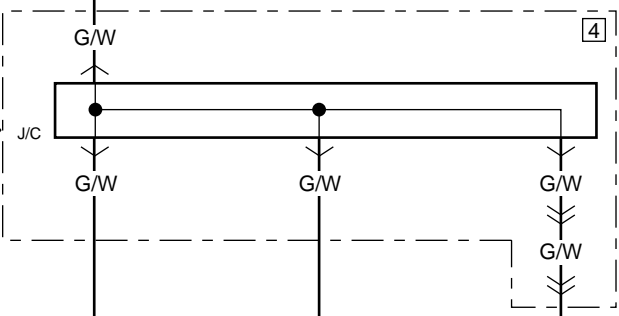
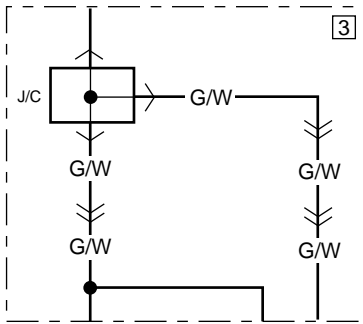
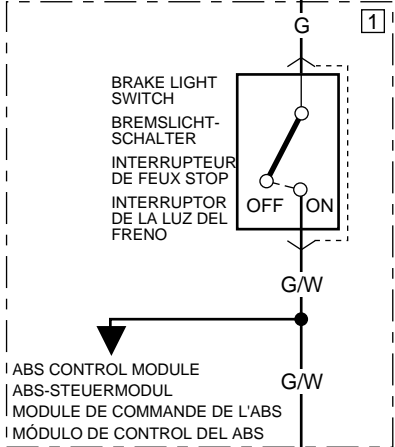
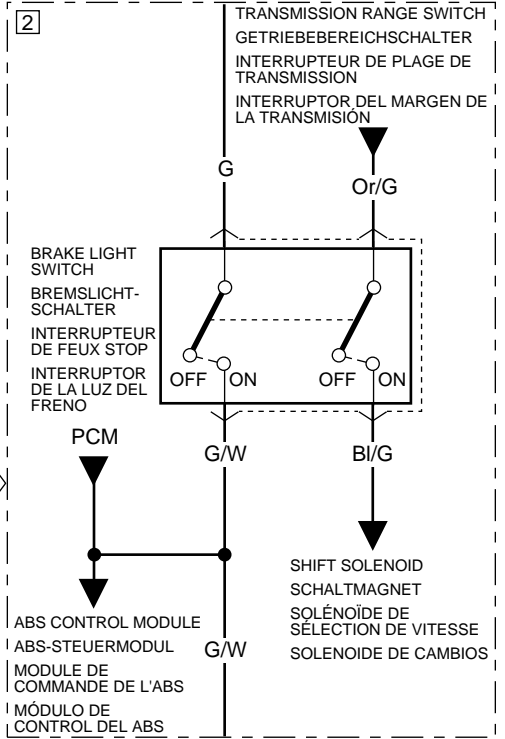

BACK-UP LIGHT
RÜCKFAHRLEUCHTE
FEUX DE MARCHE ARRIÈRE
LUZ DE MARCHA ATRÁS

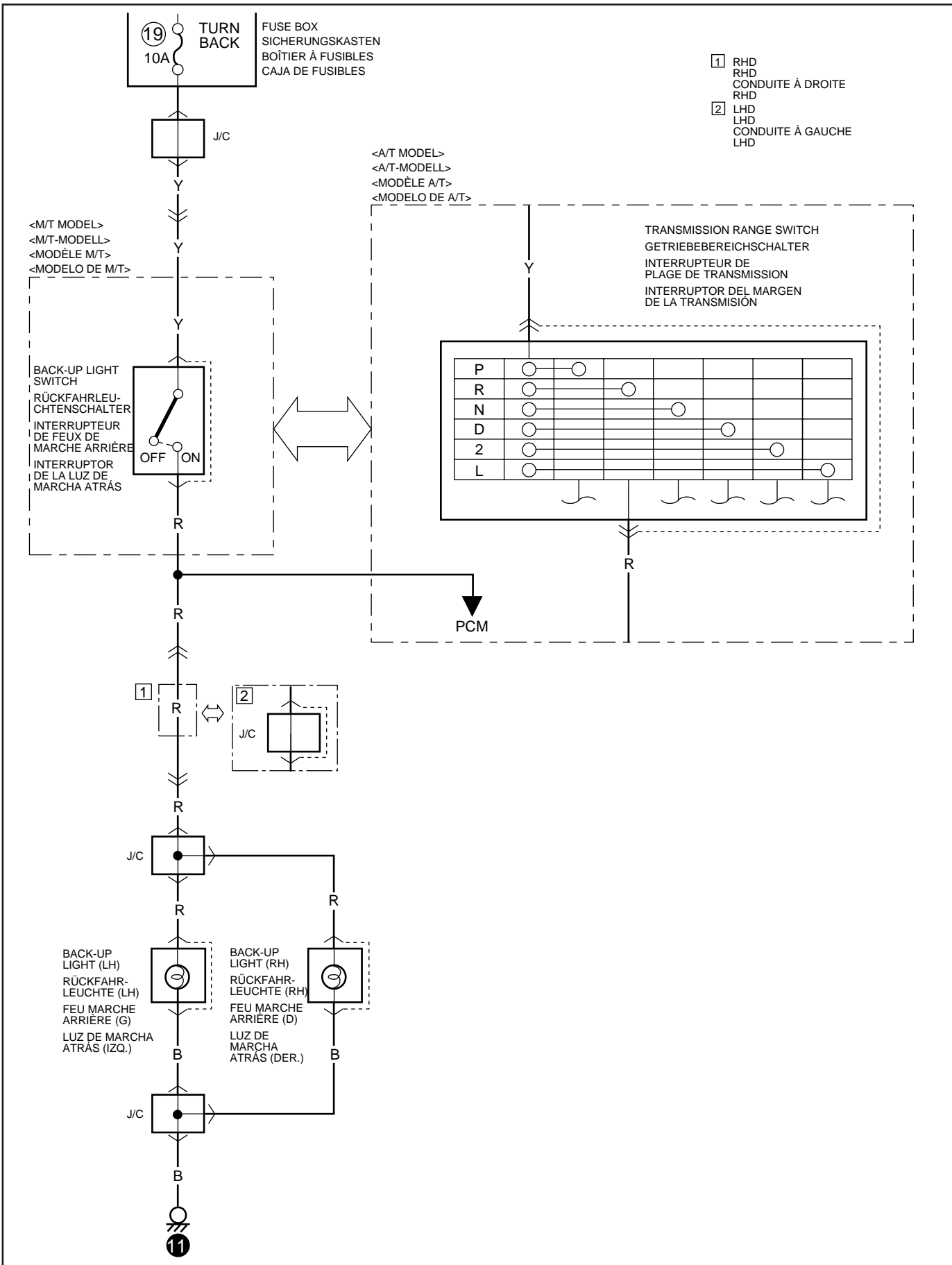

MEMO

NOTIZEN

NOTE

NOTAS

HEATER AND AIR CONDITIONING
HEIZUNG UND KLIMAANLAGE
CHAUFFAGE ET CLIMATISATION
CALEFACTOR Y ACONDICIONADOR DE AIRE

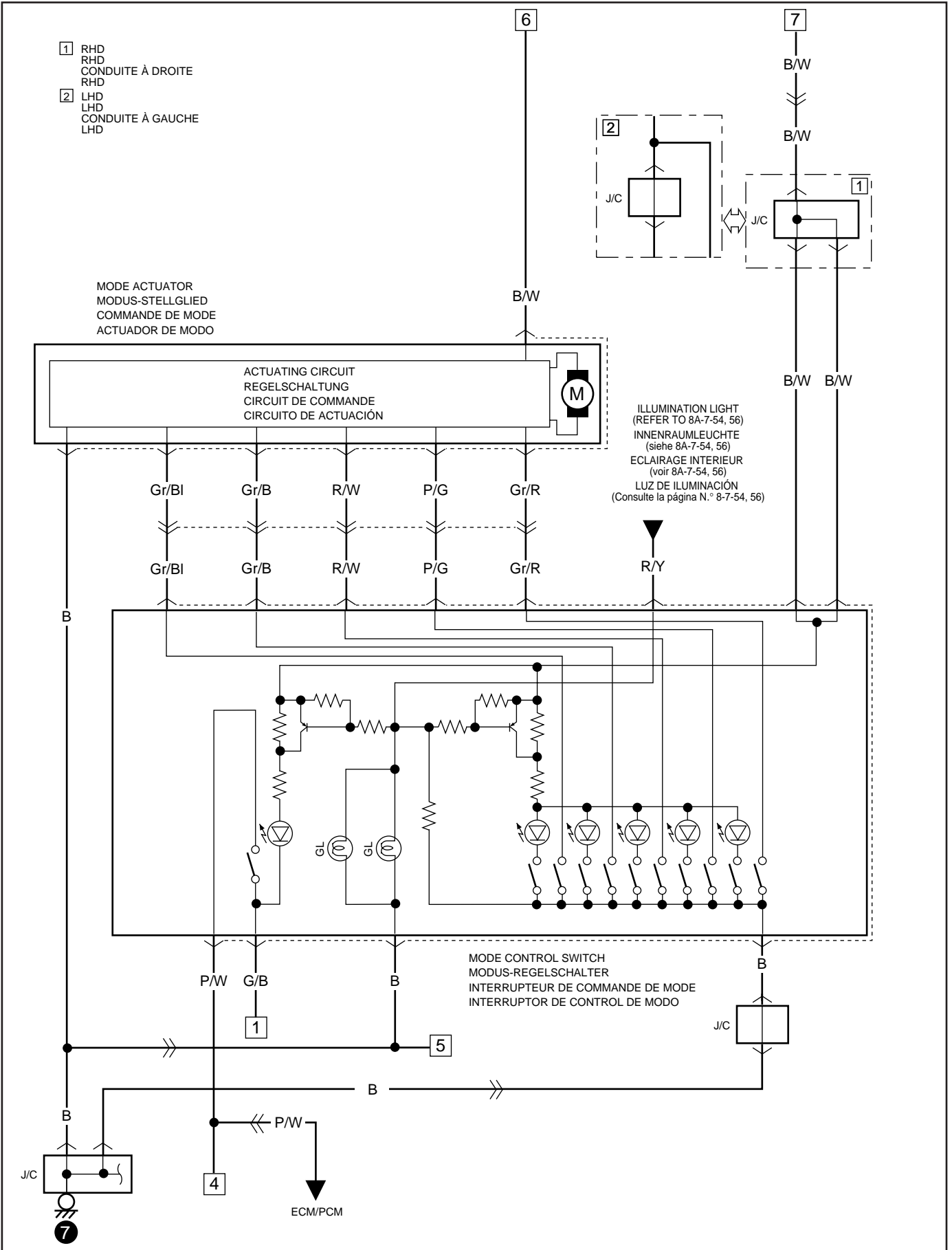

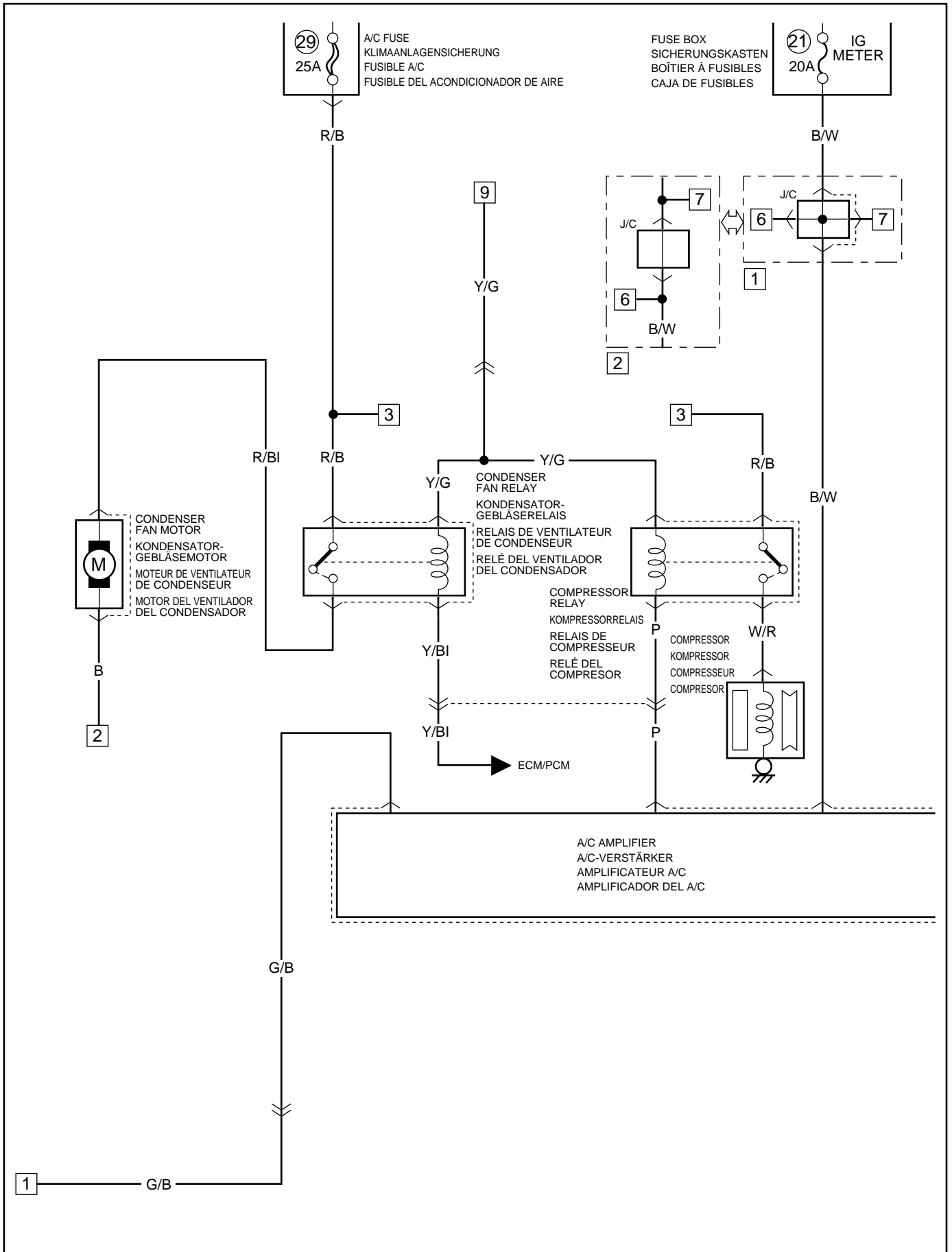

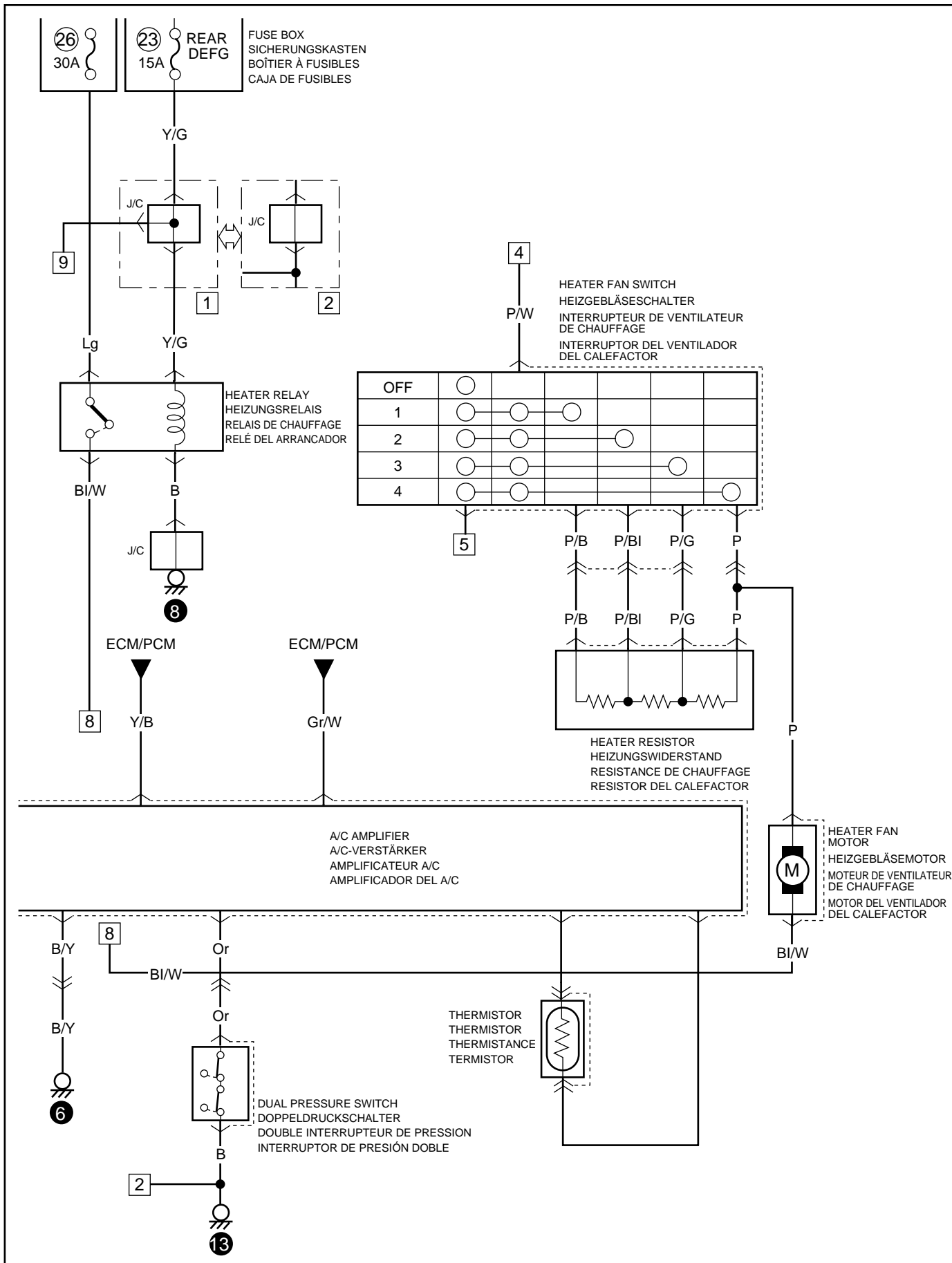

RADIO
 RADIO
 RADIO
 RADIO

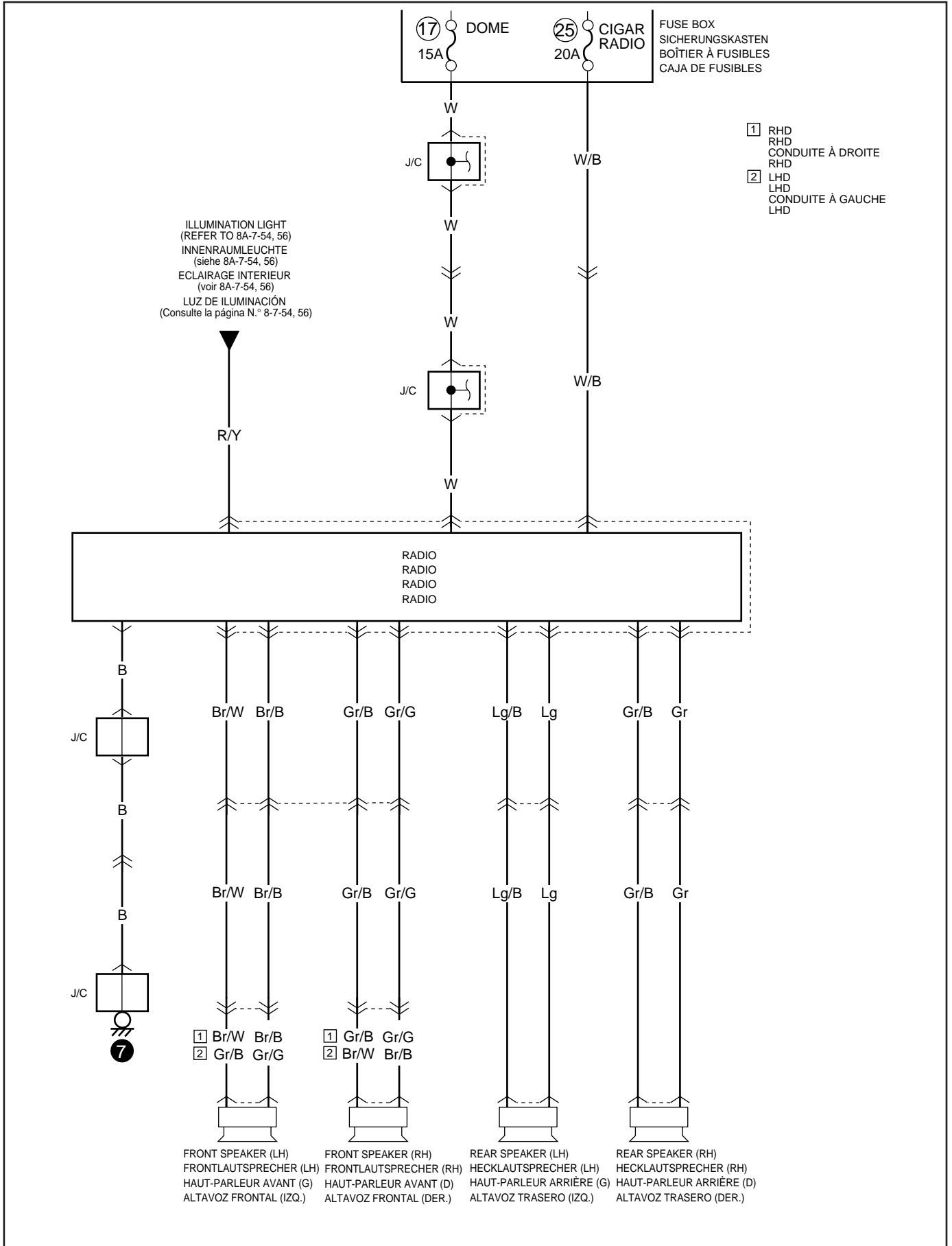

CLOCK
 UHR
 HORLOGE
 RELOJ

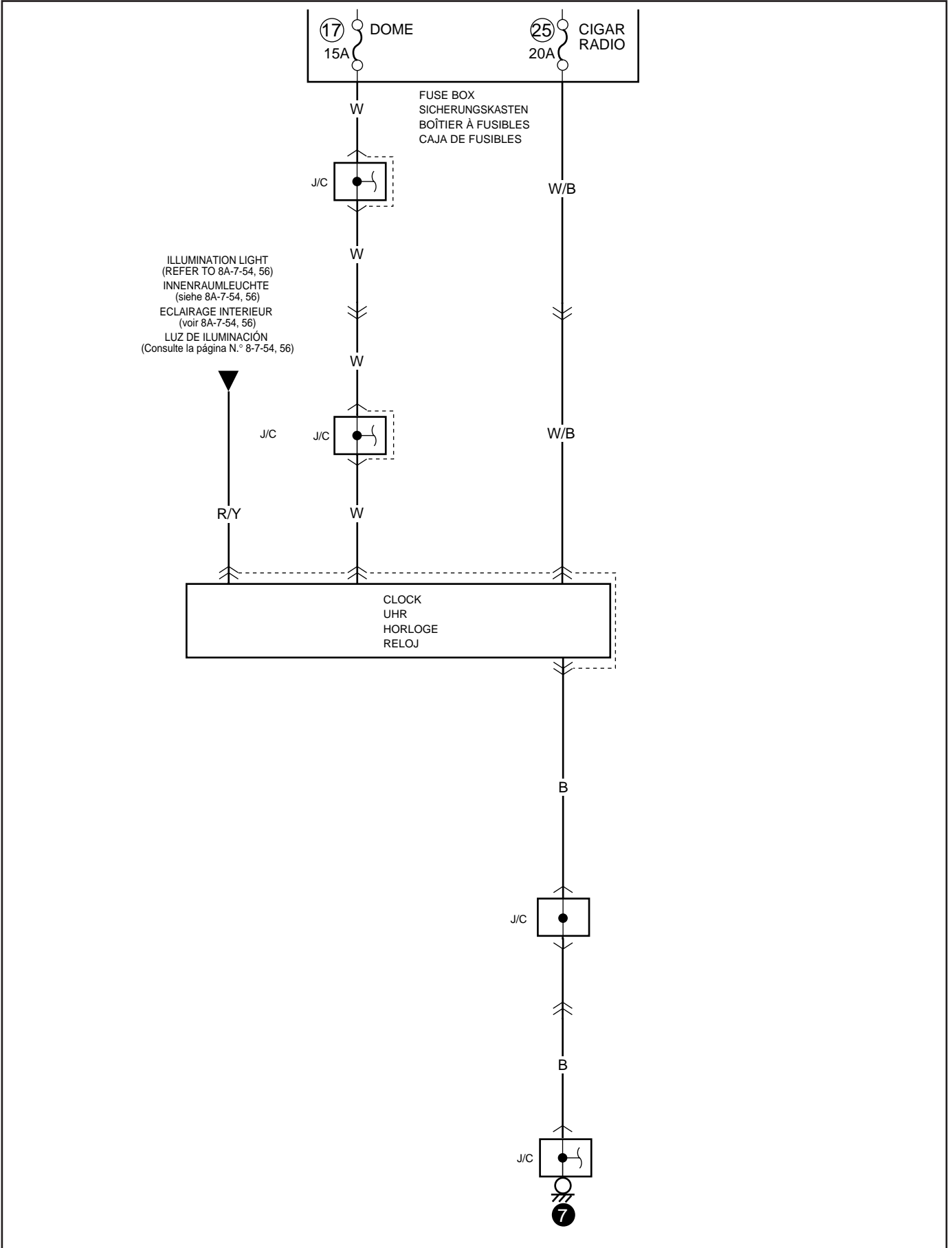

CIGAR LIGHTER
ZIGARRENANZÜNDER
ALLUME-CIGARES
ENCENDEDOR DE CIGARRILLOS

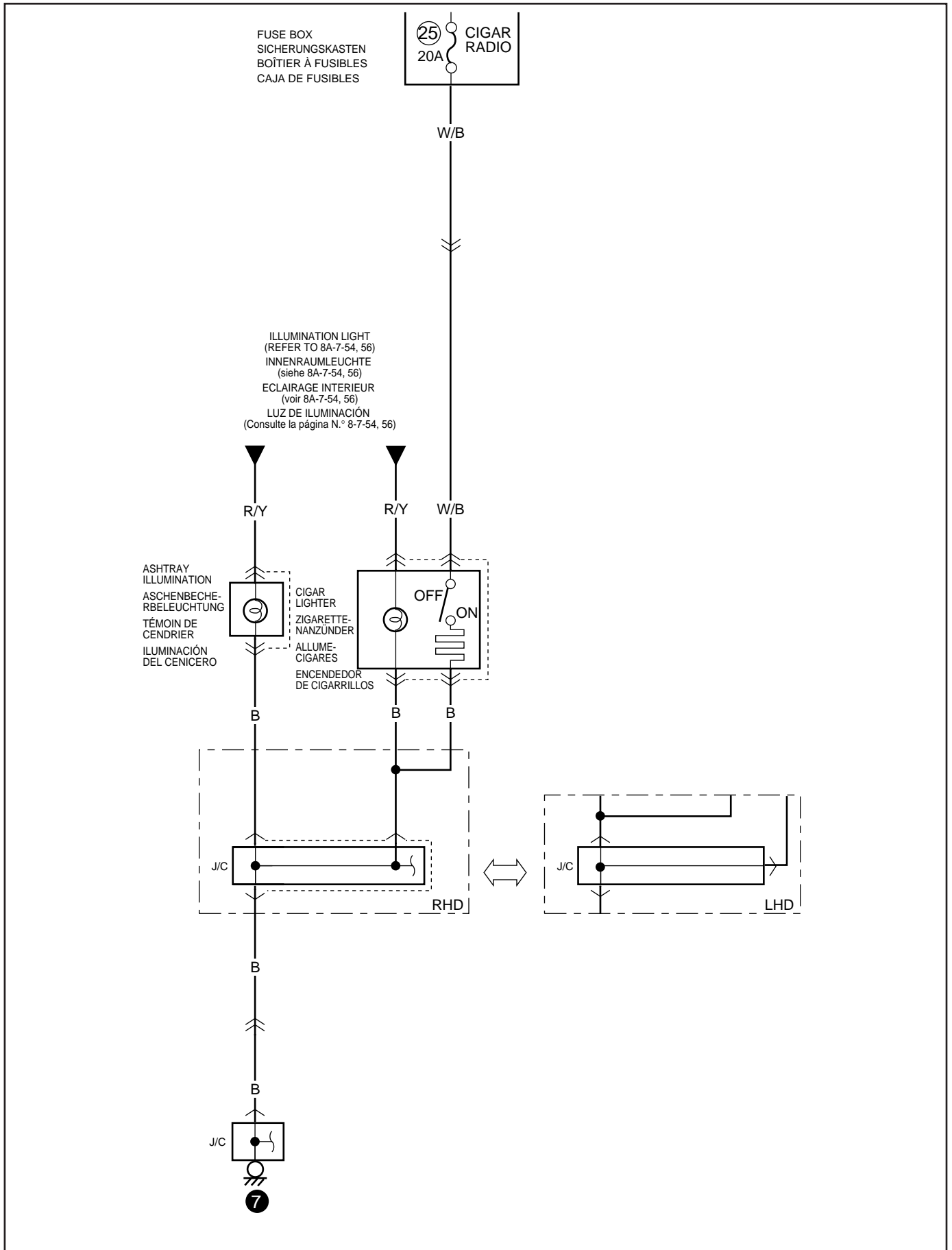

WARNING BUZZER
WARNSUMMER
VIBREUR D'AVERTISSEMENT
ZUMBADOR DE AVISO

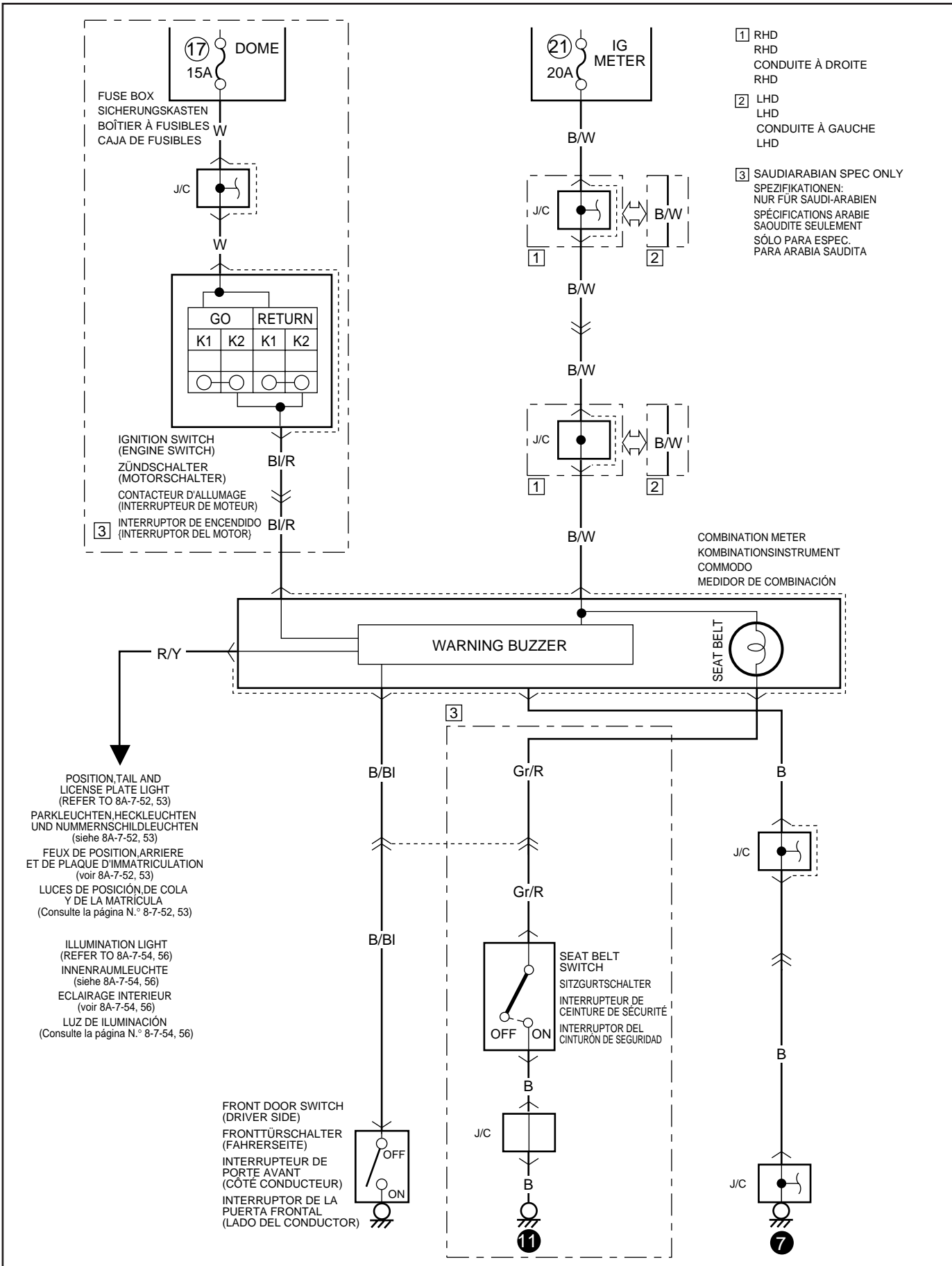

AIR-BAG CONTROL SYSTEM

AIRBAG-STEUERSYSTEM

SYSTÈME DE COMMANDE DES AIRBAGS

SISTEMA DE CONTROL DEL COLCHÓN DE AIRE

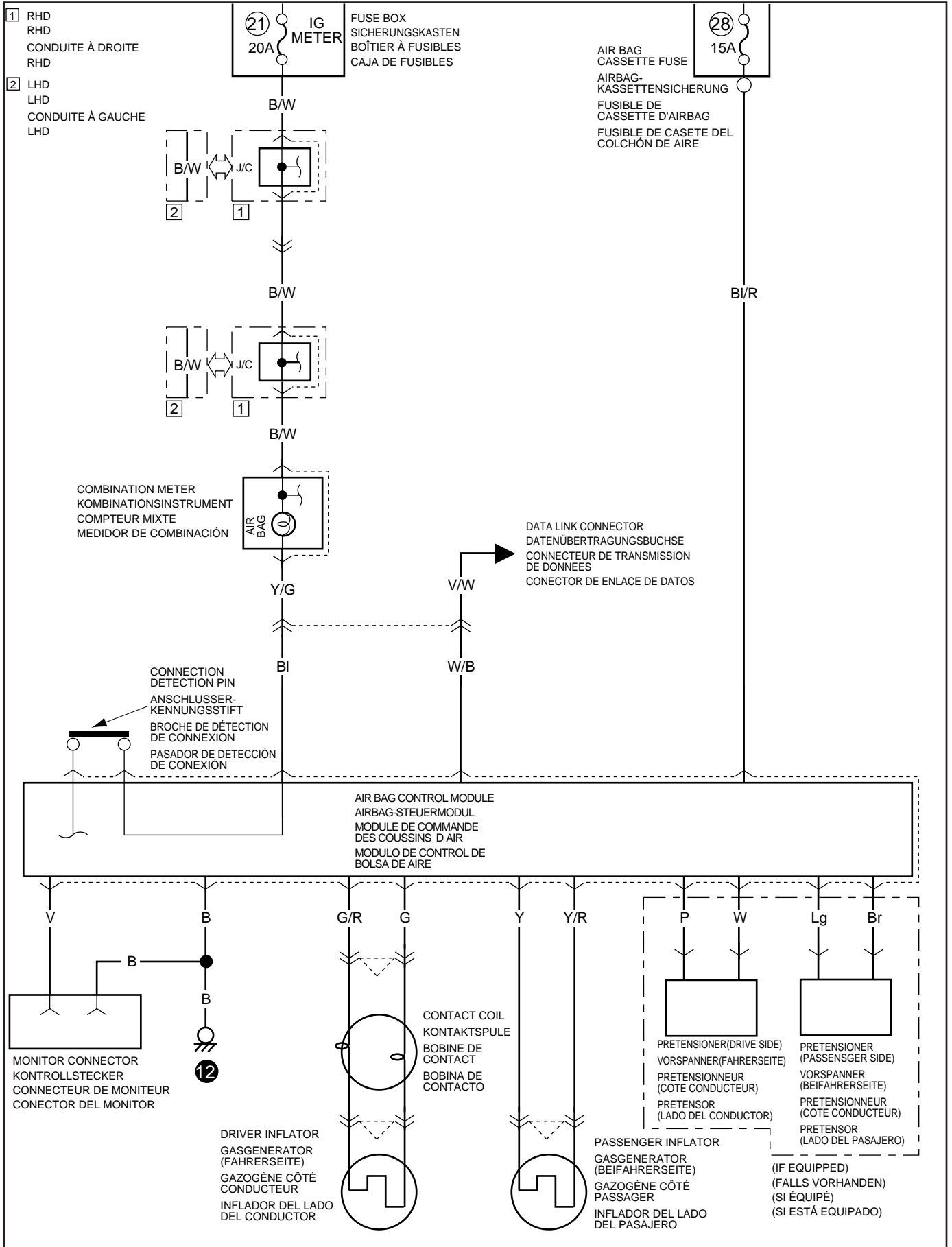

MEMO
NOTIZEN
NOTE
NOTAS

ANTI-LOCK BRAKE SYSTEM
ANTIBLOCKIERSYSTEM
SYSTÈME D'ANTIBLOCAGE DES FREINS
SISTEMA DE FRENOS ANTIENCLAVAMIENTO

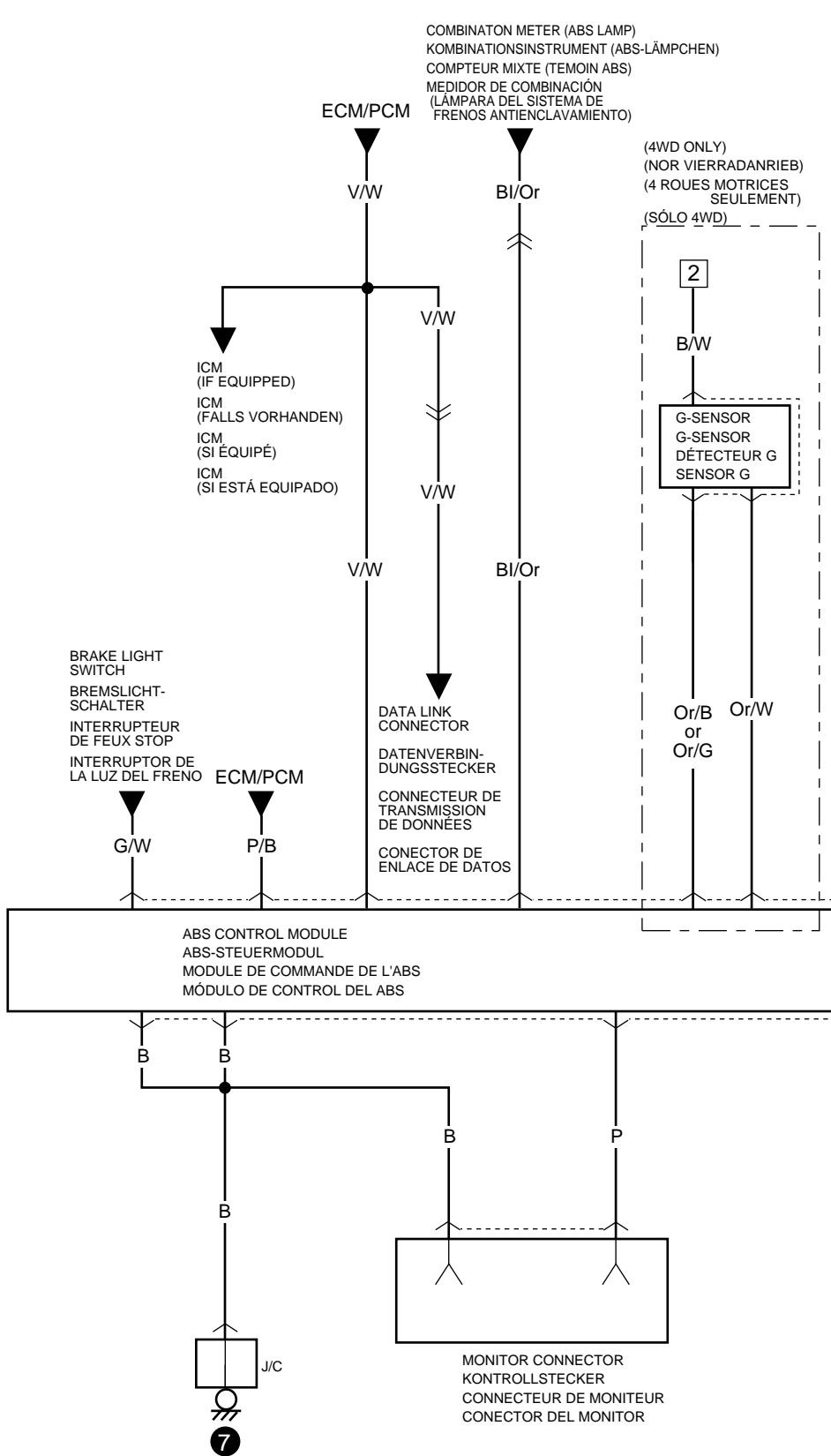

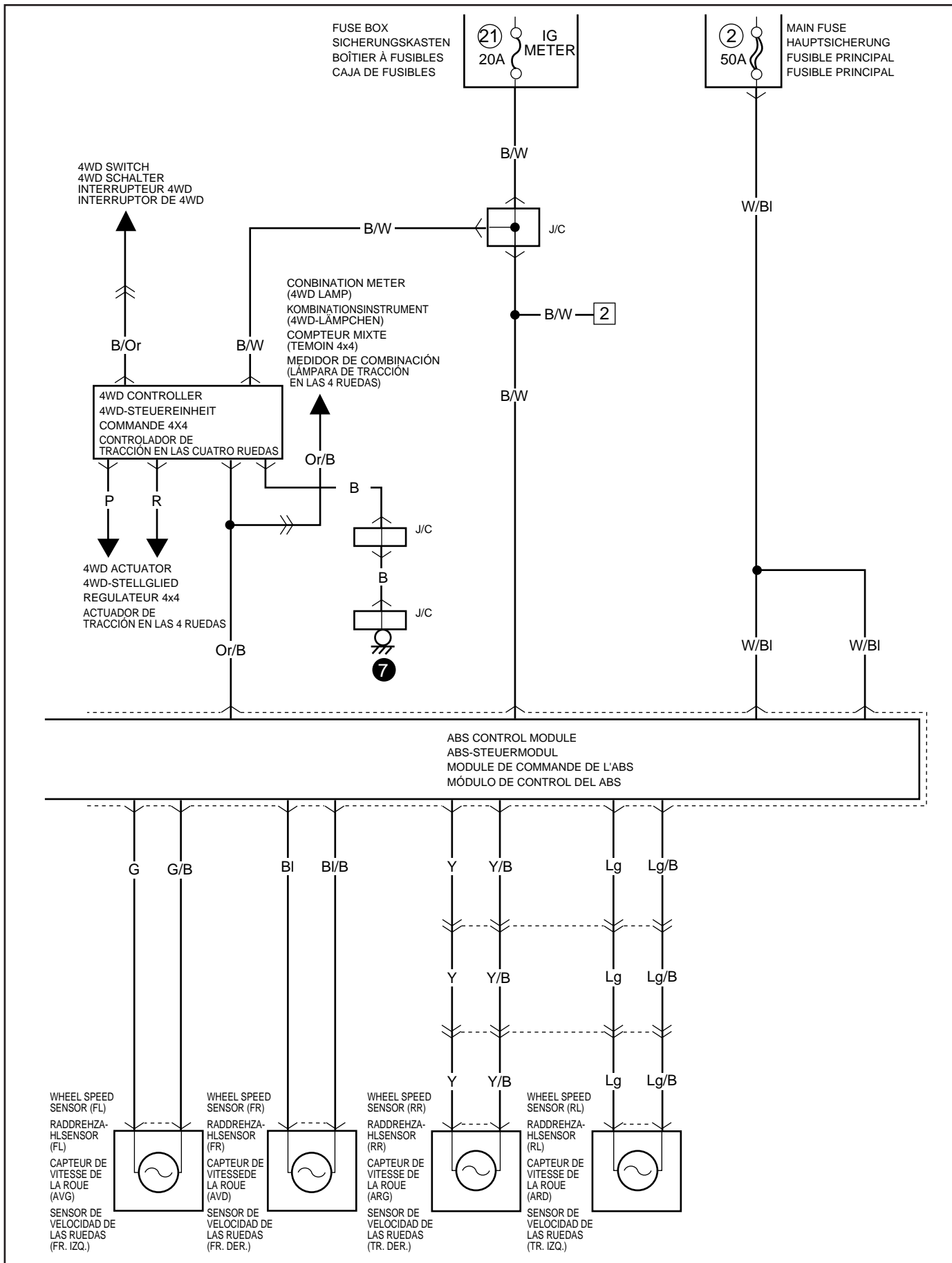

REAR FOG LIGHT
HECKNEBELLEUCHTE
ANTIBROUILLARD ARRIÈRE
LUZ ANTINEBLA TRASERA

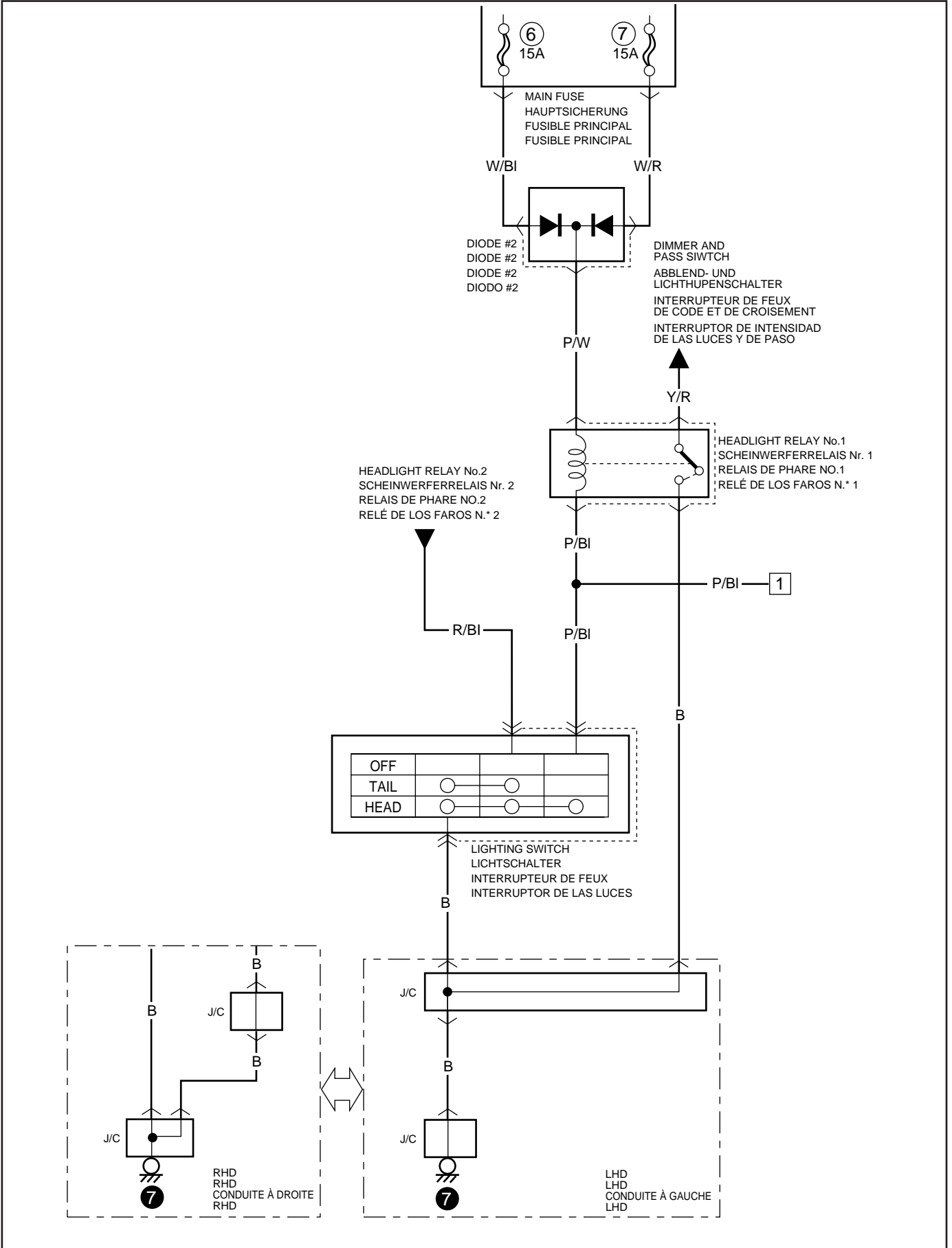

HEADLIGHT BEAM LEVELING SYSTEM
SCHEINWERFERSTRAHL-NIVELLIERSYSTEM
SYSTÈME DE RÉGLAGE DES FAISCEAUX DE PHARES
SISTEMA DE NIVELACIÓN DEL HAZ DE LUZ DE LOS FAROS

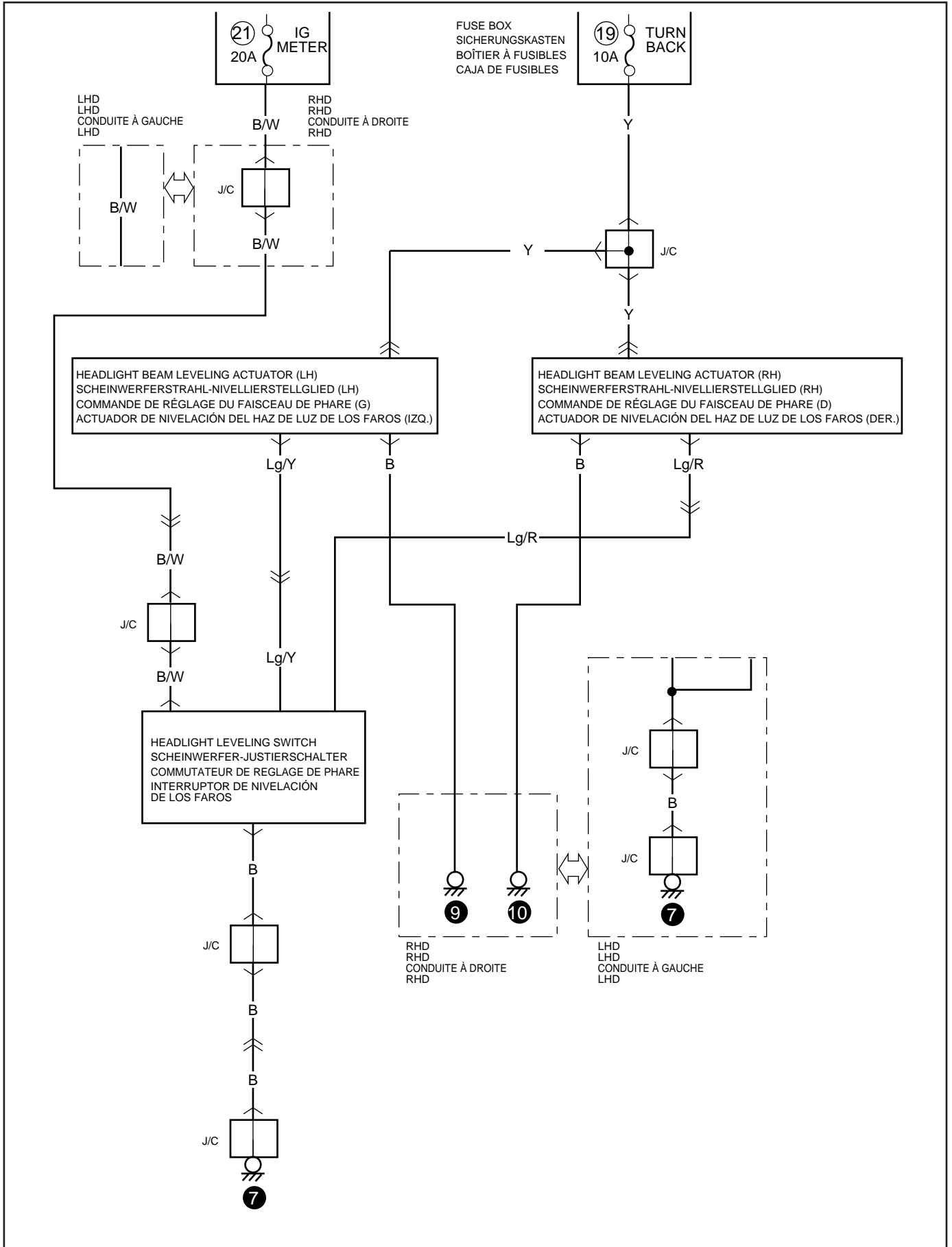

GROUP 2 GRUPPE 2 GROUPE 2 GRUPO 2

SQ416/SQ420/

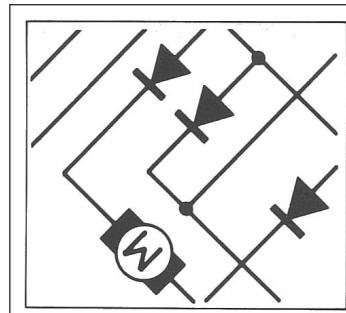

**SUPPLEMENTARY WIRING DIAGRAM MAUAL
NACHTRAG ZUM STROMLAUFPLAN-HANDBUCH
MANUEL DE SCHEMA DE CABLAGE SUPPLEMENTAIRE
MANUAL CON EL DIAGRAMA DE CABLEADO SUPLEMENTARIO**

**FOR CANVAS TOP MODEL
FÜR MODELLE MIT FALTDACH
POUR MODELE A CAPOTE EN TOILE
PARA EL MODELO CON CAPOTA**

FOREWORD

This SUPPLEMENTARY SERVICE MANUAL (GROUP 2) is a supplement to GROUP 1. Therefore, whenever servicing applicable model, consult GROUP 2 first. And for any section, item or description not found in GROUP 2, refer to GROUP 1.

Diese ERGÄNZUNG ZUR WARTUNGSANLEITUNG (GRUPPE 2) ist einer Ergänzung zu GRUPPE 1. Daher ist für die Wartung des zutreffenden Modells zuerst die GRUPPE 2 zu beachten. Für nicht in GRUPPE 2 aufgefundene Abschnitte, Punkte oder Beschreibungen siehe GRUPPE 1.

CE SUPPLÉMENT DE MANUEL D'ENTRETIEN (GROUPE 2) est le supplément du GROUPE 1. Par conséquent, lorsque des opérations d'entretien sont effectuées sur un modèle applicable, consultez d'abord les descriptions du GROUPE 2. Et pour toutes les descriptions qui n'apparaissent pas dans le GROUPE 2, consultez les descriptions du GROUPE 1.

Este MANUAL DE SERVICIO SUPLEMENTARIO (GRUPO 2) es un suplemento para el GRUPO 1. Por lo tanto, siempre que efectúe el servicio a un modelo aplicable, consulte primero el GRUPO 2. Para cualquier sección, ítem o descripción que no se encuentre en el GRUPO 2, consulte el GRUPO 1.

Applicable model :

Betreffendes Modell :

Modél couvert :

Modelo aplicable :

SQ416Q (X)2S2GTA03C00100001(X)~
(X)2S2GTA03CX0100001(X)~
SQ420Q (X)2S2GTA52C00100001(X)~
(X)2S2GTA52CX0100001(X)~
2S3TA52C X6100001~

SUZUKI MOTOR CORPORATION
OVERSEAS SERVICE DEPARTMENT

TABLE OF CONTENTS

SECTION

POWER SUPPLY DIAGRAM
STROMVERSORGUNGSDIAGRAMM
SCHÉMA DU CIRCUIT D'ALIMENTATION
DIAGRAMA DE LA ALIMENTACIÓN ELÉCTRICA

8A-6

SYSTEM CIRCUIT DIAGRAM
SYSTEMSCHALTDIAGRAMM
SCHÉMA DES SYSTÈMES ÉLECTRIQUES
DIAGRAMA DEL CIRCUITO DEL SISTEMA

8A-7

RELATED SERVICE MANUAL

Refer to FOREWORD of GROUP 1.

ZUTREFFENDE WARTUNGSANLEITUNG

Siehe VORWORT in GRUPPE 1.

MANUEL D'ENTRETIEN CONNEXE

Se référer à l'AVANT-PROPOS du GROUPE 1.

MANUAL DE SERVICIO RELACIONADO

Consulte la INTRODUCCIÓN del GRUPO 1.

SECTION 8A-6
ABSCHNITT 8A-6
SECTION 8A-6
SECCIÓN 8A-6

POWER SUPPLY DIAGRAM
STROMVERSORGUNGSDIAGRAMM
SCHÉMA DU CIRCUIT D'ALIMENTATION
DIAGRAMA DE ALIMENTACIÓN ELÉCTRICA

CONTENTS
INHALT
TABLE DES MATIÈRES
ÍNDICE

· POWER SUPPLY DIAGRAM.....	8A-6-2
· MAIN FUSE	8A-6-3
· JUNCTION FUSE BLOCK	8A-6-3
· STROMVERSORGUNGSDIAGRAMM.....	8A-6-2
· HAUPTSICHERUNG	8A-6-3
· ABZWEIGSICHERUNGSBLOCK	8A-6-3
· SCHÉMA DU CIRCUIT D'ALIMENTATION.....	8A-6-2
· FUSIBLE PRINCIPAL	8A-6-3
· BLOC FUSIBLE DE JONCTION	8A-6-3
· DIAGRAMA DE ALIMENTACIÓN ELÉCTRICA.....	8A-6-2
· FUSIBLE PRINCIPAL	8A-6-3
· BLOQUE DE FUSIBLES DE UNIÓN	8A-6-3

POWER SUPPLY DIAGRAM
STROMVERSORUNGSDIAGRAMM
SCHEMA DU CIRCUIT D'ALIMENTATION
DIAGRAMA DE ALIMENTACIÓN ELÉCTRICA

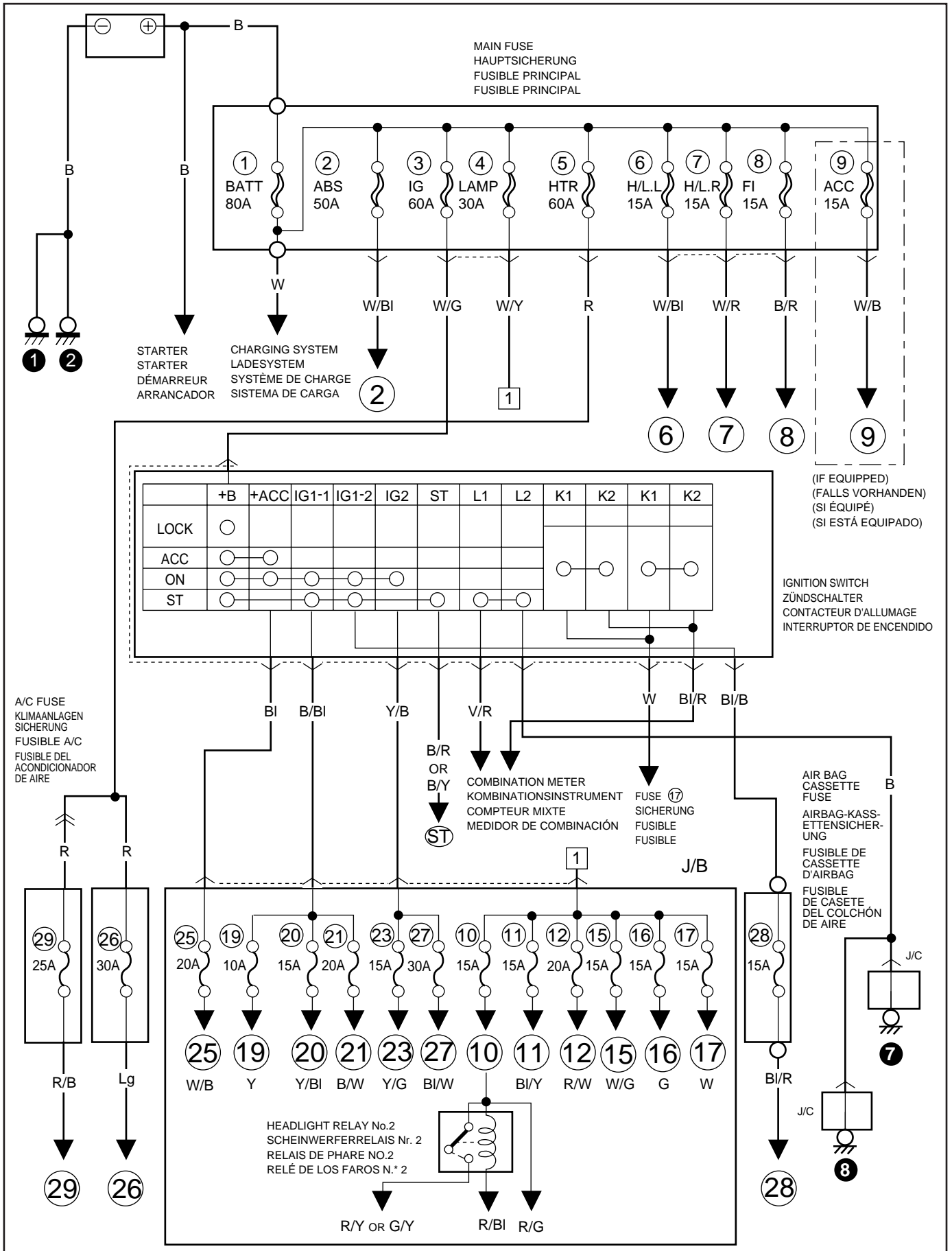

**MAIN FUSE
 HAUPTSICHERUNG
 FUSIBLE PRINCIPAL
 FUSIBLE PRINCIPAL**

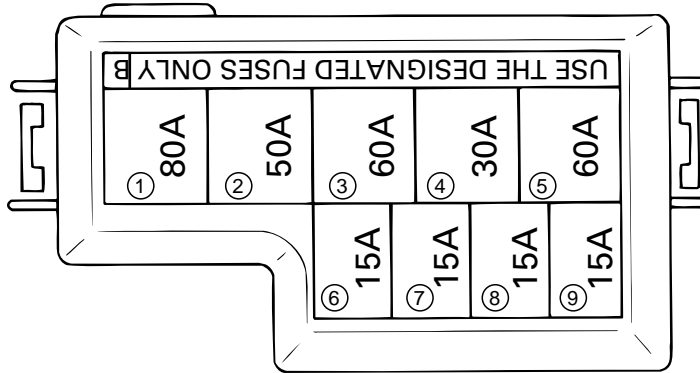

**JUNCTION FUSE BLOCK
 ABZWEIGSICHERUNGSBLOCK
 BLOC FUSIBLE DE JONCTION
 BLOQUE DE FUSIBLES DE UNIÓN**

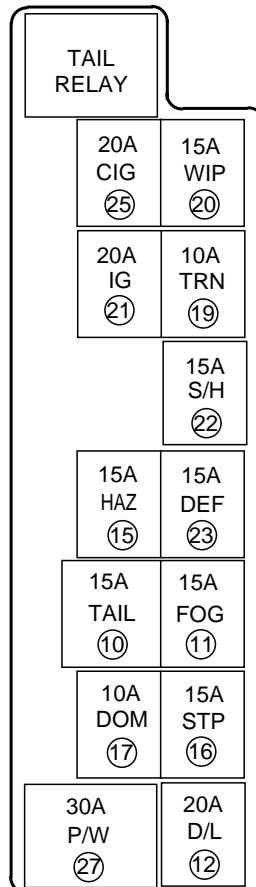

SECTION 8A-7

SYSTEM CIRCUIT DIAGRAM

CONTENTS

CRANKING SYSTEM	8A-7-9
CHARGING SYSTEM	8A-7-10
IMMOBILIZER CONTROL SYSTEM	8A-7-11
IGNITION, ENGINE & EMISSION CONTROL SYSTEM	8A-7-12
4WD CONTROL SYSTEM	8A-7-13
WINDSHIELD WIPER & WASHER	8A-7-14
POWER WINDOW	8A-7-15
POWER DOOR LOCK	8A-7-16
REMOTE CONTROLLED MIRROR	8A-7-18
HORN	8A-7-19
METER & GAUGE WARNING BUZZER	8A-7-20
INDICATOR LAMP	8A-7-21
WARNING LAMP	8A-7-22
HEADLIGHT SYSTEM (VEHICLE WITHOUT DRL)	8A-7-24
HEADLIGHT SYSTEM (VEHICLE WITH DRL)	8A-7-26
POSITION, TAIL AND LICENSE PLATE LIGHT	8A-7-28
ILLUMINATION LAMP	8A-7-30
ROOM LIGHT (CANVAS TOP)	8A-7-31
TURN SIGNAL AND HAZARD WARNING LIGHT	8A-7-32
BRAKE LIGHT	8A-7-34
BUCK-UP LAMP	8A-7-35
HEATER AND AIR CONDITIONING	8A-7-36
RADIO	8A-7-39

CLOCK.....	8A-7-40
CIGAR LIGHTER	8A-7-41
AIR-BAG CONTROL SYSTEM.....	8A-7-42
ANTI-LOCK BRAKE SYSTEM.....	8A-7-44
REAR FOG LIGHT.....	8A-7-46
HEADLIGHT BEAM LEVELING SYSTEM.....	8A-7-48

CRANKING SYSTEM
KURBELSYSTEM
SYSTÈME DE DÉMARRAGE
SISTEMA DE ARRANQUE

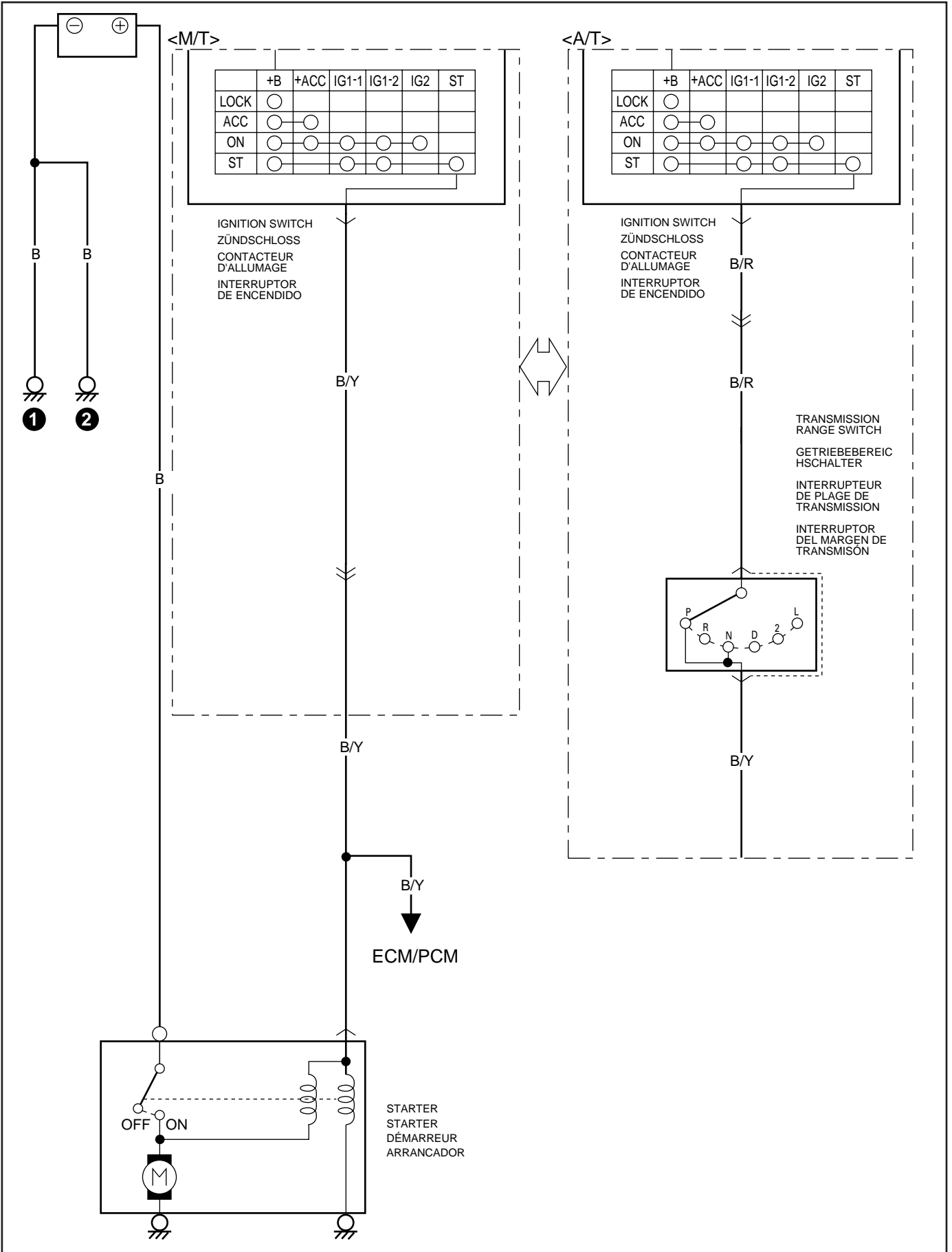

CHARGING SYSTEM
LADESYSTEM
SYSTÈME DE CHARGE
SISTEMA DE CARGA

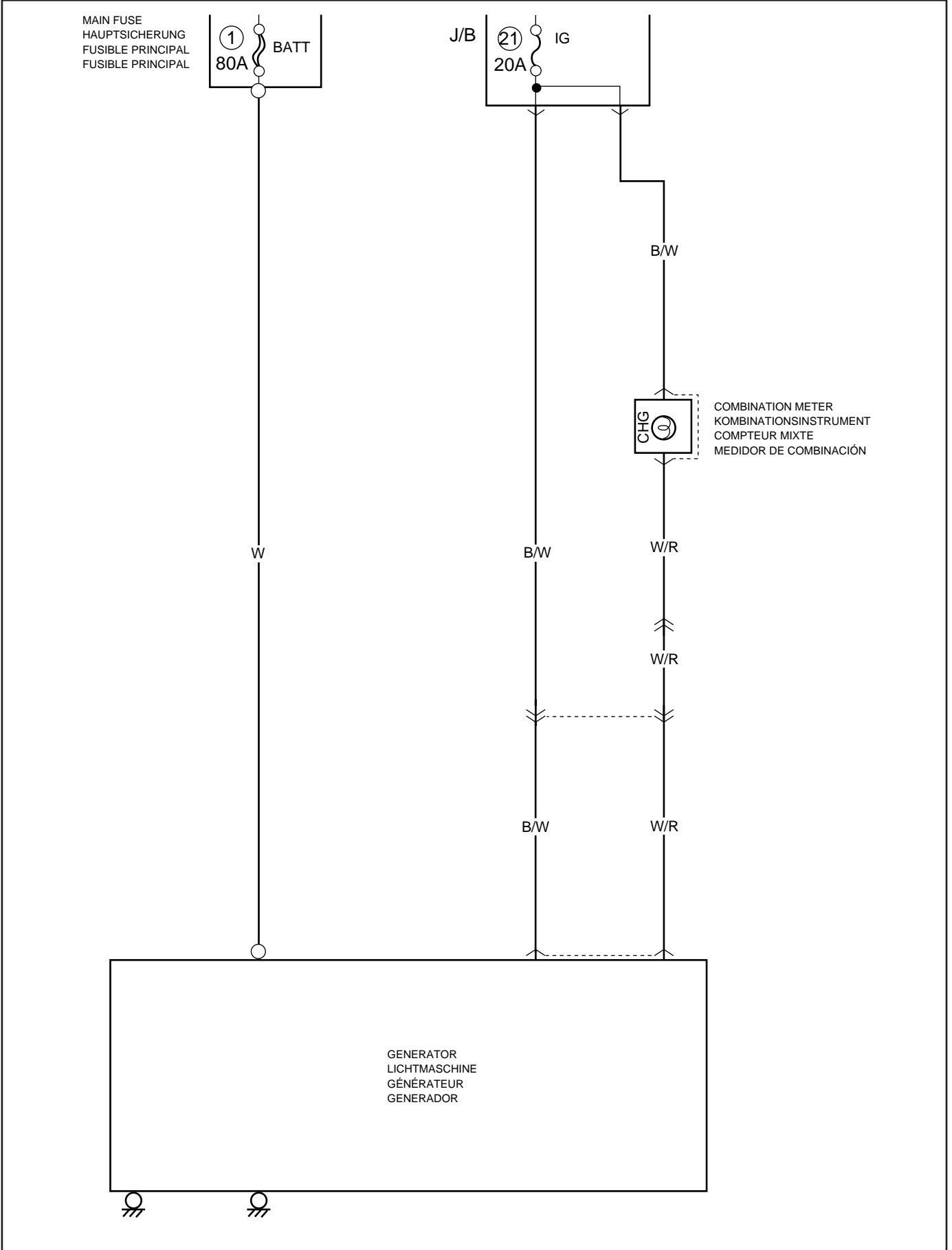

IMMOBILIZER CONTROL SYSTEM
WEGFAHRSPERRE-STEUERSYSTEM
SYSTÈME DE COMMANDE DE L'IMMOBILISATEUR
SISTEMA DE CONTROL DEL INMOVILIZADOR

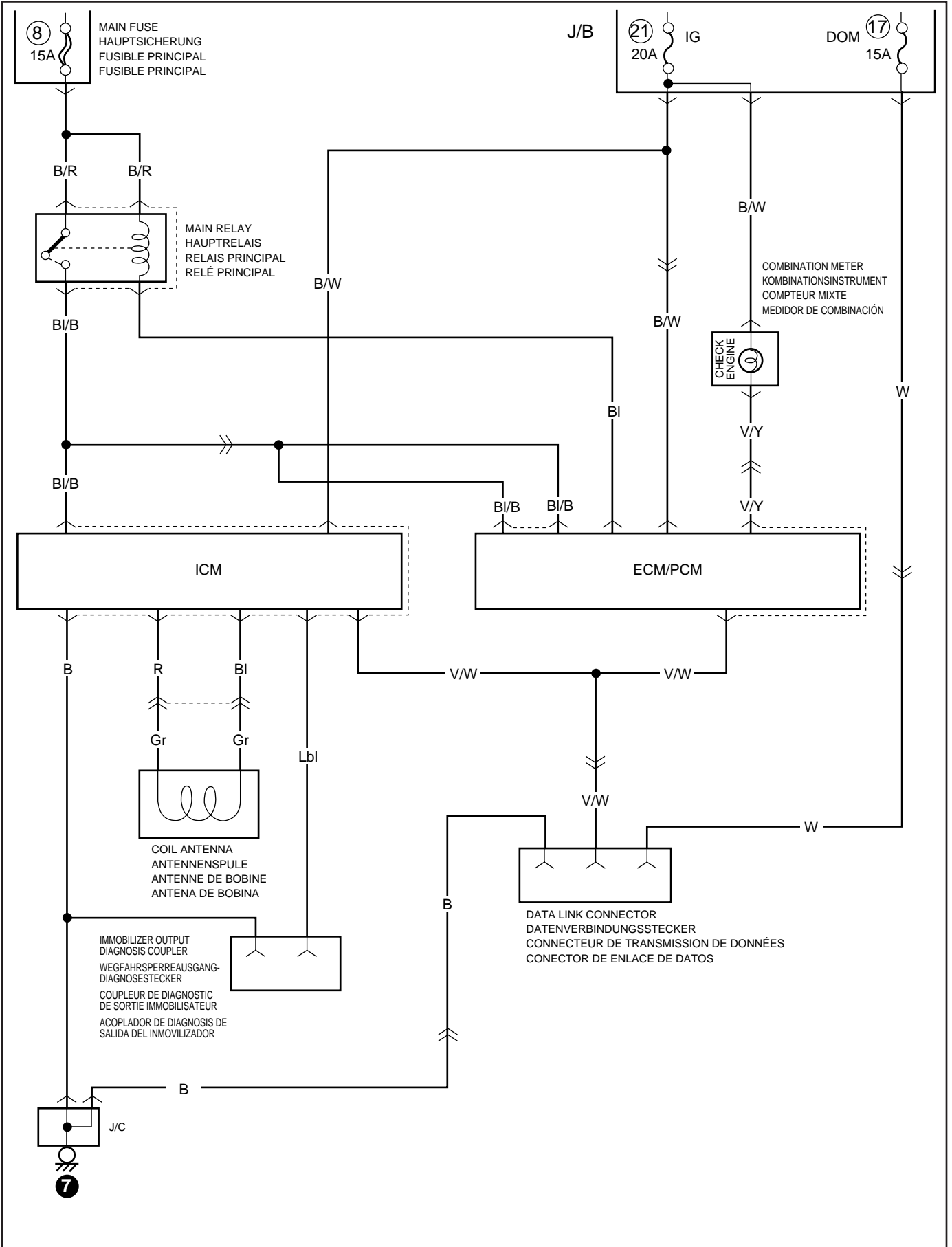

IGNITION, ENGINE & EMISSION CONTROL SYSTEM**ZÜNDUNGS-, MOTOR- UND ABGASREGELSYSTEM****SYSTEME DE COMMANDE DE L'ALLUMAGE, MOTEUR ET GAZ D'ÉCHAPPEMENT****SISTEMA DE ENCENDIDO, MOTOR Y CONTROL DE EMISIONES**

Refer to 8A-7-12 through 8A-7-21 noting the following difference :

1. Joint connectors (J/C) are not used in this model but wires are connected directly.
Please neglect all the description of the joint connectors (J/C).
2. Junction fuse block (J/B) is used instead of "fuse box" in this model.
So please replace all the description of "fuse box" with junction fuse block (J/B).

Siehe 8A-7-12 bis 8A-7-21, wobei die folgenden Unterschiede zu beachten sind :

1. Verbindungsstecker (J/C) werden in diesem Modell nicht verwendet, da die Drähte direkt angeschlossen sind.
Bitte alle Beschreibungen der Verbindungsstecker (J/C) nicht beachten.
2. Der Abzweigsicherungsblock (J/B) wird in diesem Modell anstelle des "Sicherungskastens" verwendet.
Daher alle Beschreibungen des "Sicherungskastens" durch den Abzweigsicherungsblock (J/B) ersetzen.

Se référer de 8A-7-12 à 8A-7-21 tout en notant les différences suivantes :

1. Aucun bloc raccord de câblage de jonction (J/C) n'a été utilisé dans le présent modèle tandis que le branchement des fils a été réalisé directement.
Veuillez ignorer toutes les descriptions relatives aux blocs raccord de câblage de jonction (J/C).
2. Le bloc fusible de jonction (J/B) est utilisé à la place d'une "boîte de servitude" dans le présent modèle.
Par conséquent, veuillez remplacer toutes les descriptions relatives à la "boîte de servitude" par celles du bloc fusible de jonction (J/B).

Consulte de 8A-7-12 a 8A-7-21 teniendo en cuenta la diferencia siguiente :

1. En este modelo no se emplean conectores de unión (J/C) sino que los cables se conectan directamente.
Pase por alto la descripción de los conectores de unión (J/C).
2. En este modelo se emplea el bloque de fusibles de unión (J/B) en lugar de la "caja de fusibles".
Por lo tanto, reemplace todas las descripciones de "caja de fusibles" por la de bloque de fusibles (J/B).

4WD CONTROL SYSTEM
4WD STEUERSYSTEM
SYSTEME DE COMMANDE 4WD
SISTEMA DE CONTROL DE TRACCIÓN EN LAS CUATRO RUEDAS

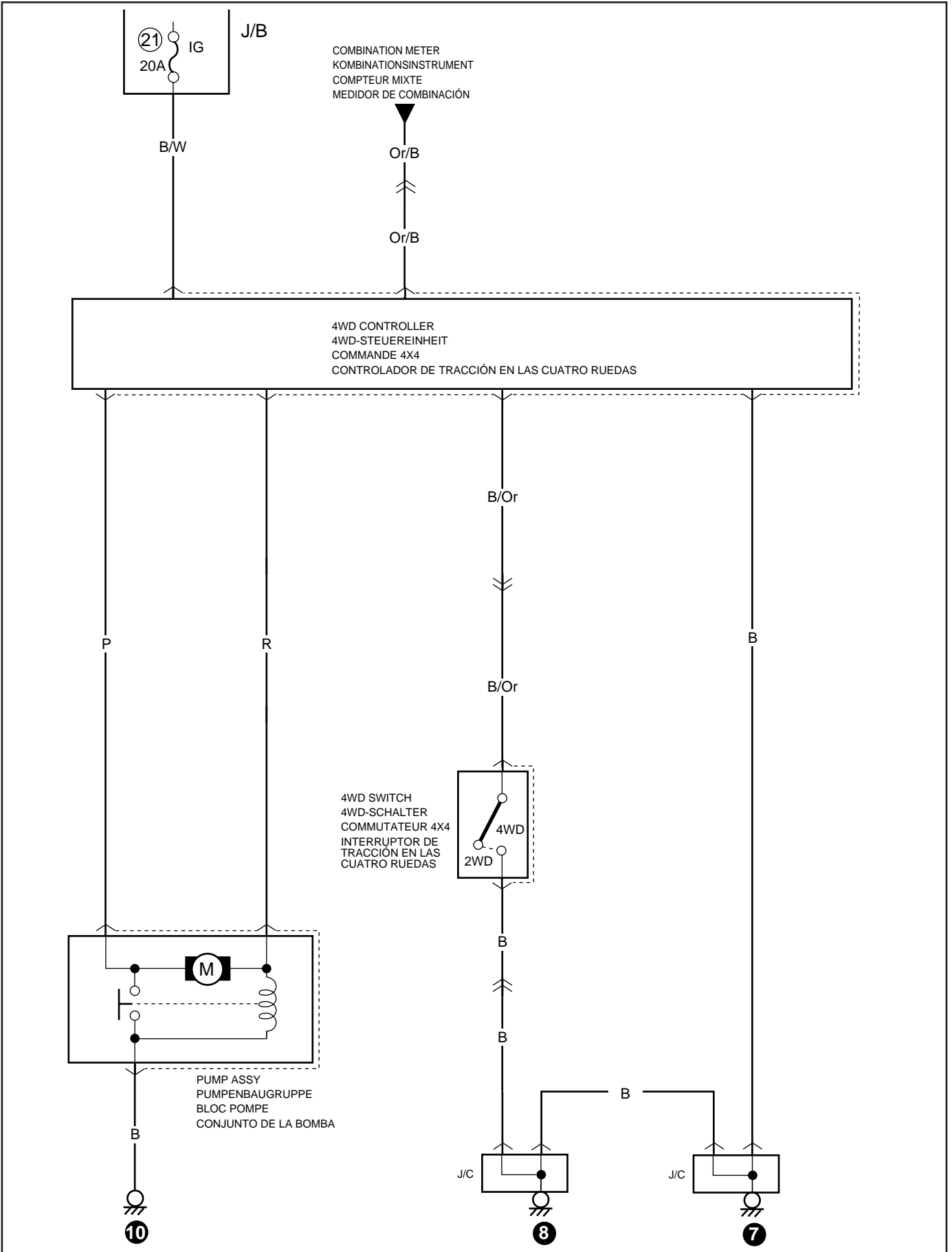

WINDSHIELD WIPER & WASHER
FRONTSCHWEIBENWISCHER UND WASCHANLAGE
ESSUIE-GLACE ET LAVE-GLACE DE PARE-BRISE
LIMPIADOR Y LAVADOR DEL PARABRISAS

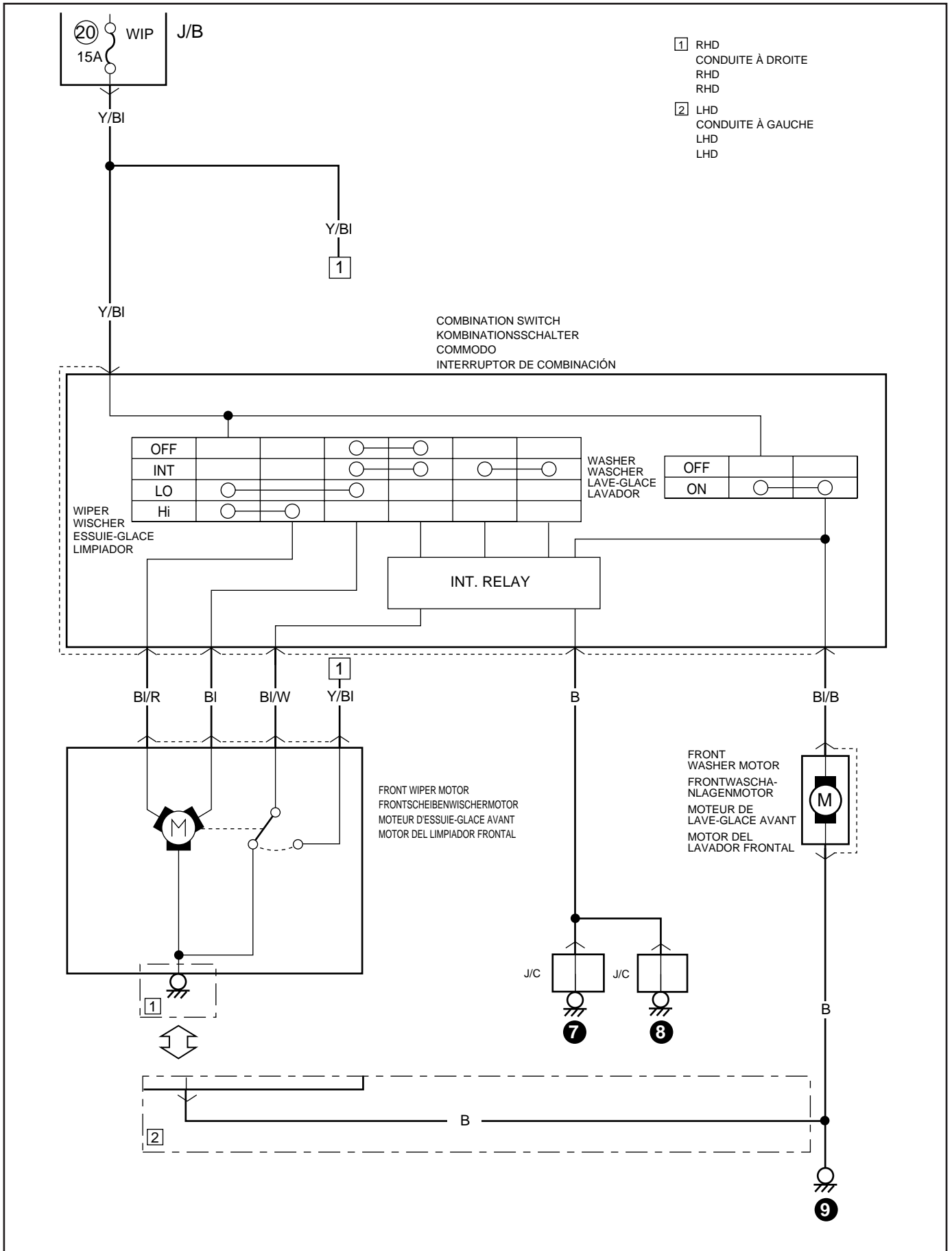

POWER WINDOW
AUTOMATISCHER FENSTERHEBER
LÈVE-VITRES ÉLECTRIQUES
VENTANILLA AUTOMÁTICA

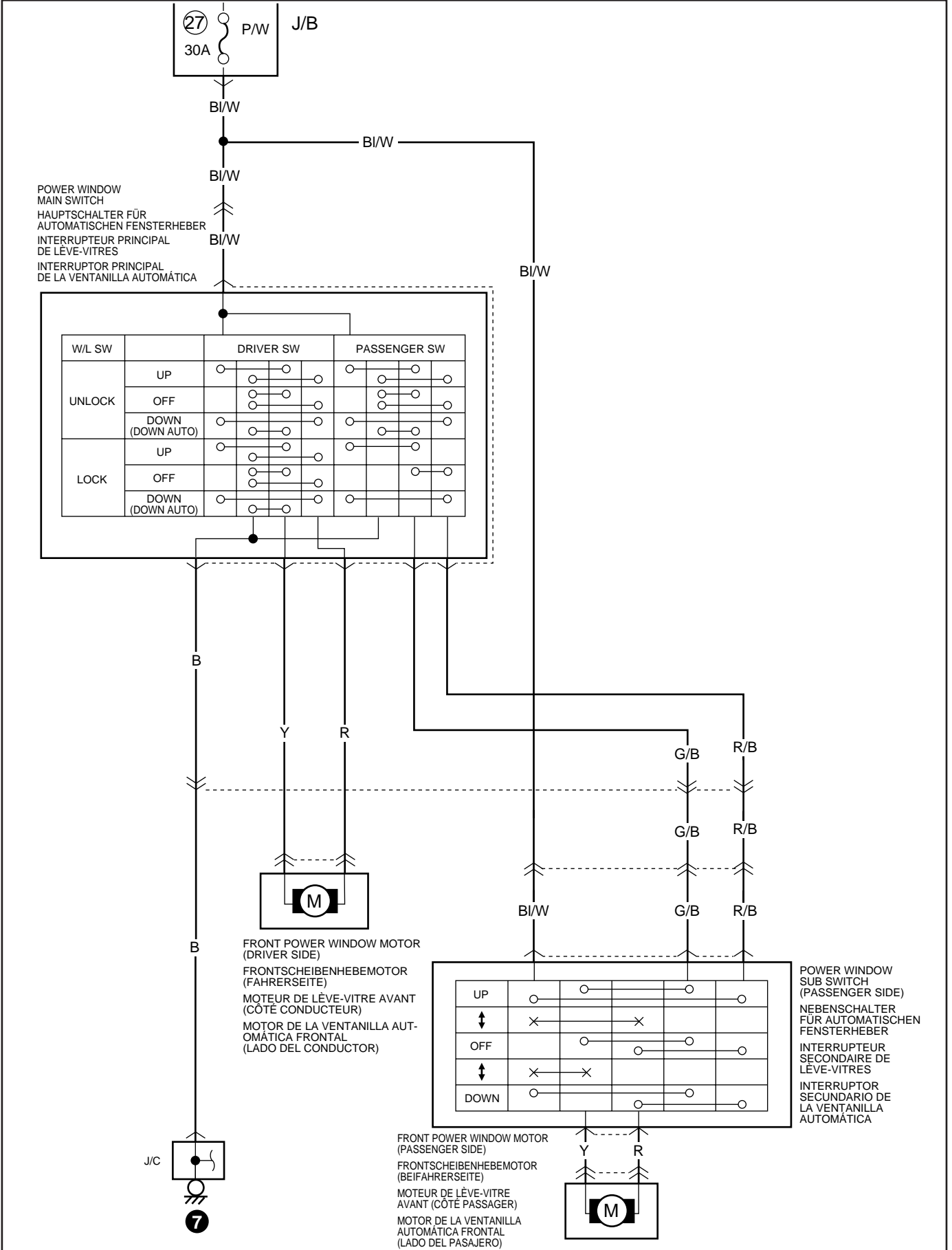

POWER WINDOW
 MAIN SWITCH
 HAUPTSCHALTER FÜR
 AUTOMATISCHEN FENSTERHEBER
 INTERRUPTEUR PRINCIPAL
 DE LÈVE-VITRES
 INTERRUPTOR PRINCIPAL
 DE LA VENTANILLA AUTOMÁTICA

W/L SW		DRIVER SW		PASSENGER SW	
UNLOCK	UP	○	○	○	○
	OFF	○	○	○	○
	DOWN (DOWN AUTO)	○	○	○	○
LOCK	UP	○	○	○	○
	OFF	○	○	○	○
	DOWN (DOWN AUTO)	○	○	○	○

FRONT POWER WINDOW MOTOR
 (DRIVER SIDE)
 FRONTSCHIEBENHEBEMOTOR
 (FAHRERSEITE)
 MOTEUR DE LÈVE-VITRE AVANT
 (CÔTÉ CONDUCTEUR)
 MOTOR DE LA VENTANILLA AUTOMÁTICA
 FRONTAL (LADO DEL CONDUCTOR)

UP	○	○	○	○
↕	×	×	×	×
OFF	○	○	○	○
↕	×	×	×	×
DOWN	○	○	○	○

POWER WINDOW
 SUB SWITCH
 (PASSENGER SIDE)
 NEBENSCHALTER
 FÜR AUTOMATISCHEN
 FENSTERHEBER
 INTERRUPTEUR
 SECONDAIRE DE
 LÈVE-VITRES
 INTERRUPTOR
 SECUNDARIO DE
 LA VENTANILLA
 AUTOMÁTICA

FRONT POWER WINDOW MOTOR
 (PASSENGER SIDE)
 FRONTSCHIEBENHEBEMOTOR
 (BEIFÄHRERSEITE)
 MOTEUR DE LÈVE-VITRE
 AVANT (CÔTÉ PASSAGER)
 MOTOR DE LA VENTANILLA
 AUTOMÁTICA FRONTAL
 (LADO DEL PASAJERO)

POWER DOOR LOCK
ELEKTRISCHE TÜRVERRIEGELUNG
VERROUILLAGE CENTRALISÉ DES PORTES
BLOQUEO AUTOMÁTICO DE LAS PUERTAS

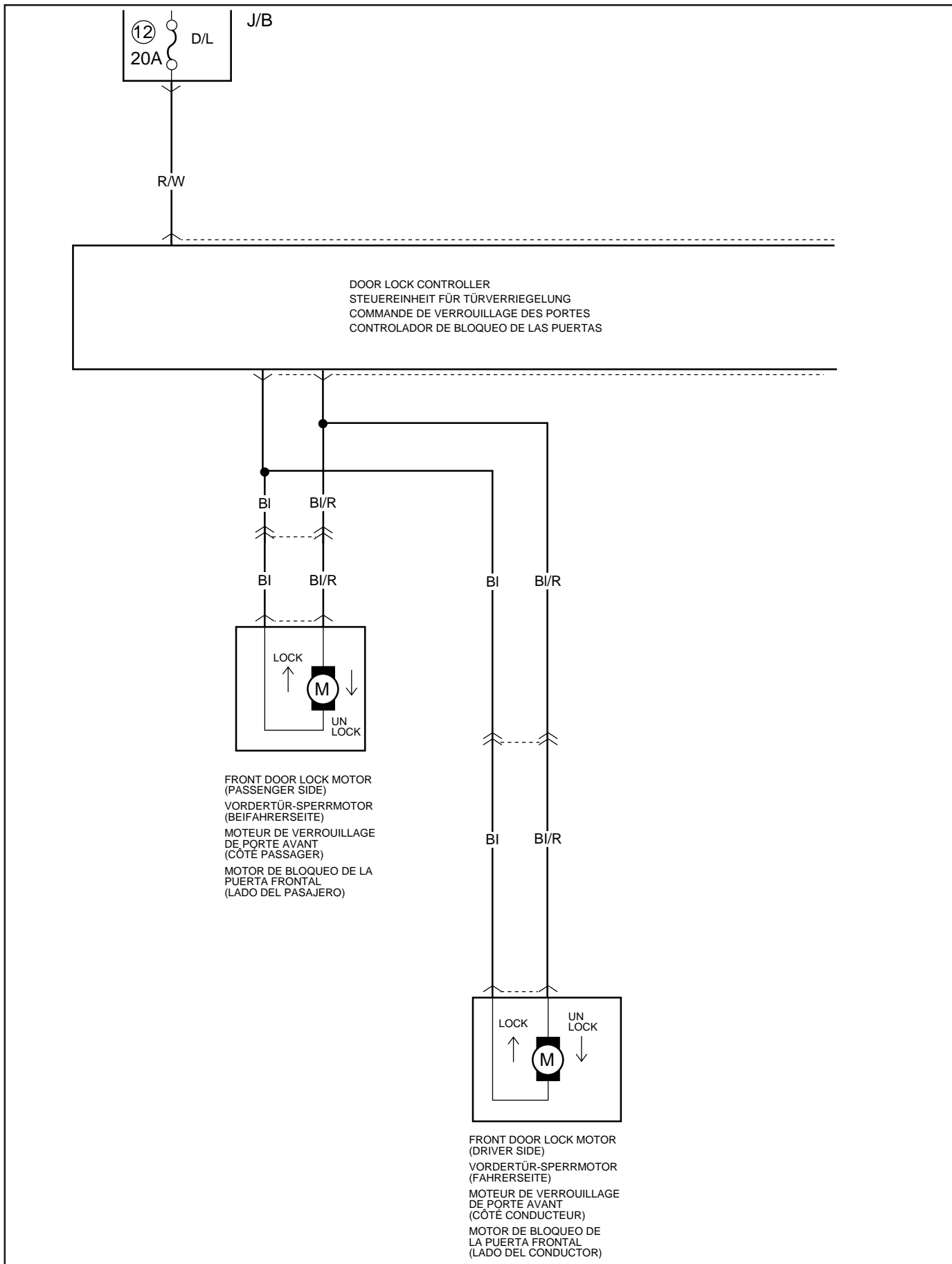

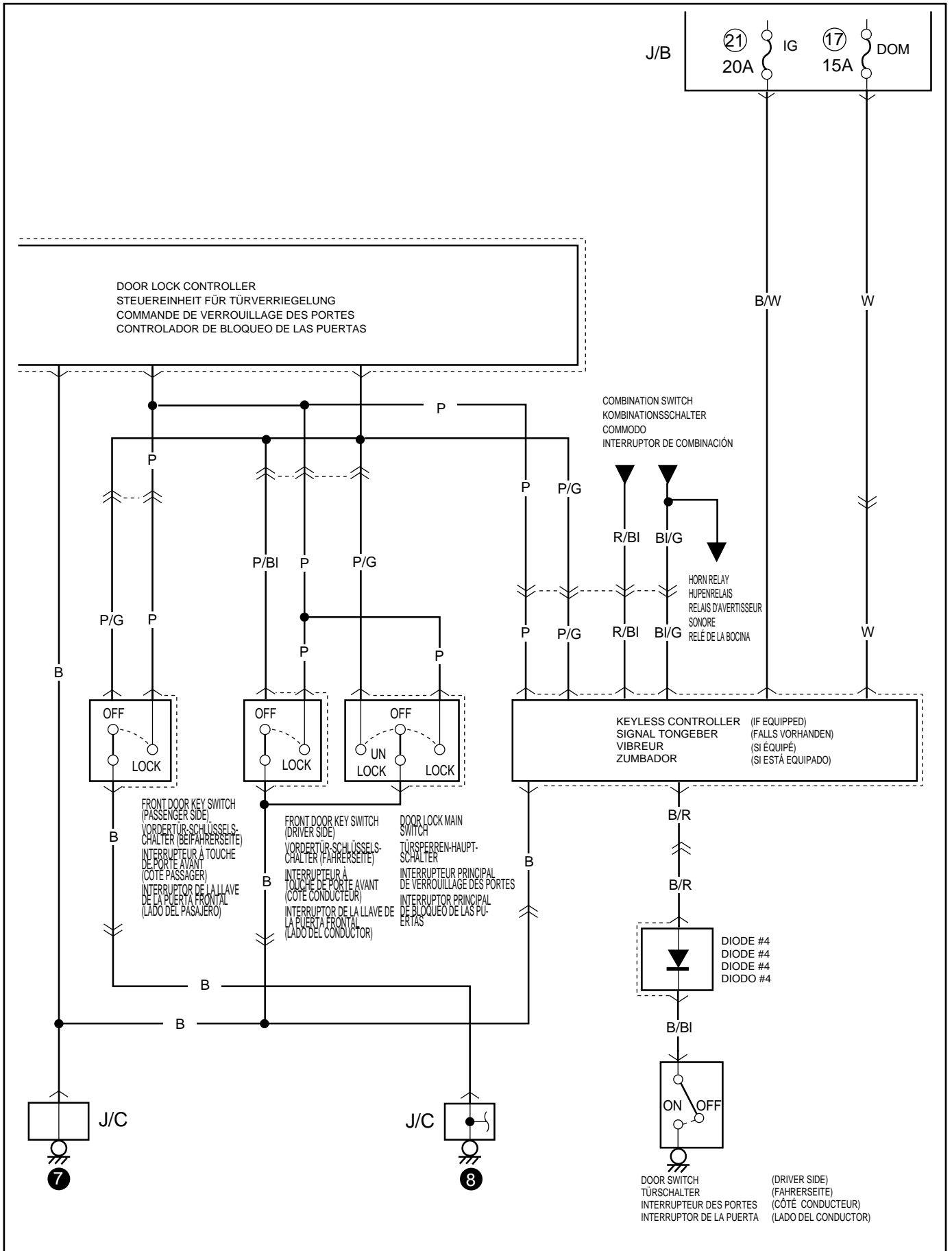

REMOTE CONTROLLED MIRROR
FERNBEDIENTER SPIEGEL
RÉTROVISEURS À COMMANDE À DISTANCE
ESPEJOS RETROVISORES DE CONTROL REMOTO

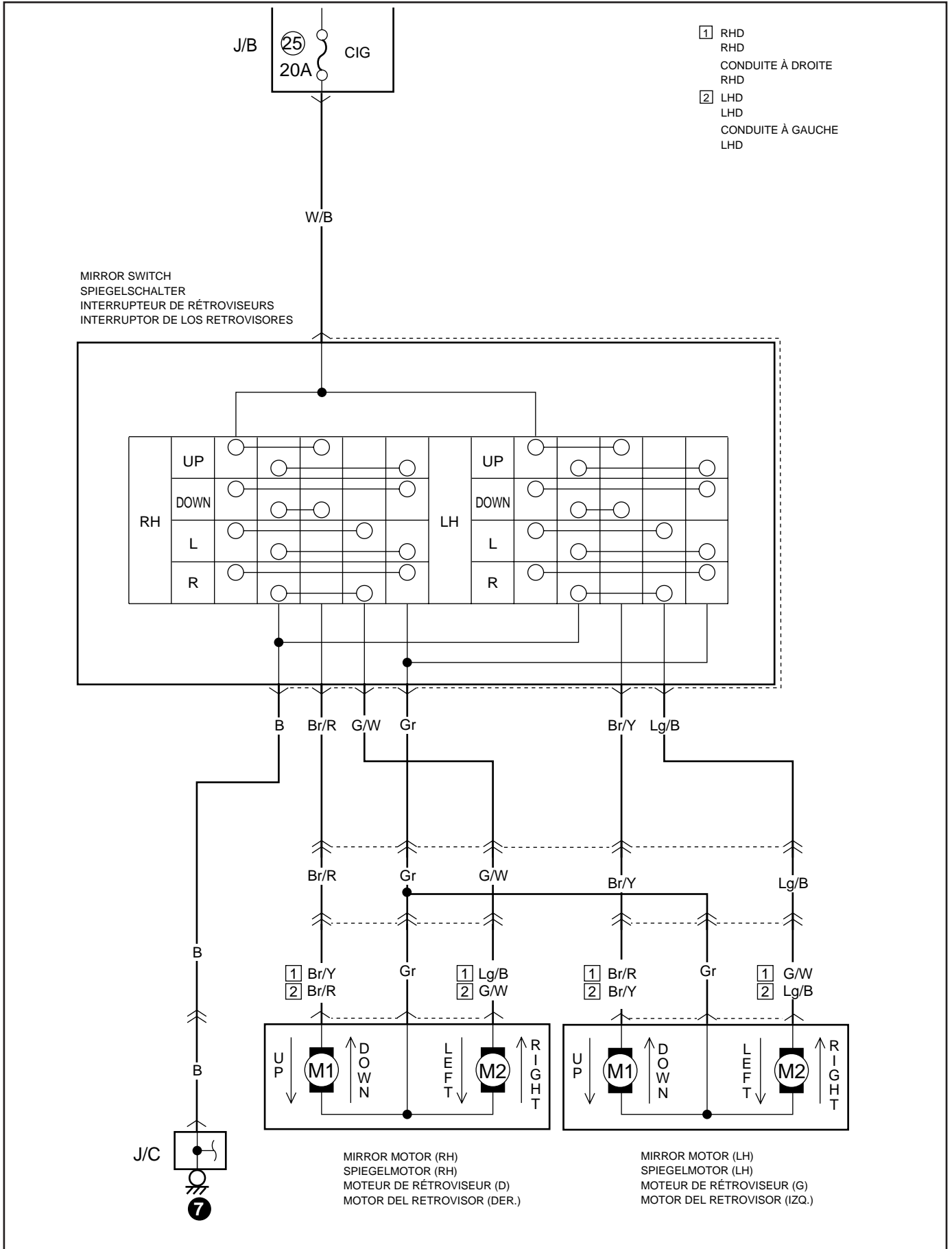

HORN
HUPE
AVERTISSEUR SONORE
BOCINA

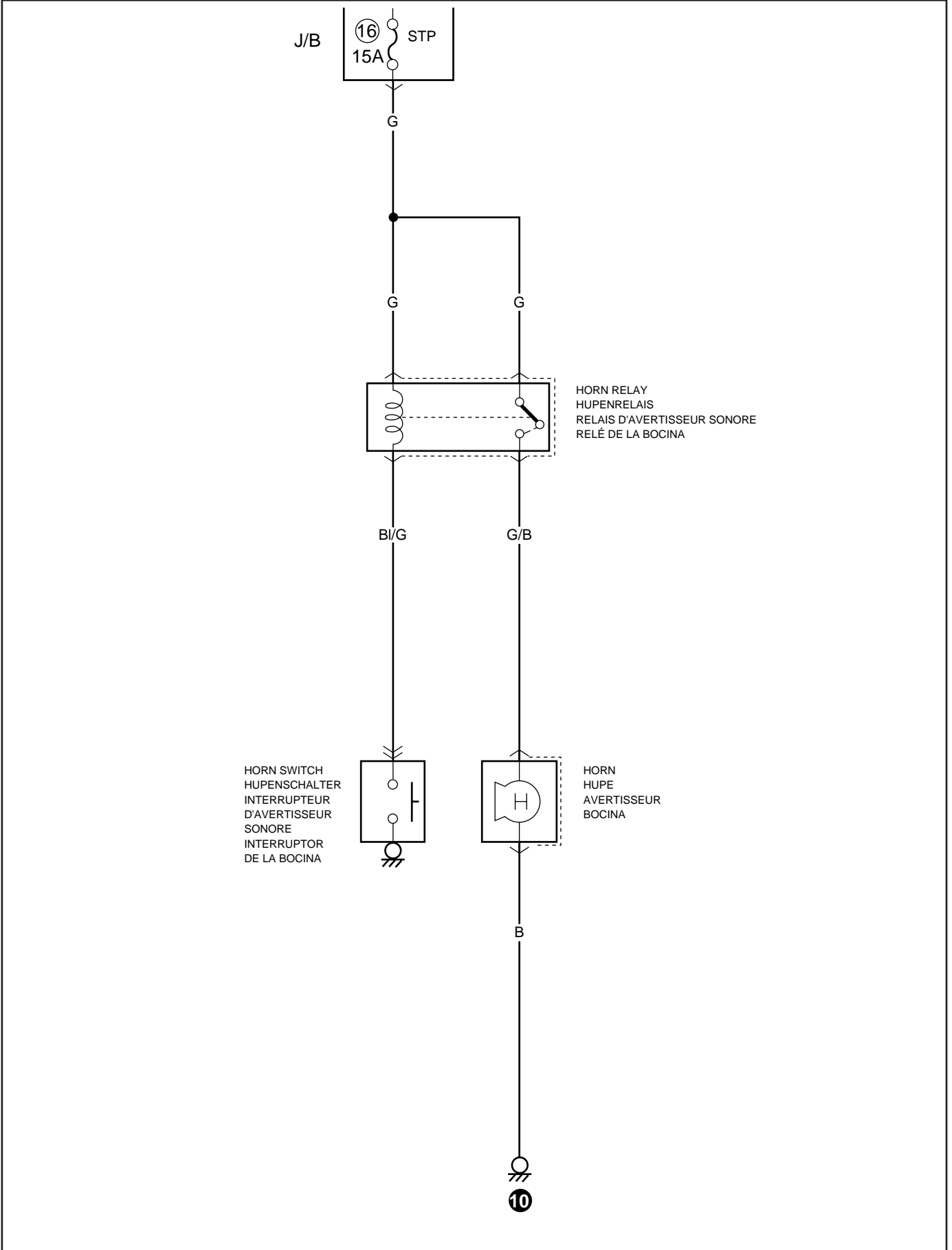

METER & GAUGE WARNING BUZZER
ANZEIGEINSTRUMENT & MESSUHR / WARNSUMMER
COMPTEUR ET JAUGE / AVERTISSEUR SONORE DE RAPPEL
MEDIDOR Y CONTADOR/ZUMBADOR DE ADVERTENCIA

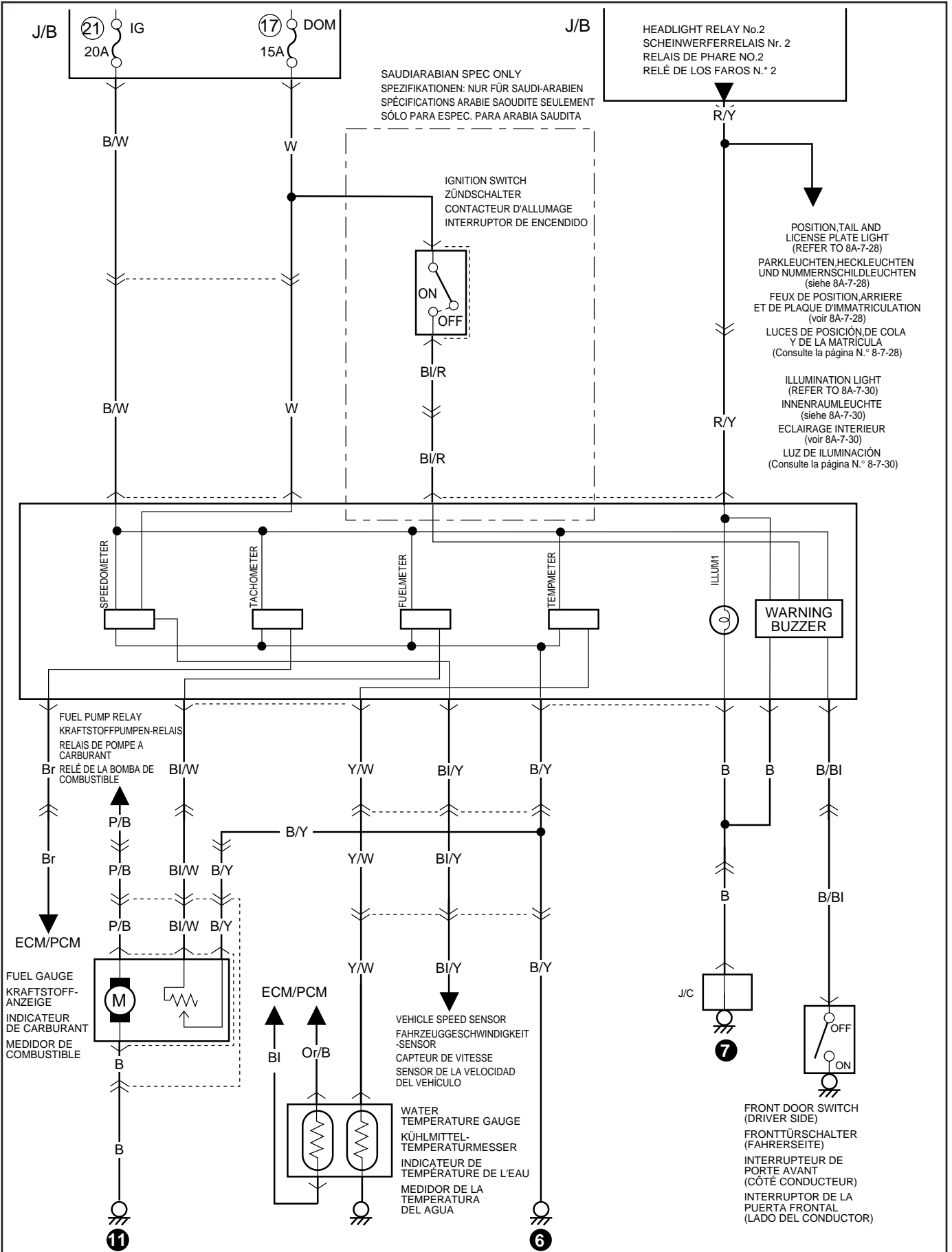

INDICATOR LAMP
 KONTROLLEUCHTE
 INDICATEURS TÉMOINS
 LÁMPARAS INDICADORAS

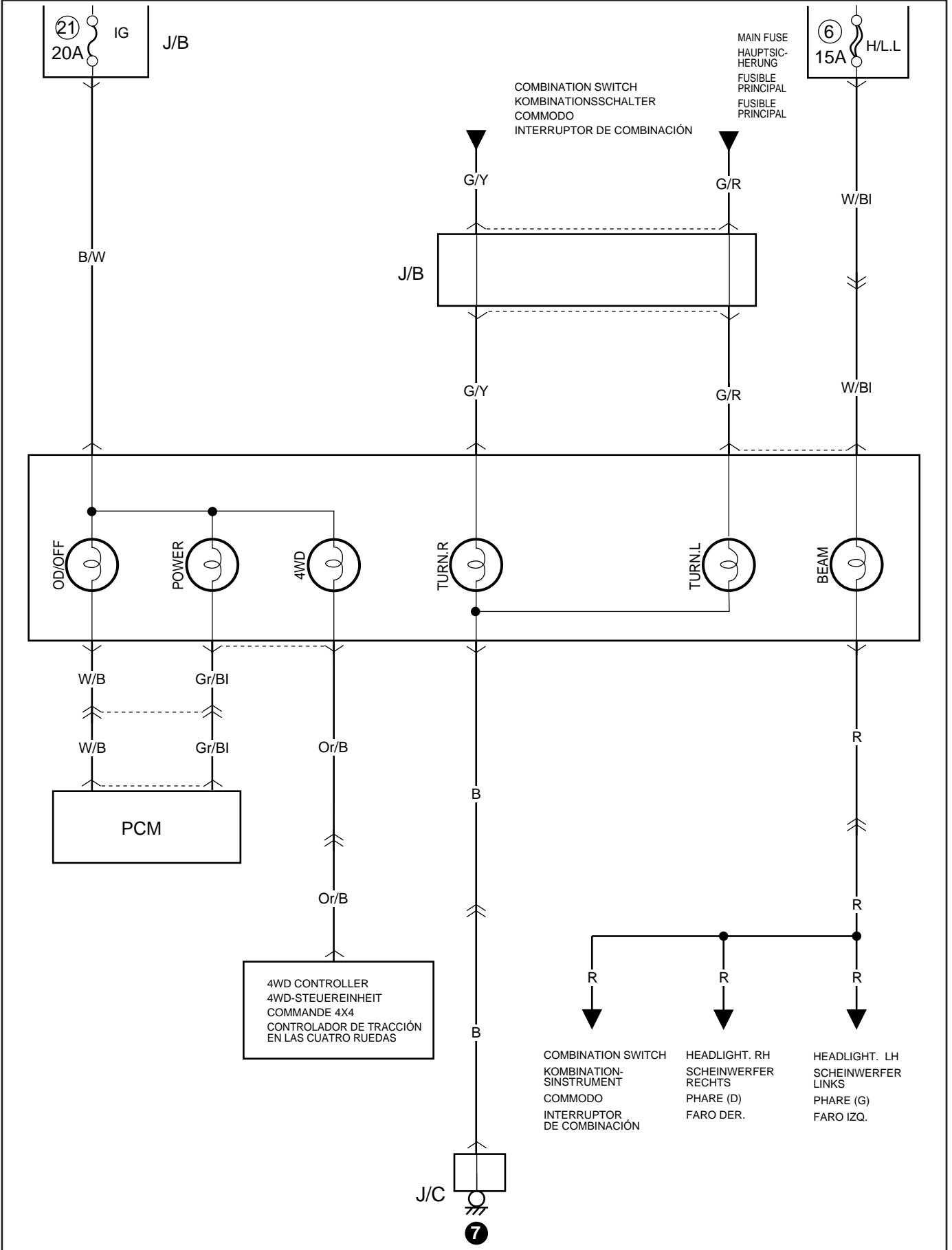

WARNING LAMP
WARNLEUCHTE
TÉMOINS D'AVERTISSEMENT
LÁMPARA DE ADVERTENCIA

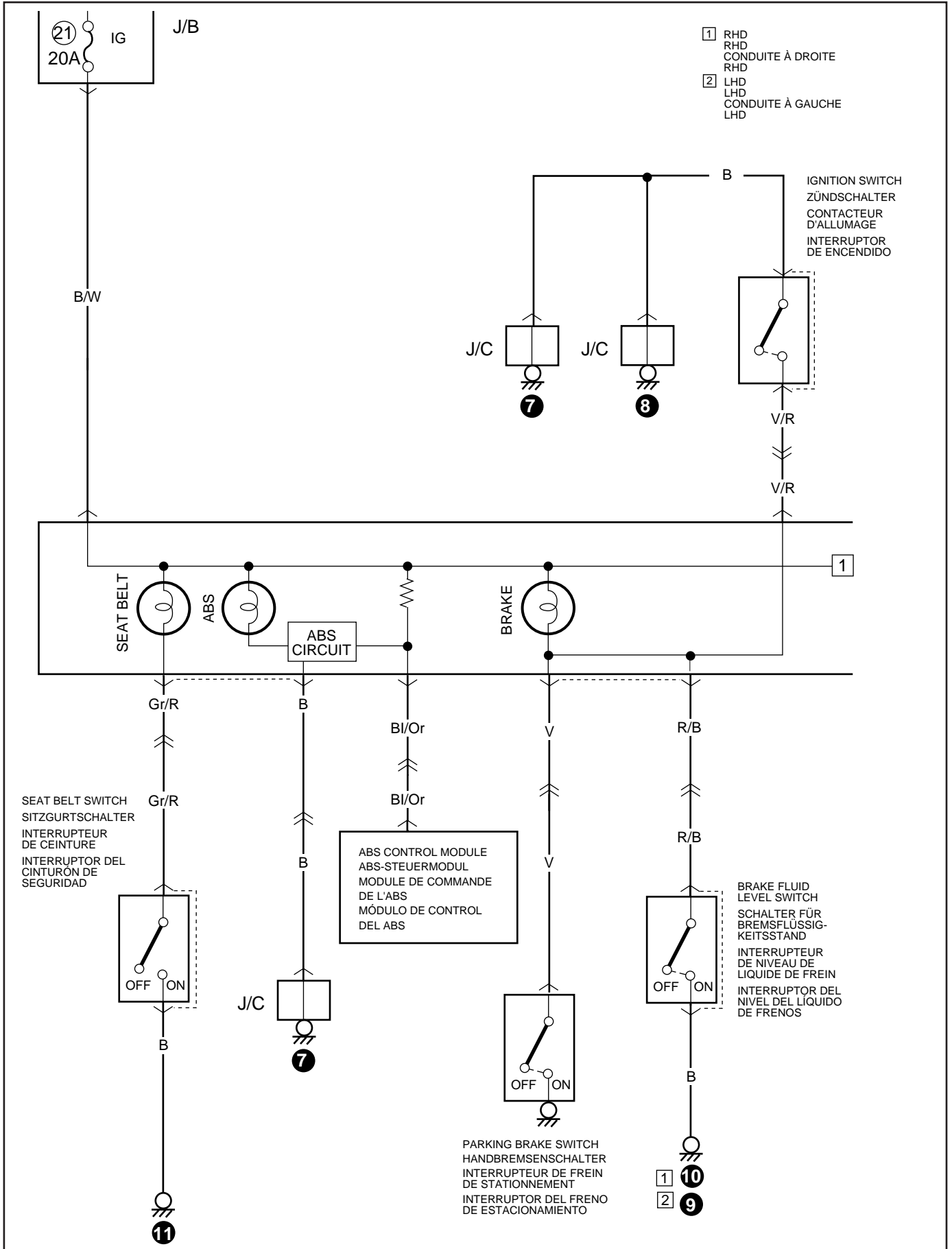

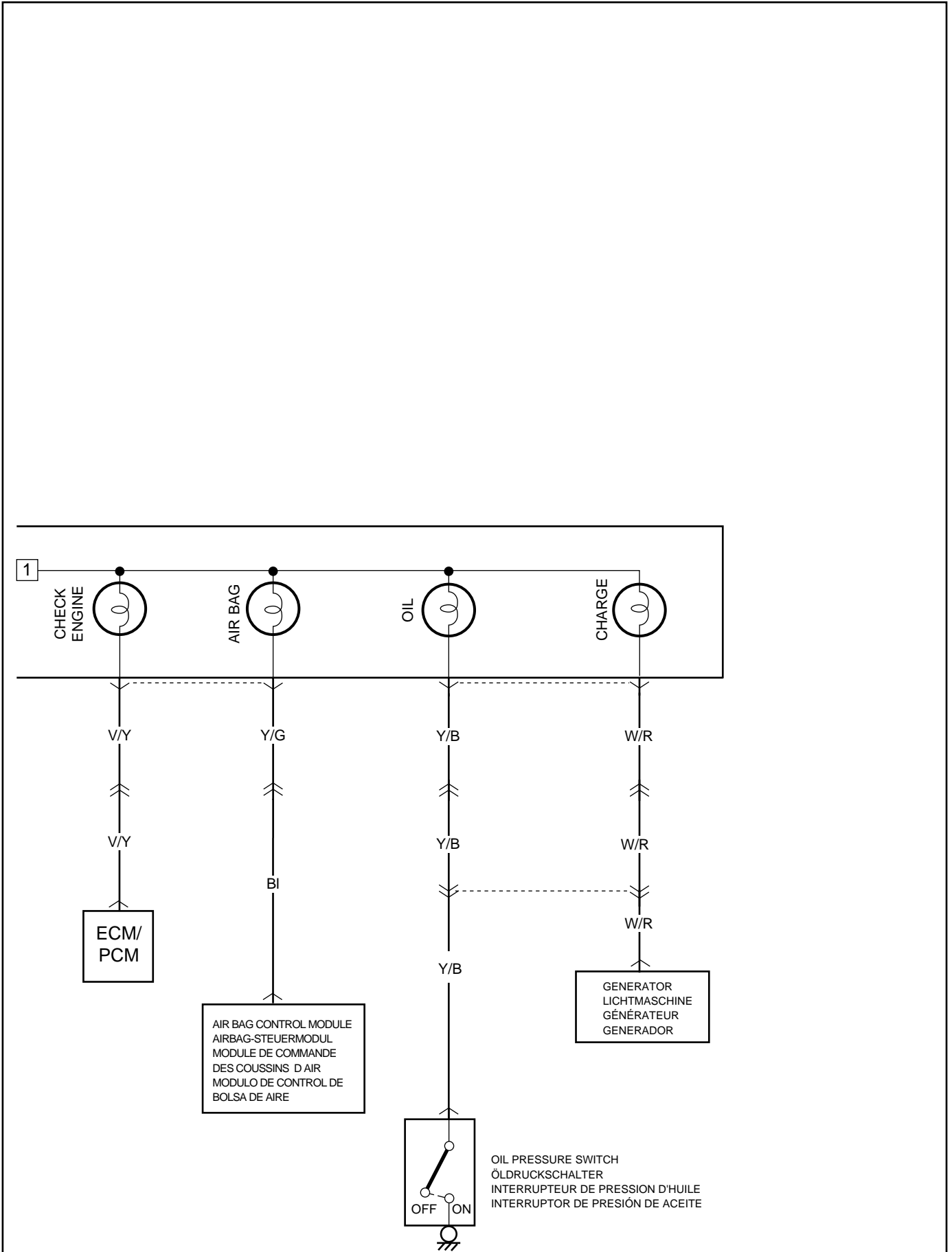

HEADLIGHT SYSTEM (VEHICLE WITHOUT DRL)
SCHEINWERFERANLAGE (FAHRZEUG OHNE DRL)
SYSTÈME DES PHARES (VÉHICULE NON ÉQUIPÉ D'UN DISPOSITIF DRL)
SISTEMA DE LOS FAROS (VEHÍCULO SIN DRL)

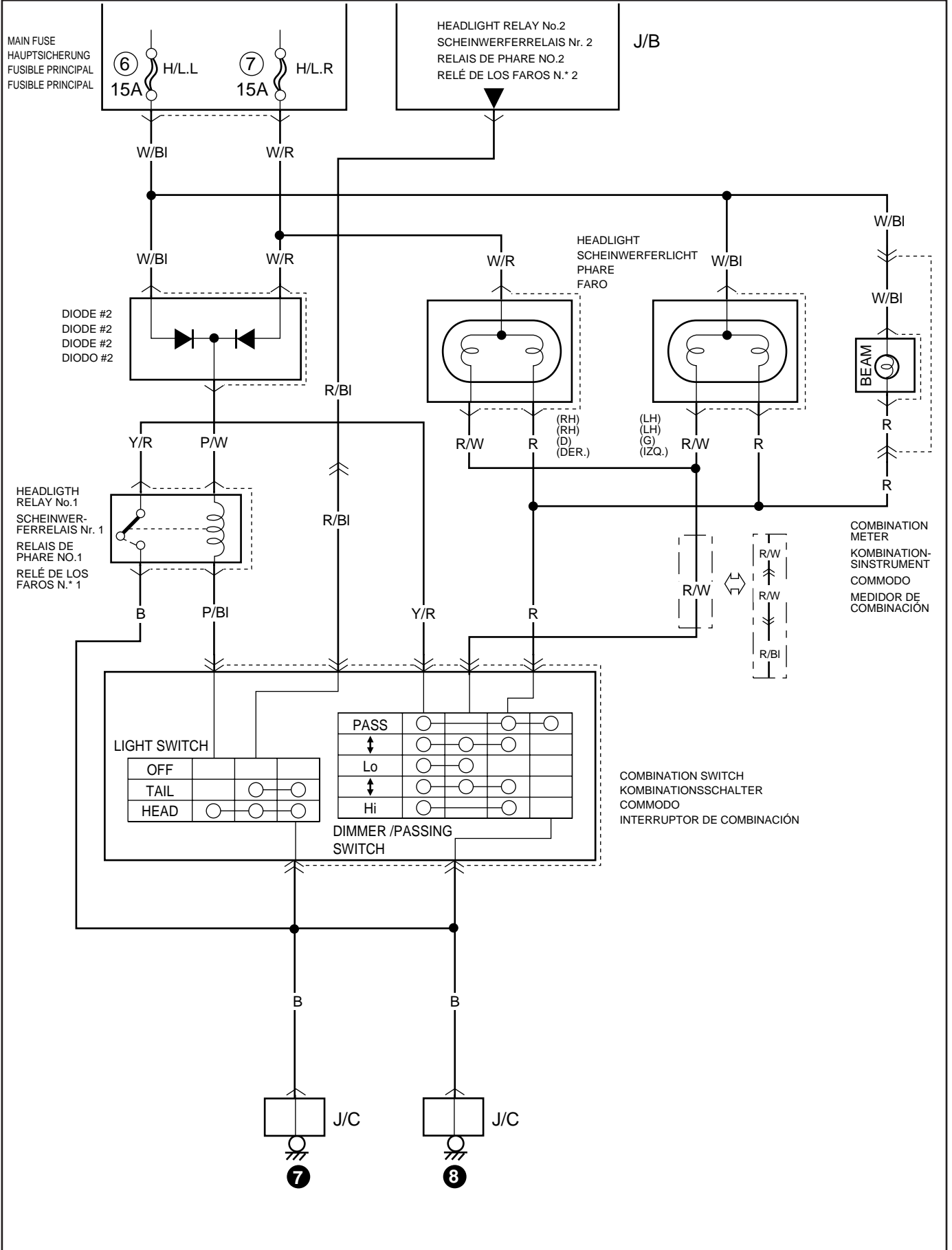

MEMO
NOTIZEN
NOTE
NOTAS

HEADLIGHT SYSTEM (VEHICLE WITH DRL)
SCHEINWERFERANLAGE (GFAHRZEUG MIT DRL)
SYSTÈME DES PHARES (VÉHICULE ÉQUIPÉ D'UN DISPOSITIF DRL)
SISTEMA DE LOS FAROS (VEHÍCULO CON DRL)

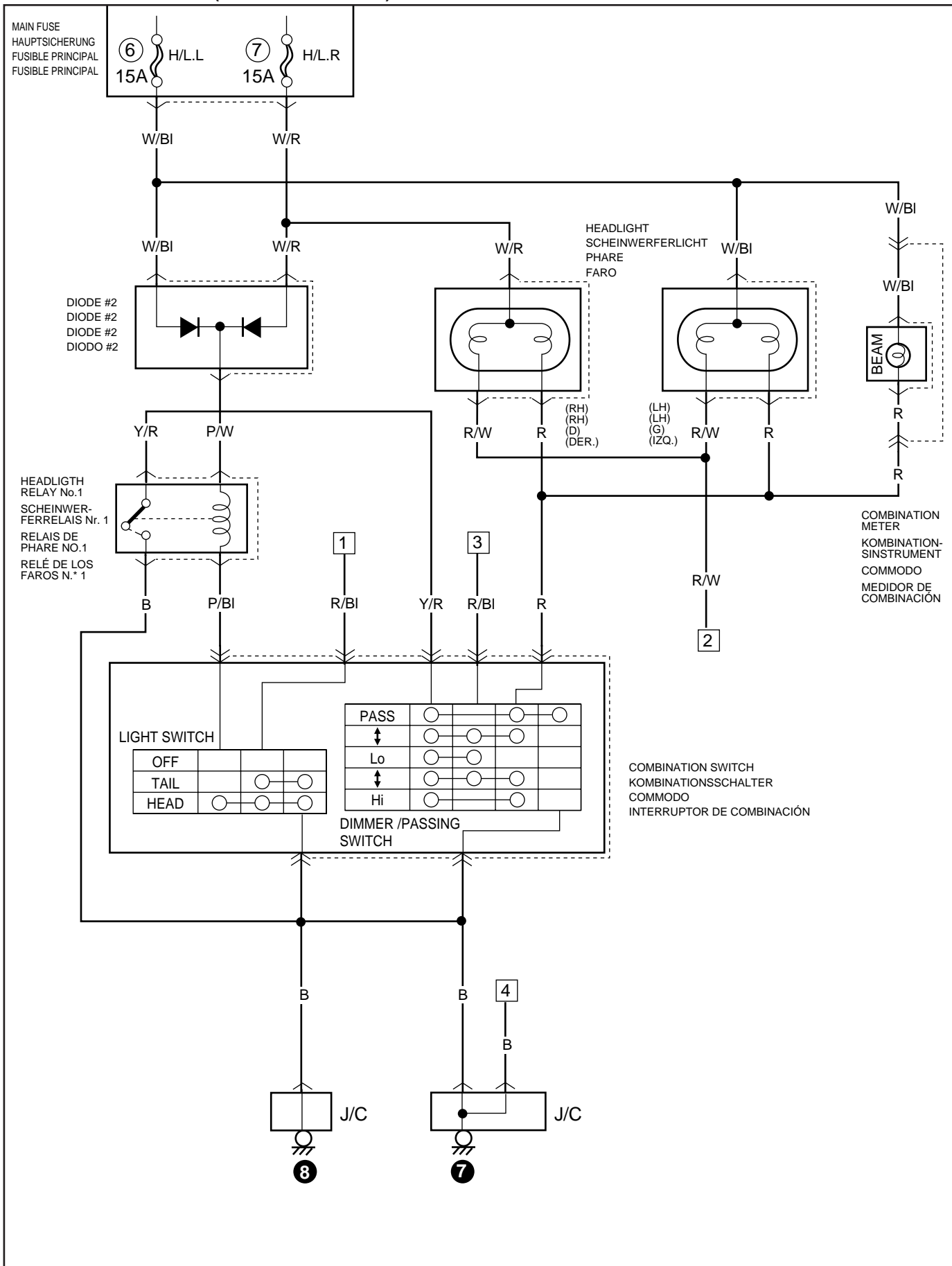

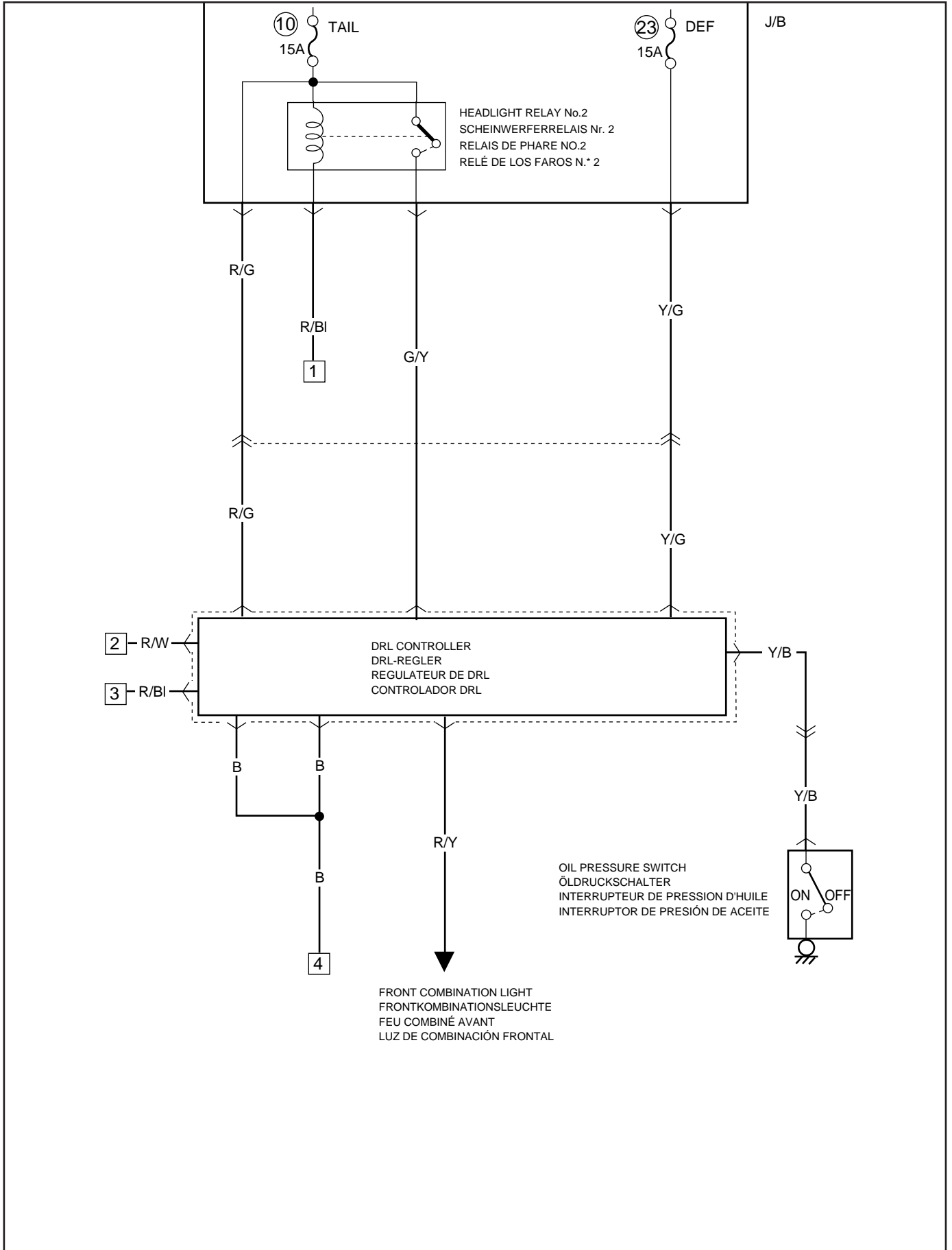

- 1 VEHICLE WITH RR FOG LIGHT
 FAHRZEUG MIT NEBELLEUCHTE RECHTS HINTEN
 VEHICULE AVEC FEU ANTIBROUILLARD ARRIERE DROIT
 LUZ ANTINEBLA DEL VEHICULO TRASERA
- 2 VEHICLE WITHOUT RR FOG LIGHT
 FAHRZEUG OHNE NEBELLEUCHTE RECHTS HINTEN
 VEHICULE SANS FEU ANTIBROUILLARD
 VEHICULO SIN LUZ ANTINEBLA TRASERA

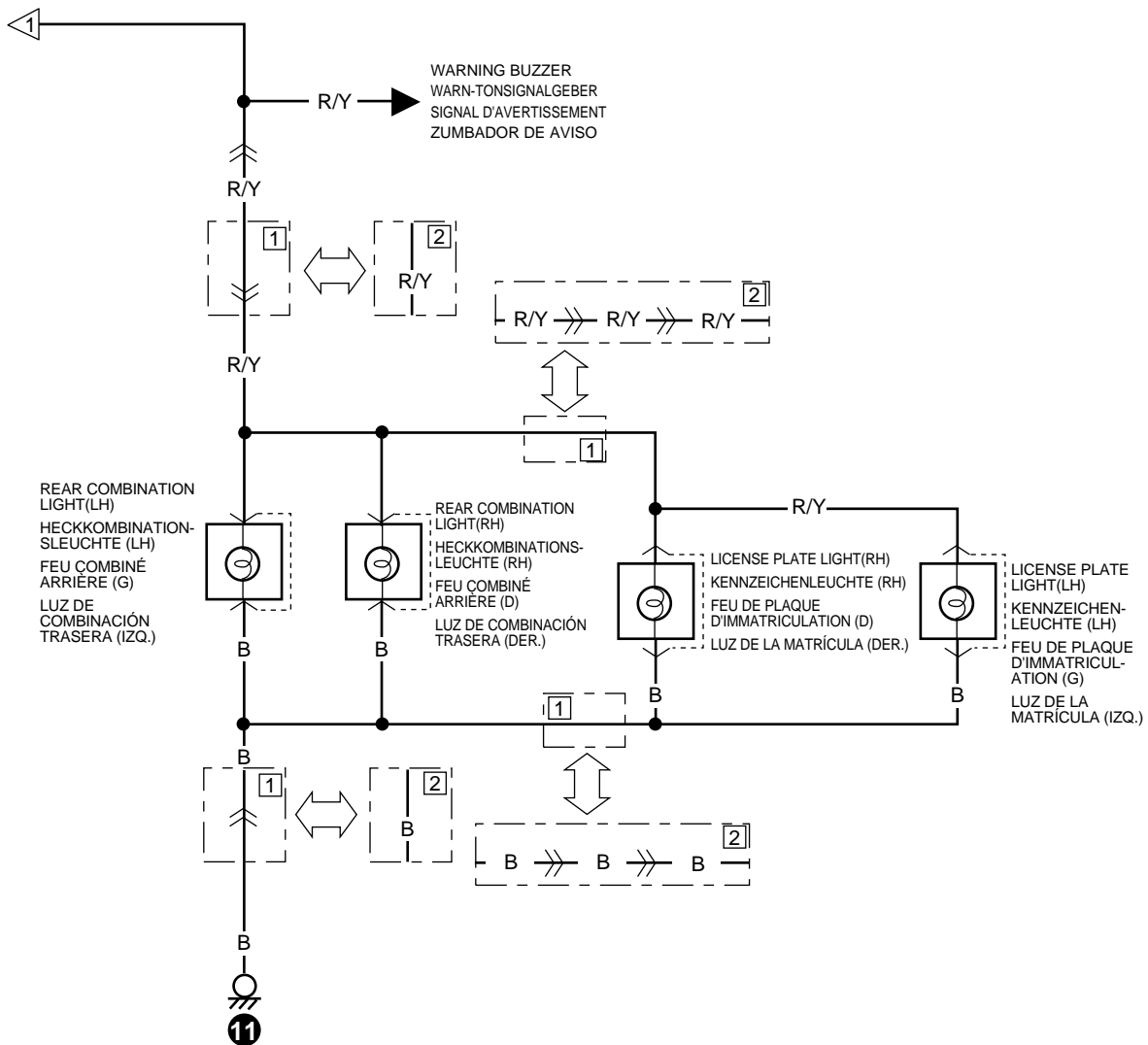

ILLUMINATION LAMP
BELEUCHTUNGSLAMPE
LAMPES TÉMOINS
LÁMPARAS DE ILUMINACIÓN

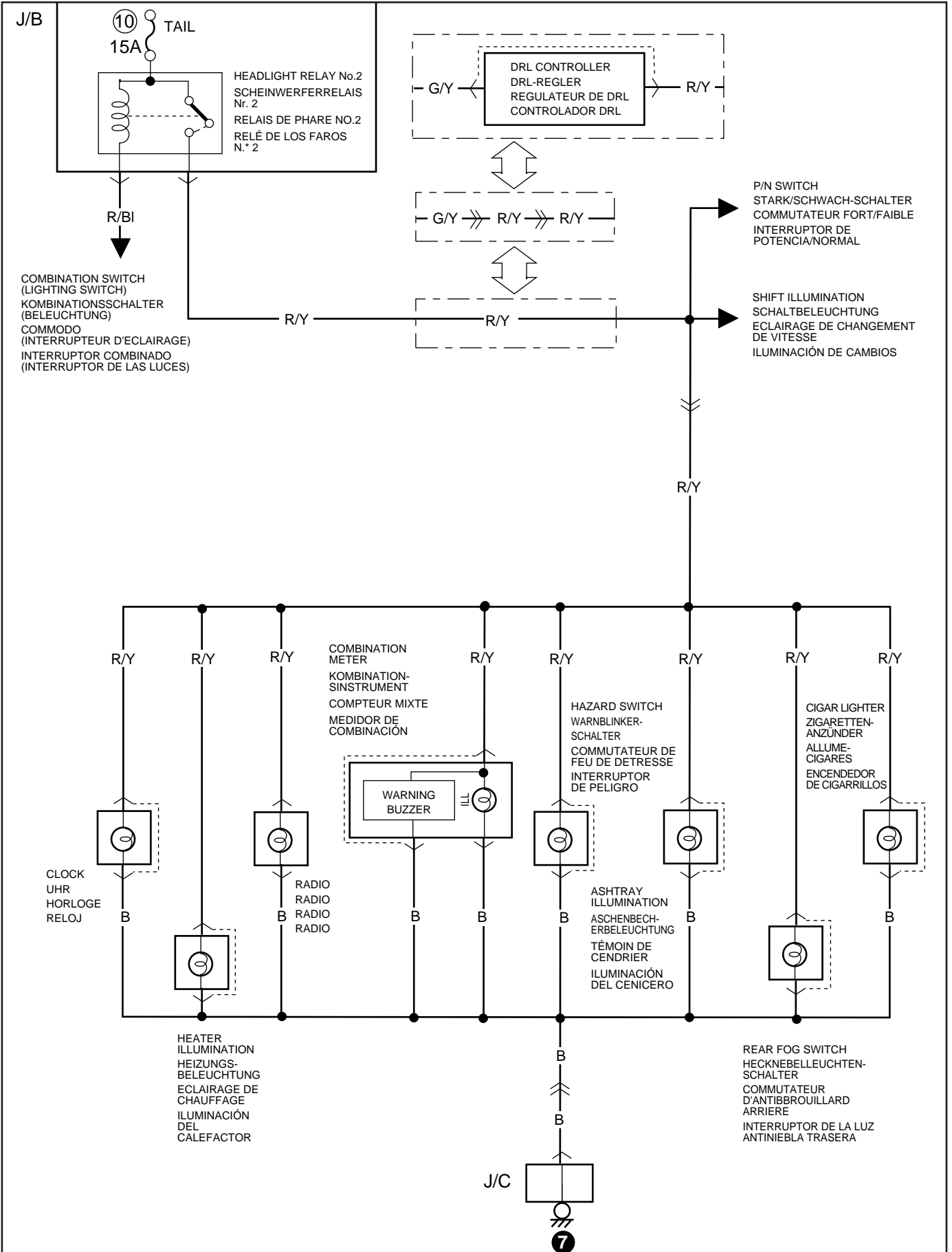

ROOM LIGHT (CANVAS TOP)
INNENRAUMBELEUCHTUNG (STOFFVERDECK)
ECLAIRAGE INTÉRIEUR (CAPOTE)
LUZ INTERIOR (TECHO DE LONA)

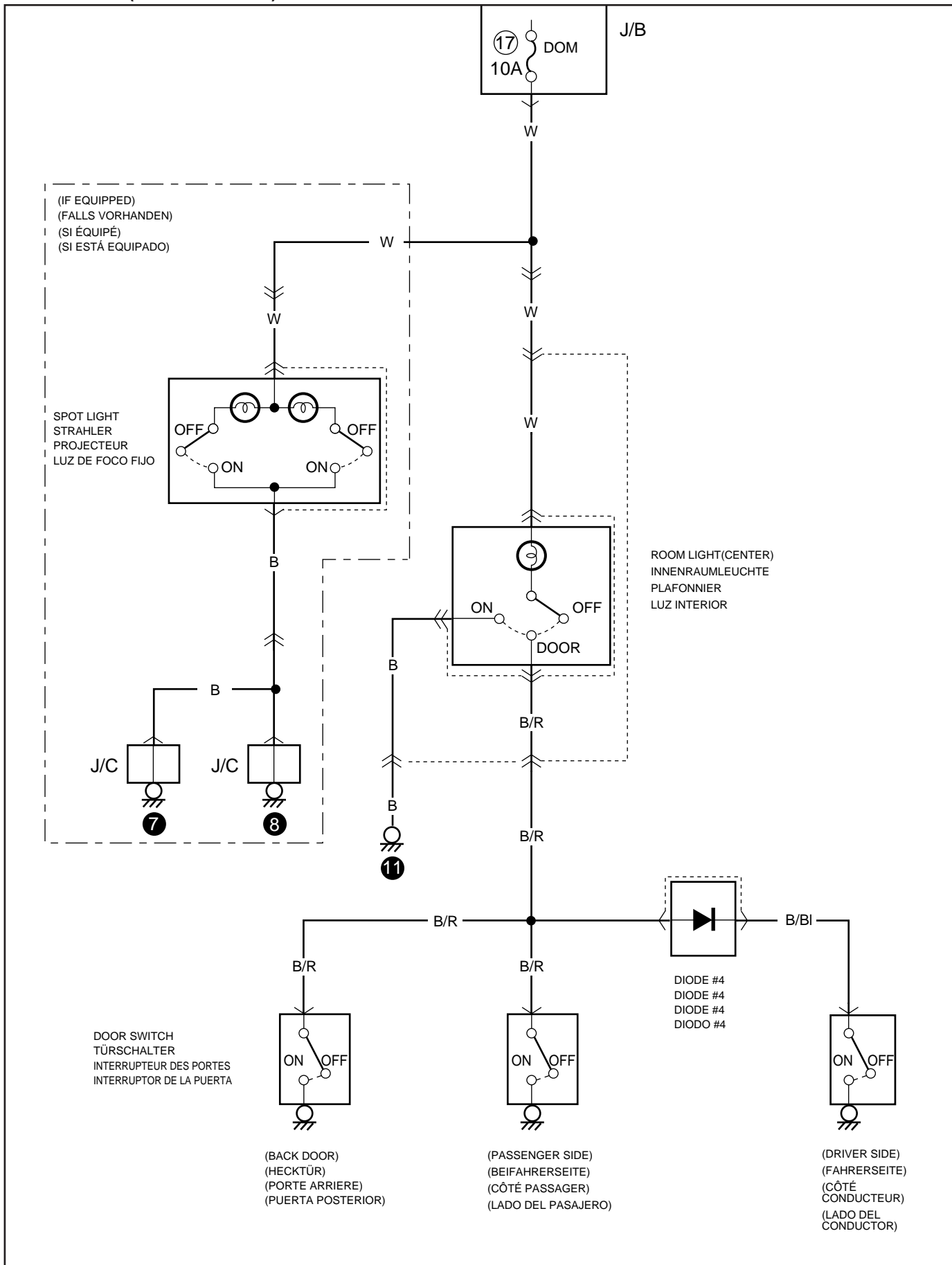

**TURN SIGNAL AND HAZARD WARNING LIGHT
 BLINKLICHT UND WARNLEUCHTE
 FEUX CLIGNOTANTS ET FEUX DE DÉTRESSE
 LUZ DE LA SEÑAL DE GIRO Y DE ADVERTENCIA DE PELIGRO**

- 1 VEHICLE WITH RR FOG LIGHT
 FAHRZEUG MIT NEBELLEUCHTE RECHTS HINTEN
 VEHICULE AVEC FEU ANTIBROUILLARD ARRIERE DROIT
 LUZ ANTINEBLA DEL VEHICULO TRASERA
- 2 VEHICLE WITHOUT RR FOG LIGHT
 FAHRZEUG OHNE NEBELLEUCHTE RECHTS HINTEN
 VEHICULE SANS FEU ANTIBROUILLARD
 VEHICULO SIN LUZ ANTINEBLA TRASERA

COMBINATION SWITCH
 KOMBINATIONSSCHALTER
 COMMODO
 INTERRUPTOR DE COMBINACIÓN

L	○	○	
LL'	○	○	
N			
RR'		○	○
R		○	○
LNR	○	○	○

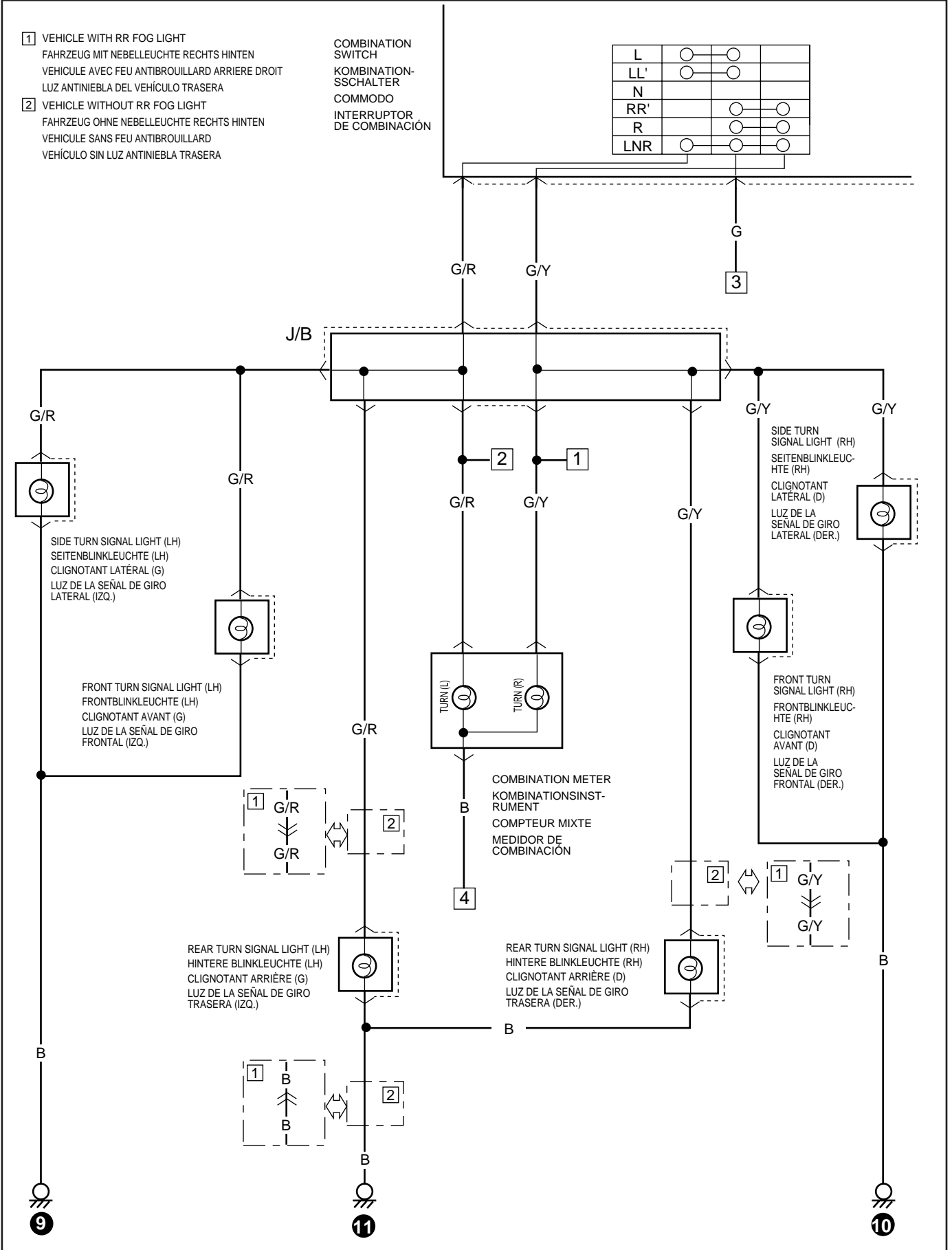

SIDE TURN SIGNAL LIGHT (LH)
 SEITENBLINKLEUCHTE (LH)
 CLIGNOTANT LATÉRAL (G)
 LUZ DE LA SEÑAL DE GIRO LATERAL (IZQ.)

FRONT TURN SIGNAL LIGHT (LH)
 FRONTBLINKLEUCHTE (LH)
 CLIGNOTANT AVANT (G)
 LUZ DE LA SEÑAL DE GIRO FRONTAL (IZQ.)

REAR TURN SIGNAL LIGHT (LH)
 HINTERE BLINKLEUCHTE (LH)
 CLIGNOTANT ARRIÈRE (G)
 LUZ DE LA SEÑAL DE GIRO TRASERA (IZQ.)

TURN (L)
 TURN (R)

COMBINATION METER
 KOMBINATIONSINSTRUMENT
 COMPTEUR MIXTE
 MEDIDOR DE COMBINACIÓN

REAR TURN SIGNAL LIGHT (RH)
 HINTERE BLINKLEUCHTE (RH)
 CLIGNOTANT ARRIÈRE (D)
 LUZ DE LA SEÑAL DE GIRO TRASERA (DER.)

SIDE TURN SIGNAL LIGHT (RH)
 SEITENBLINKLEUCHTE (RH)
 CLIGNOTANT LATÉRAL (D)
 LUZ DE LA SEÑAL DE GIRO LATERAL (DER.)

FRONT TURN SIGNAL LIGHT (RH)
 FRONTBLINKLEUCHTE (RH)
 CLIGNOTANT AVANT (D)
 LUZ DE LA SEÑAL DE GIRO FRONTAL (DER.)

10

11

9

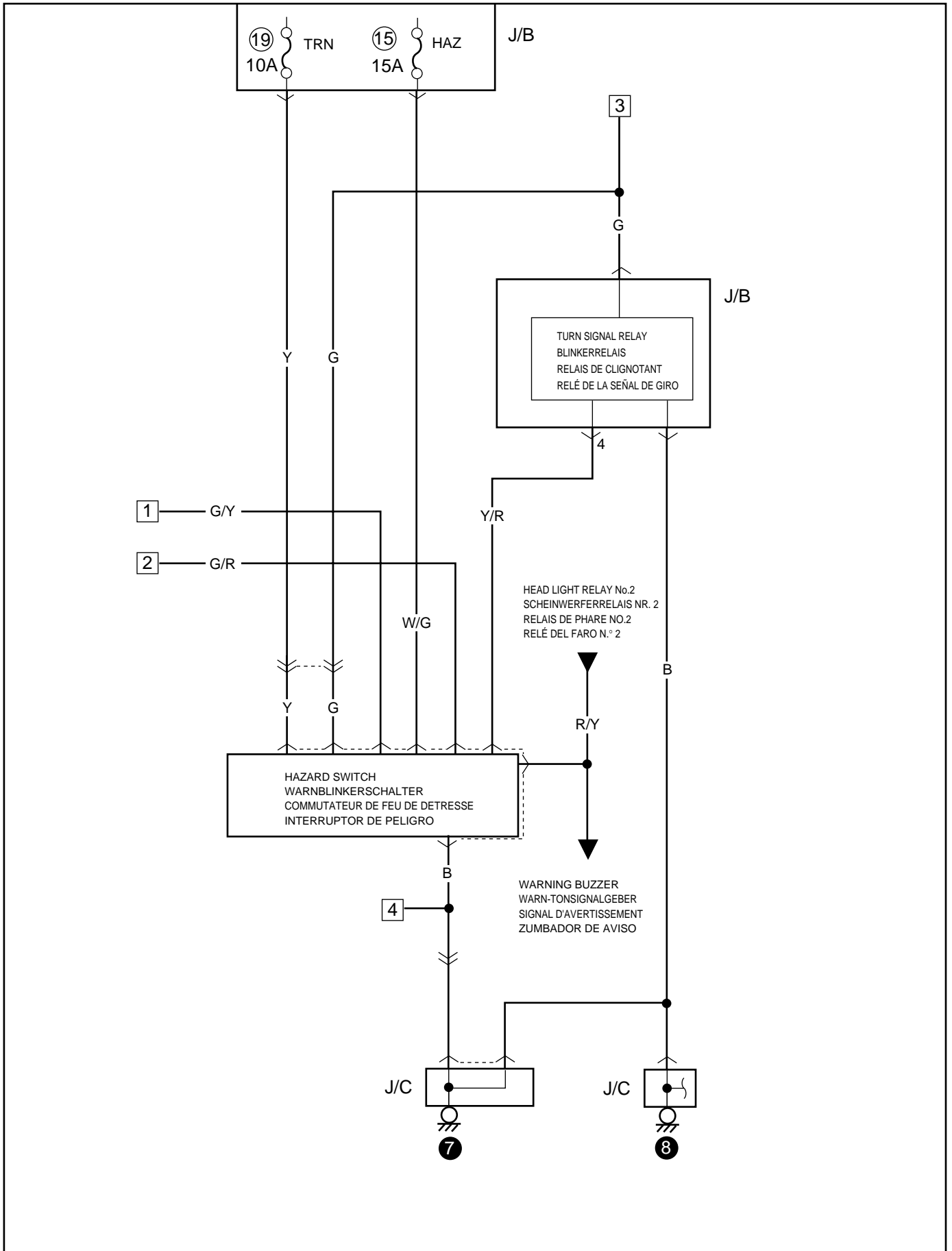

BRAKE LIGHT
BREMSLEUCHTE
FEUX STOP
LUZ DEL FRENO

- 1 AT MODELS OF NON SAUDIARABIAN SPEC AND ALL THE MT MODELS
 A/T-MODELLE (AUSSER FÜR SAUDI-ARABIEN) UND ALLE MT-MODELLE
 MODÈLES SAUF ARABIE SAOUDITE ET TOUS LES MODÈLES À BOÎTE MANUELLE
 MODELOS DE AT DE ESPEC. QUE NO SON PARA ARABIA SAUDITA Y TODOS LOS MODELOS DE MT
- 2 AT MODEL OF SAUDIARABIAN SPEC
 A/T-MODELLE FÜR SAUDI-ARABIEN
 MODÈLE ARABIE SAOUDITE
 MODELO DE AT DE ESPEC. PARA ARABIA SAUDITA
- 3 VEHICLE WITH RR FOG LIGHT
 FAHRZEUG MIT NEBELLEUCHTE RECHTS HINTEN
 VEHICULE AVEC FEU ANTIBROUILLARD ARRIERE DROIT
 LUZ ANTINEBLA DEL VEHÍCULO TRASERA
- 4 VEHICLE WITHOUT RR FOG LIGHT
 FAHRZEUG OHNE NEBELLEUCHTE RECHTS HINTEN
 VEHICULE SANS FEU ANTIBROUILLARD
 VEHÍCULO SIN LUZ ANTINEBLA TRASERA

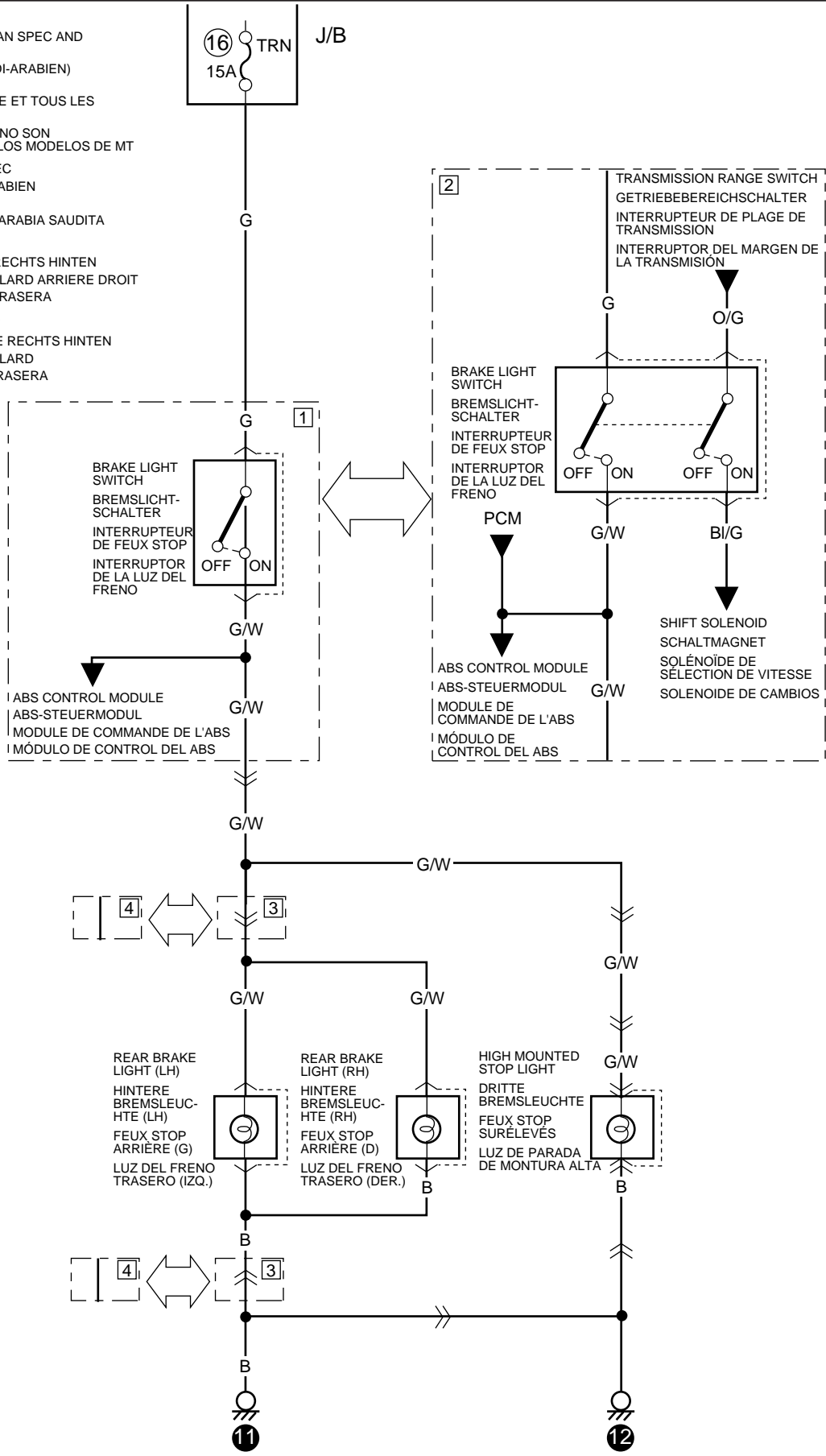

BACK-UP LAMP
RÜCKFAHRLEUCHE
FEUX DE MARCHE ARRIÈRE
LUZ DE MARCHA ATRÁS

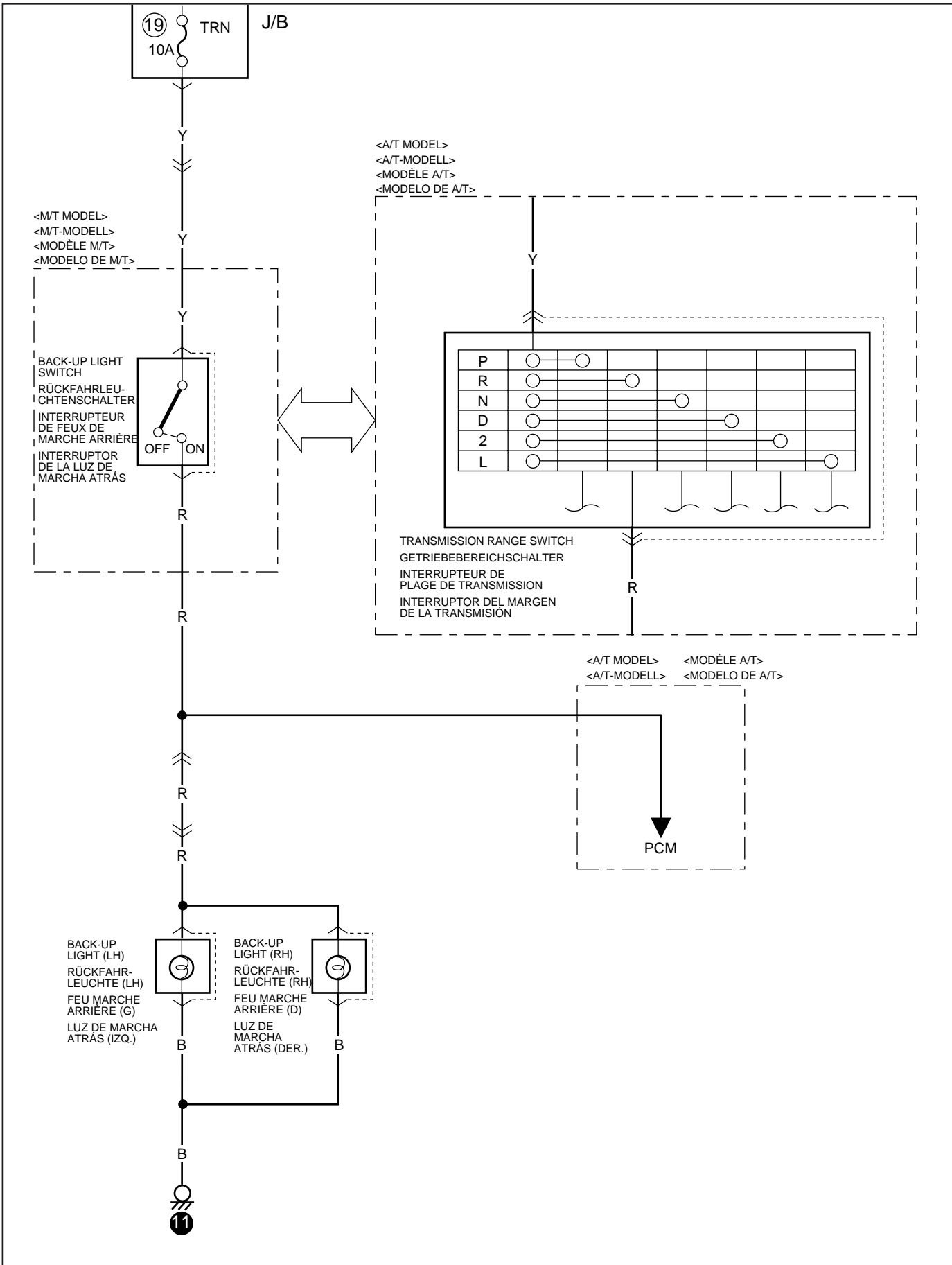

HEATER AND AIR CONDITIONING
HEIZUNG UND KLIMAAANLAGE
CHAUFFAGE ET CLIMATISATION
CALEFACTOR Y ACONDICIONADOR DE AIRE

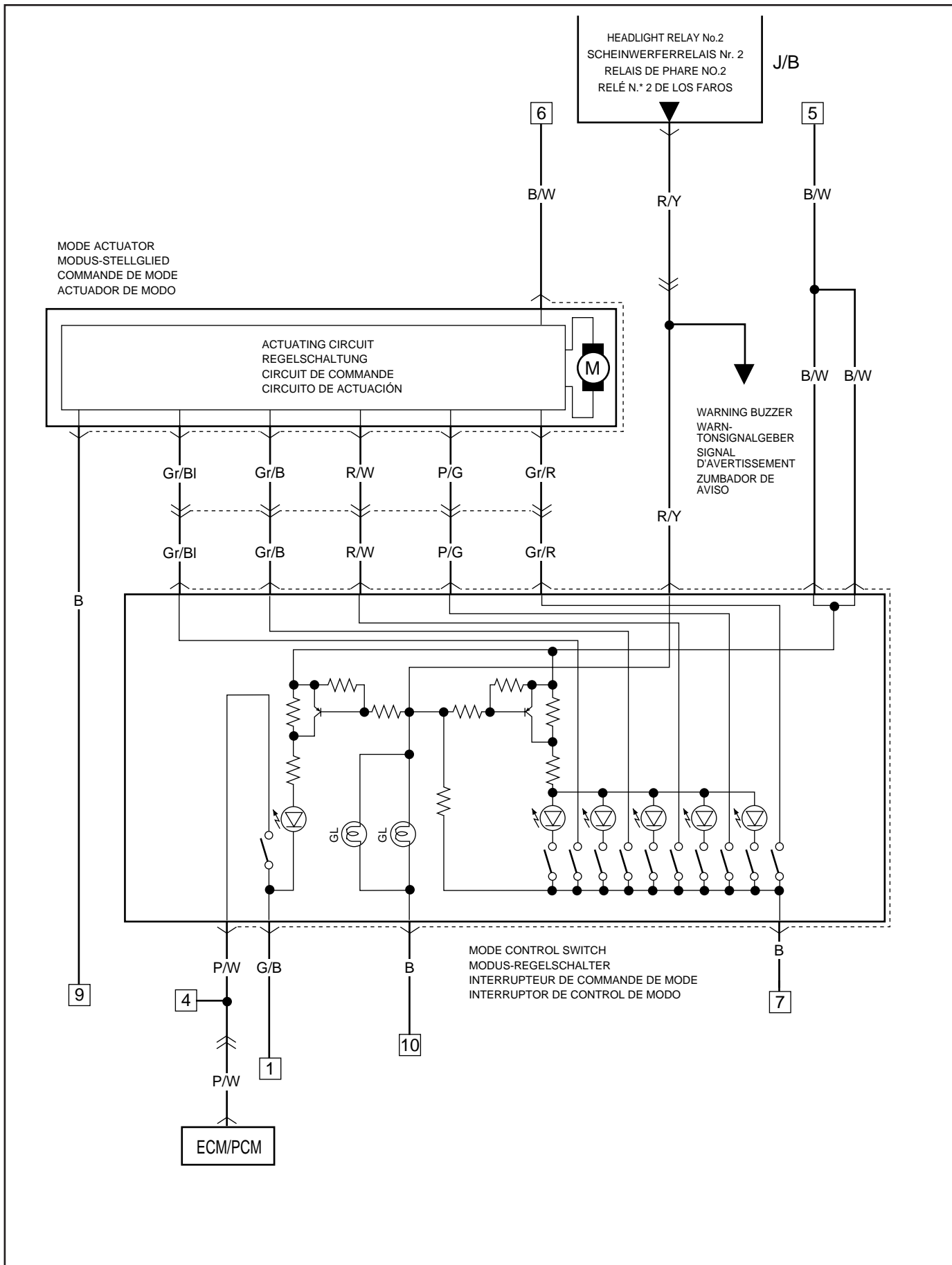

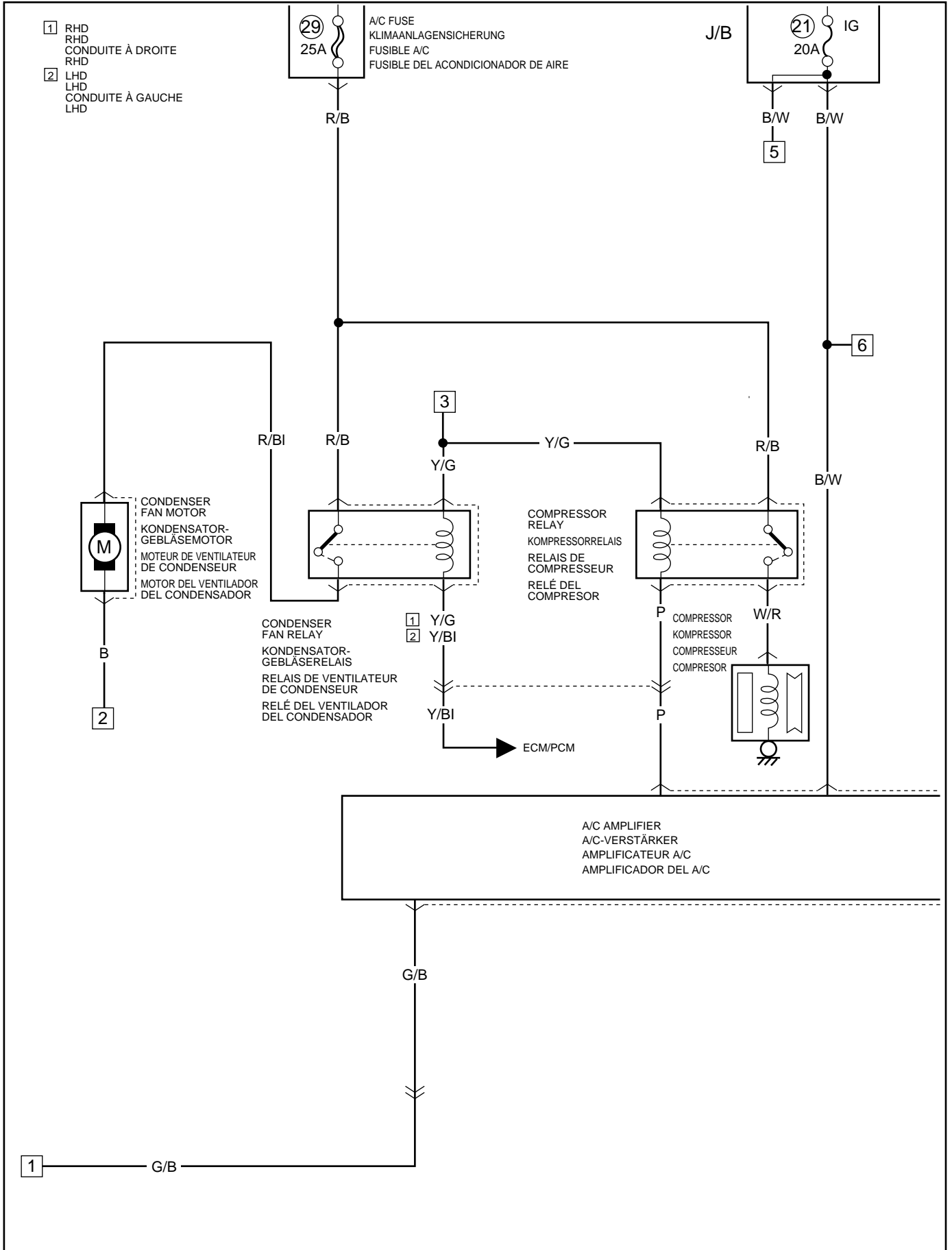

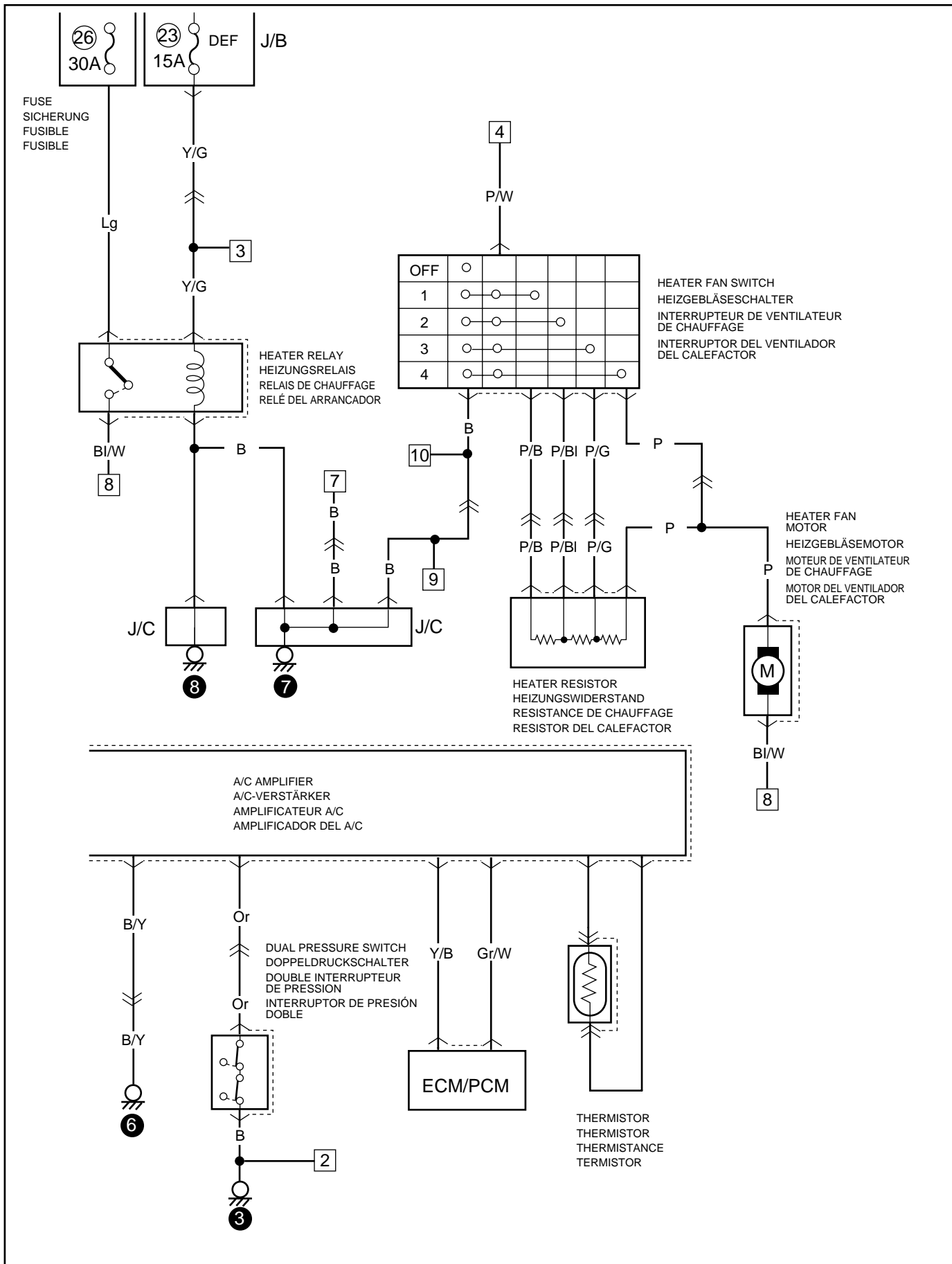

RADIO
 RADIO
 RADIO
 RADIO

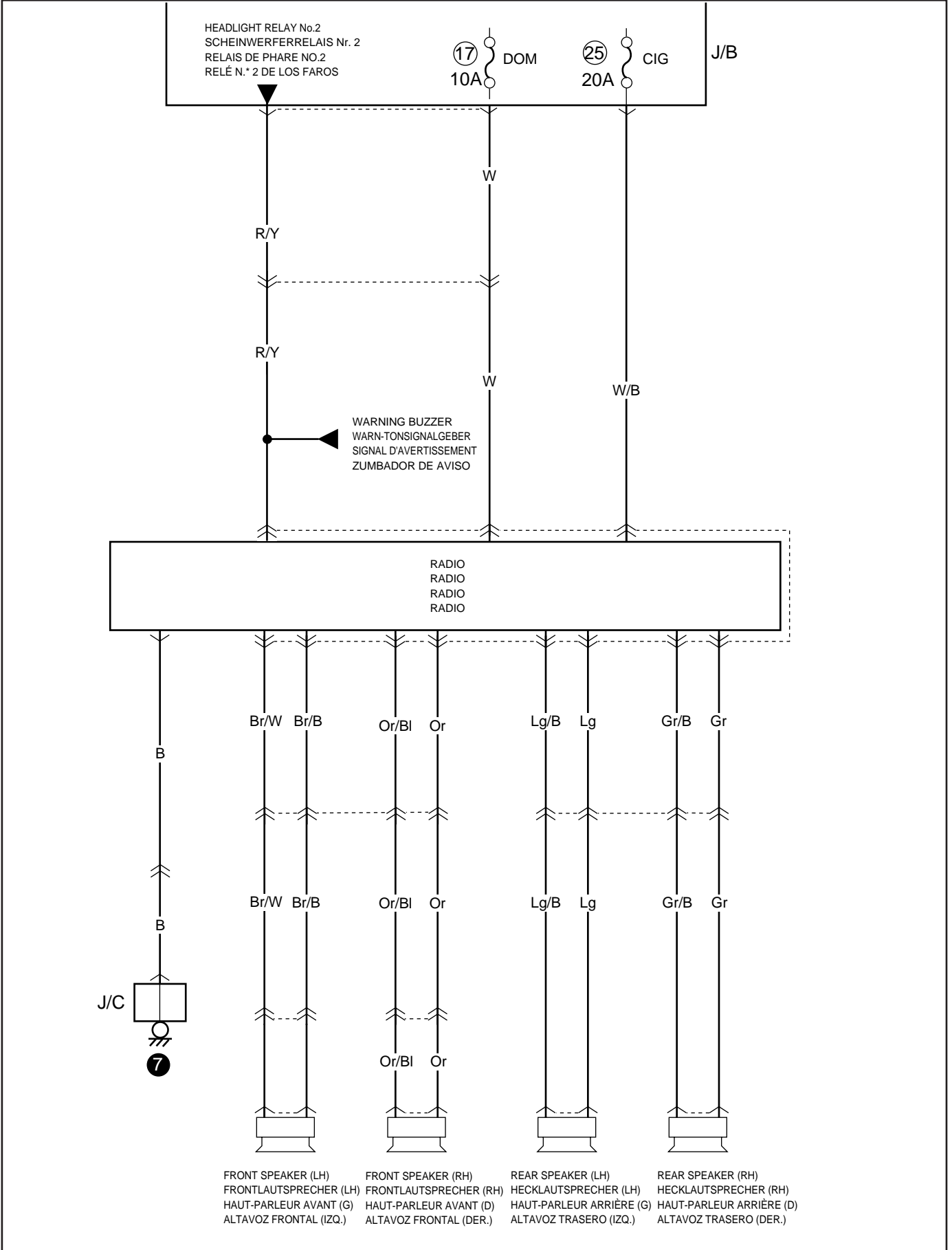

CLOCK
UHR
HORLOGE
RELOJ

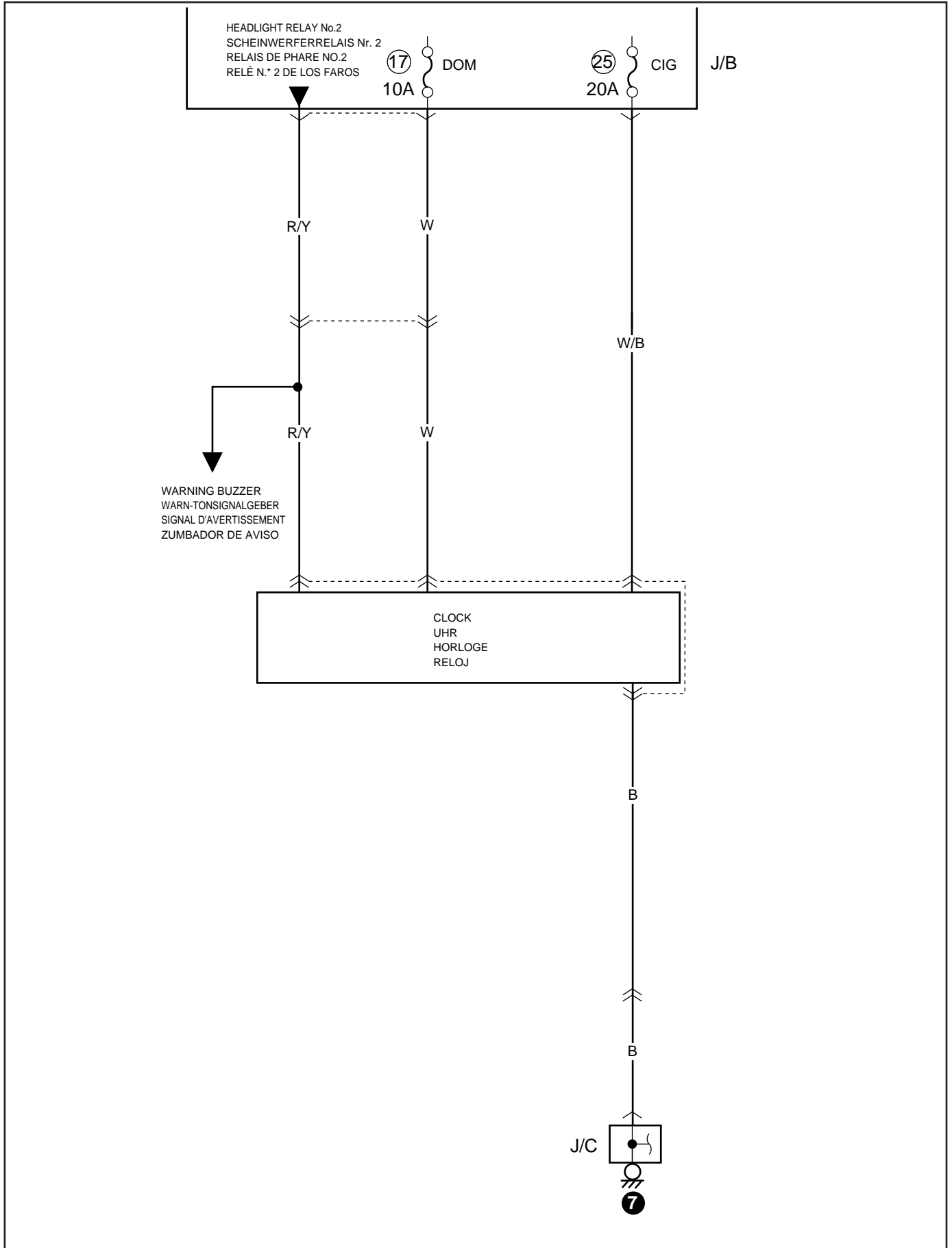

CIGAR LIGHTER
ZIGARRENANZÜNDER
ALLUME-CIGARES
ENCENDEDOR DE CIGARRILLOS

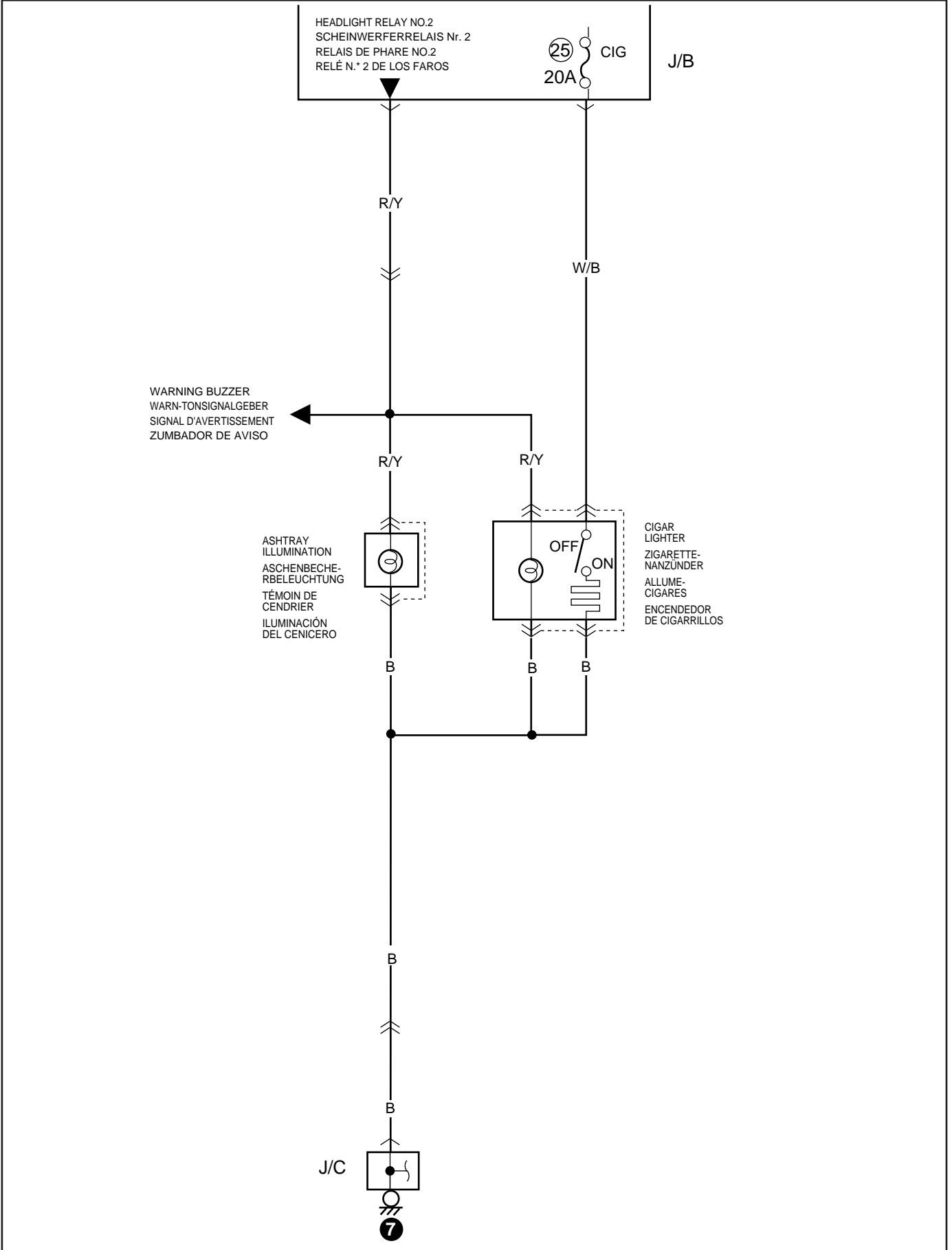

AIR-BAG CONTROL SYSTEM
AIRBAG-STEUERSYSTEM
SYSTÈME DE COMMANDE DES AIRBAGS
SISTEMA DE CONTROL DEL COLCHÓN DE AIRE

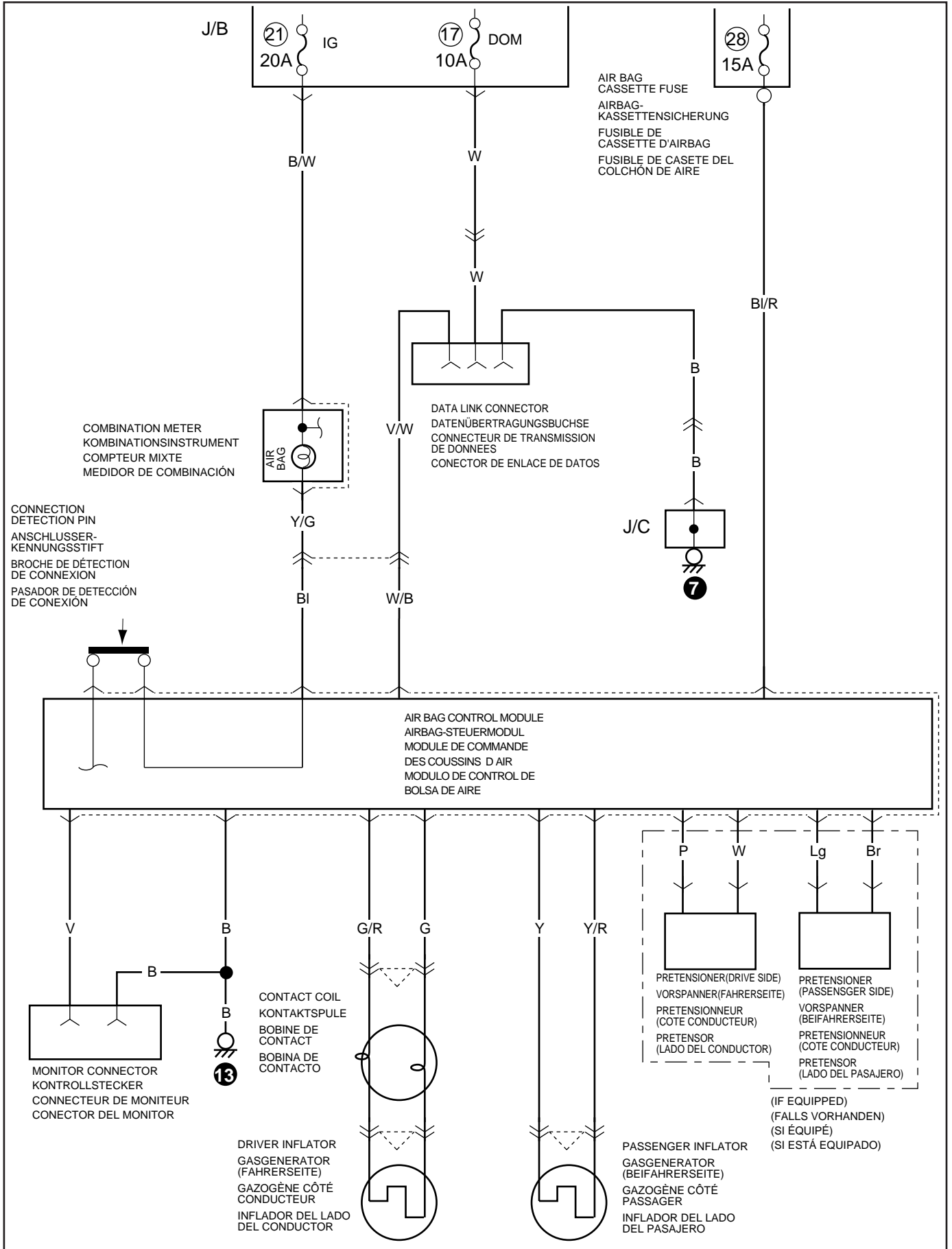

MEMO
NOTIZEN
NOTE
NOTAS

ANTI-LOCK BRAKE SYSTEM
ANTIBLOCKIERSYSTEM
SYSTÈME D'ANTIBLOPAGE DES FREINS
SISTEMA DE FRENOS ANTIENCLAVAMIENTO

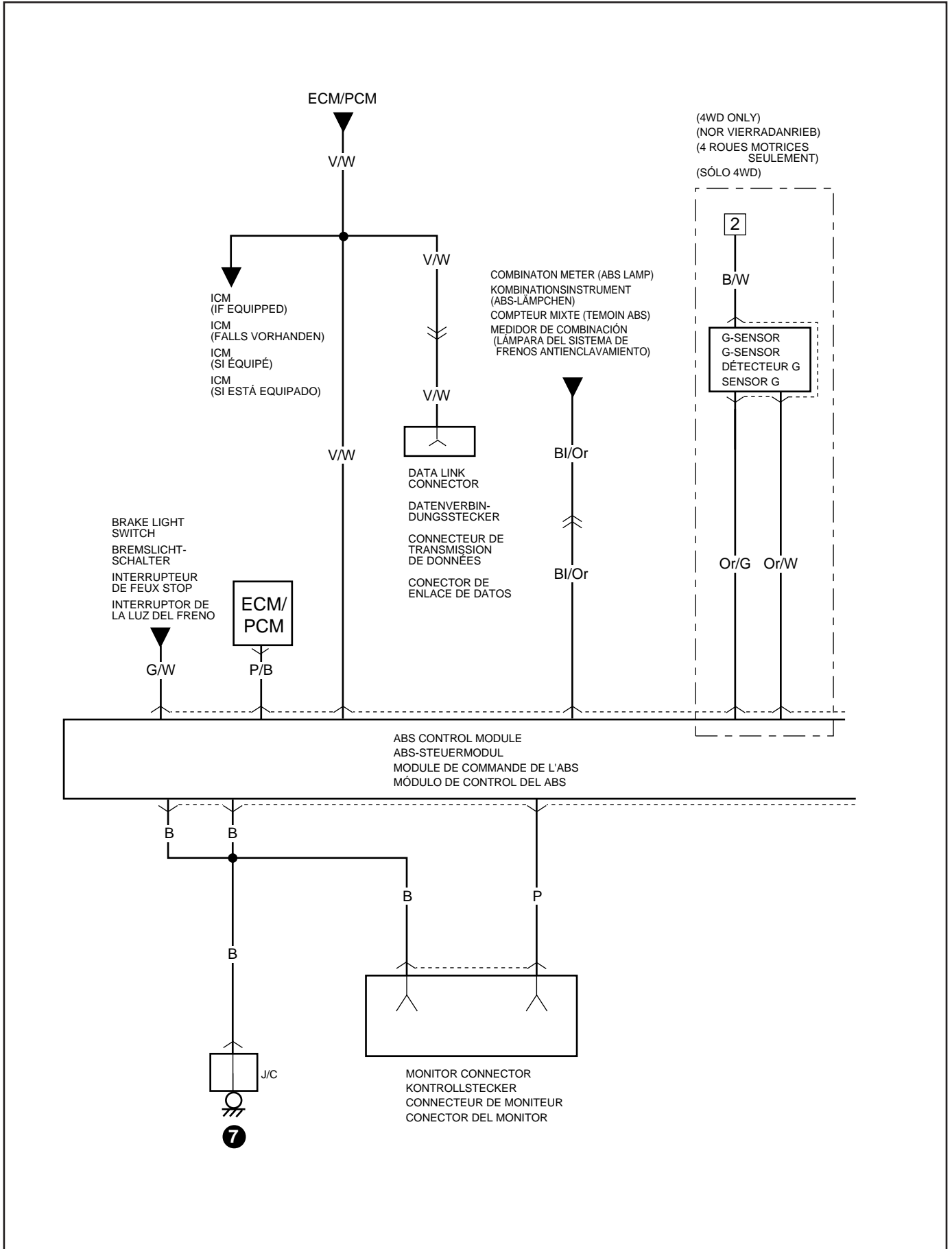

REAR FOG LIGHT
HECKNEBELLEUCHTE
ANTIBROUILLARD ARRIÈRE
LUZ ANTINEBLA TRASERA

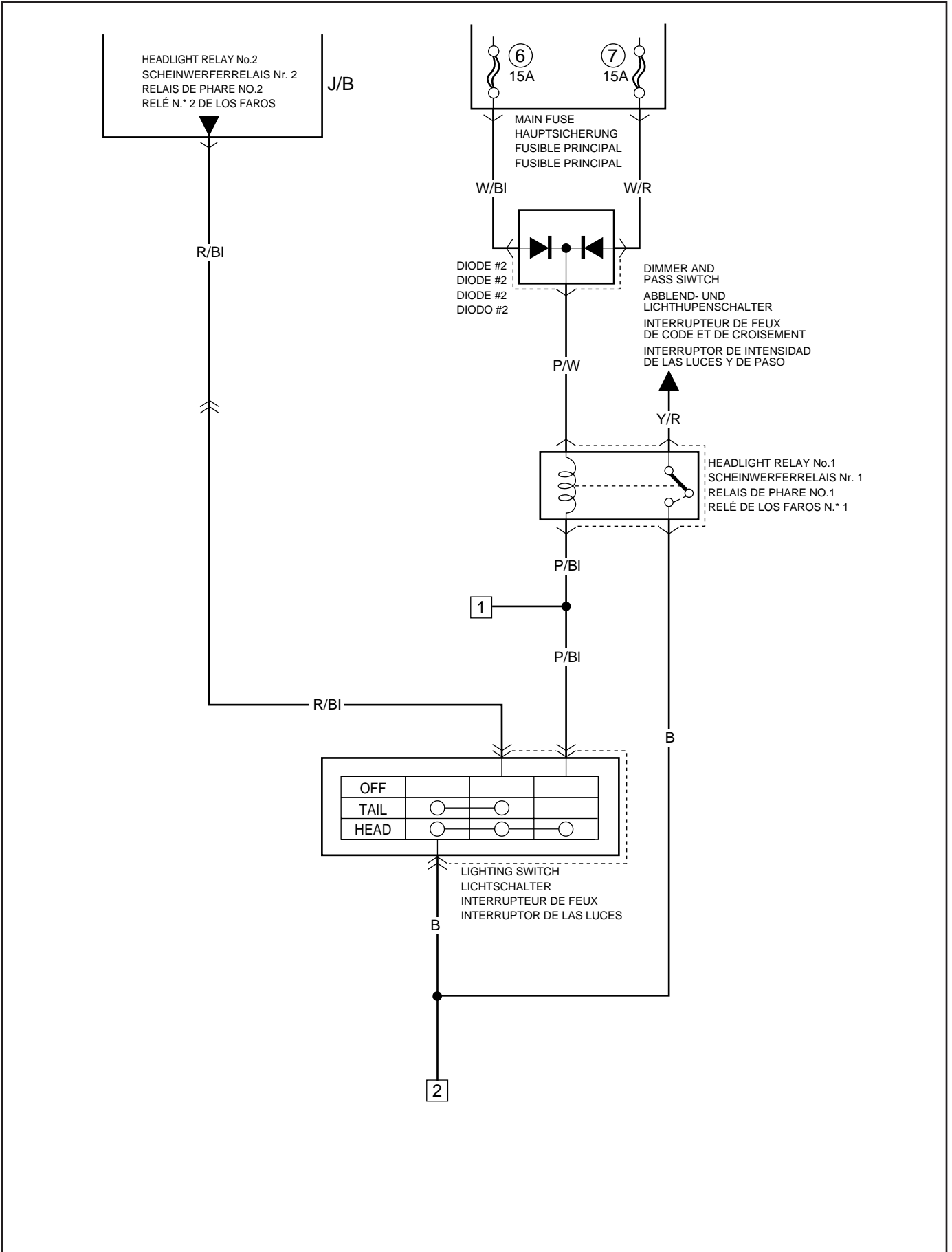

HEADLIGHT BEAM LEVELING SYSTEM
SCHEINWERFERSTRAHL-NIVELLIERSYSTEM
SYSTÈME DE RÉGLAGE DES FAISCEAUX DE PHARES
SISTEMA DE NIVELACIÓN DEL HAZ DE LUZ DE LOS FAROS

